

HEAT PUMP B1 SERIES



After more than 32 years of international experience in water technology with particular expertise in swimming pool pumps and filters, Emaux has evolved into a major force spanning 5 continents and appointing more than 200 distributors worldwide. Our research facilities and state of the art manufacturing plant ensures quality products that are specified where reliable and efficient filtration is critical. After considerable research into the Australian market - Emaux Water Technology Australia was launched in 2008 with headquarters in Perth. Following Emaux principles – all Emaux products were tested to meet Australian Standard AS/NZS 60335.1 and distribution and servicing established in all key centres.



EMAUX
Pool Pumps and Filters

The clear choice in water technology

Emaux Water Technology (Australia) Pty Ltd 12 Kembla Way Willetton WA 6155 Australia t:1300 293 633 e:info@emaux.com.au w: www.emaux.com.au

B1 SERIES

Performance and features

- High efficiency, with a COP value of up to 5.0 our heat pumps are highly efficient when transferring heat from the air to the swimming pool water. You can save as much as 80% of cost in comparison to an electrical heater.
- The heat exchanger is made of PVC & Titanium tube, for maximum longevity when exposed to swimming pool water.
- Easy control and operation. Simply switch it on and set the desired pool water temperature.
- The system includes a micro-computer controller, allowing all operation parameters to be pre-set. Operation status is displayed on the controller with an LCD display.



Model No		HP14B1	HP17B1	HP21B1	HP26B1
Code		88360508	88360509	88360610	88360611
Rated Heating Capacity	W	14000	17000	21000	26000
	BTU	48000	60000	72000	90000
Heating Input Power	W	2880	3500	4350	5300
Heating Running Current	A	13.3	16.2	7.8	8.9
Rated Cooling Capacity	W	8600	10200	13500	16000
	BTU	29500	35000	46000	55000
Cooling Input Power	W	3080	3650	4820	5300
Cooling Running Current	A	14.3	16.8	8.2	9.5
Power Supply	V/PH/HZ	220V/1PH/50HZ		380V/3PH/50HZ	
Controller	•	Electronic Controller			
Quantity of Compressor	•	1	1	1	1
Compressor	•	Rotary	Scroll		
Quantity of Fan	•	1	1	2	2
Input power of Fan	W	60	90	90*2	90*2
Fan Speed	RPM	950	890	890	890
Noise	Db(A)	60	60	60	60
Water Connection	mm	1.5"	1.5"	1.5"	1.5"
Water Flow Volume	m ³ /h	5-8	5-8	6-10	6-10
Water Pressure Drop	kpa	15	16	16	16
Net Dimension	L	1110	1110	1110	1110
	W	470	470	470	470
	H	680	930	1240	1240
Packing Dimension	L	1165	1165	1165	1165
	W	485	485	485	485
	H	780	1030	1340	1340
Weight	Net Weight	99	115	138	139
	Gross Weight	104	120	143	144

HP14B1 & HP17B1

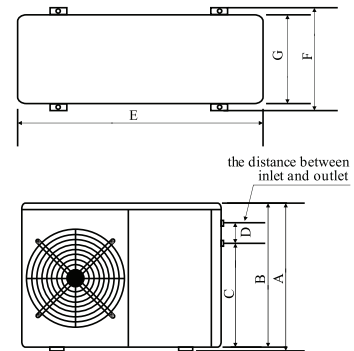

HP21B1 & HP26B1

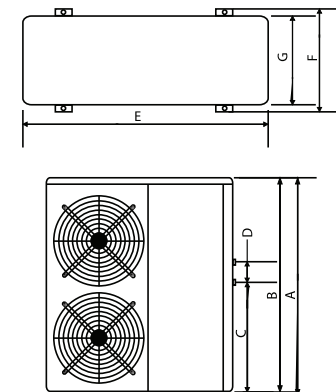

Measuring Conditions

Heating : Dry bulb 24°C, Wet Bulb 19°C, Water entering temperature 27°C

Cooling : Dry bulb 35°C, Wet Bulb 24°C, Water entering temperature 27°C

Model	Dimensions (mm)						
	A	B	C	D	E	G	F
HP14B1	680	667	400	115	1110	470	420
HP17B1	930	915	650	115	1110	470	420
HP21B1	1240	1220	650	115	1110	470	420
HP26B1	1240	1220	650	115	1110	470	420