

INFRARED MOTION CEILING MOUNT SENSOR



Welcome to use Infrared motion sensor!

The product is a new saving-energy switch; it adopts good sensitivity detector, integrated circuit. It gathers automatism, convenience, safety, saving-energy and practicality functions. The wide detection field is consisting of detectors. It works by receiving human motion infrared rays. When one enters the detection field, it can start the load at once and identify automatically day and night; its installation is very convenient and its using is very wide. It has functions of power indication and the detection indication.

SPECIFICATION

Power Frequency	50 Hz	Power Consumption	0.45W (Work) 0.1W (Static)
Working Temp.	-20~+40°C	Detection Motion Speed	0.6~1.5m/s
Ambient Light	3-2000 LUX (adjustable)	Detection Distance	6m max (24°C)
Time-delay	Min. 10sec±3sec Max. 8min±2min	Detection Range	360°
Installation Height	2.2m~4m	Working Humidity	<93% RH
Rated Load	1200W - Incandescent 300W - Energy Saving	Power Source	220-240 V/AC

FUNCTION

- Can identify day and night: The consumer can adjust work ambient light. It can work in the daytime and at night when it is adjusted on the “sun” position (max). It can work in the ambient light less than 3LUX when it is adjusted on the “moon” position (min). As for the adjustment pattern, please refer to the testing pattern.
- Time-Delay is added continually: When it receives the second induction signals after the first induction, it will compute time once more on the basic of the first time-delay rest.
- Time-Delay is adjustable. It can be set according to the consumer’s desire. The minimum time is 10sec±3sec. The maximum is 8min±2min.

INSTALLATION (See The Diagram)

- Switch off the power.
- Turn clockwise the bottom-stand and take off it. The power wire cross the hole in the middle of bottom-stand.
- The bottom-stand is fixed on the selected position with inflated screw.
- Connect the power and the load into the connection-wire column of the sensor according to connection-wire diagram.
- The sensor aimed at the mouth of bottom-stand and turned anti-clockwise.

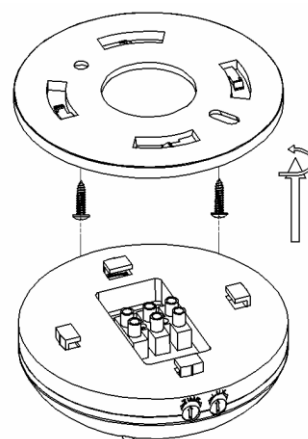

CONNECT-WIRE FIGURE

(See the right figure)

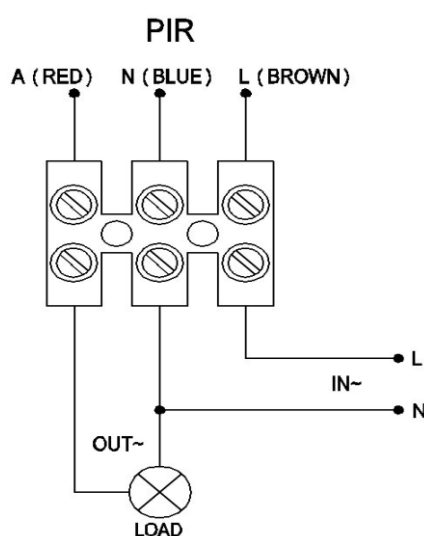

TEST

- Turn the TIME knob to minimum (-) position with anti-clockwise. Turn the LUX knob to SUN position with anti-clockwise.
- Switch on the power, the controlled load and indication lamp both are not working. Preheat 30 sec later, the load and indication lamp should be turned on synchronization. In the absence of no inductor signals, the load should be stopped working within 5-30sec, the indicator lamp is turned off.
- After the first sense is finished, and it will sense again after 5~10sec. The load should work. When there is no inductor signals in the indicator lamp, the load should be stopped working within 5-15sec.
- Turn LUX knob clockwise on the minimum (MOON position). If it is adjusted in the less than 3LUX, the inductor load should not work after load stop working. If you cover the detection window with the opaque objects (towel etc), the load work. under no induction signal condition, the load should stop working within 5-15sec.

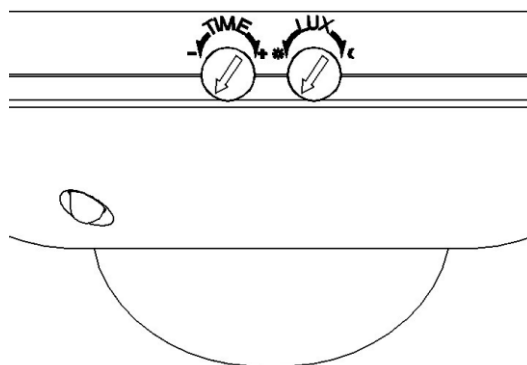

Note: when testing in daylight, please turn LUX knob to ☀ (SUN) position, otherwise the sensor lamp could not work!

NOTE

- Electrician or experienced human can install it.
- The unrest objects can't be regarded the installation basis-face.
- In front of the detection window there aren't hinder or unrest objects effecting detection.
- Avoid installing it near air temperature alteration zones for example: air condition, central heating, etc.
- Please don't open the case for your safety if you find the hitch after installation.
- If there are some difference between instruction and the function the product has, please give priority to product and sorry not to inform you additionally.

SOME PROBLEM AND SOLVED WAY

- The load don't work:
 - a. Check the power and the load.
 - b. Whether the indicator light is turned on after sensing? If yes, please check load.
 - c. If the indicator light does not turn on after sensing, please check if the working light corresponds to the ambient light.
 - d. Please check if the working voltage corresponds to the power source.
- The sensitivity is poor:
 - a. Please check if in front of the detection window there are hinder that effect to receive the signals.
 - b. Please check the ambient temperature.
 - c. Please check if the signals source is in the detection fields.
 - d. Please check the installation height.
- The sensor can't shut automatically the load:
 - a. If there are continual signals in the detection fields.
 - b. If the time delay is set to the longest.
 - c. If the power correspond to the instruction.
 - d. If the air temperature change near the sensor, air condition or central heating etc.