

Electromagnetic Flowmeter



Integral Type



Remote Type

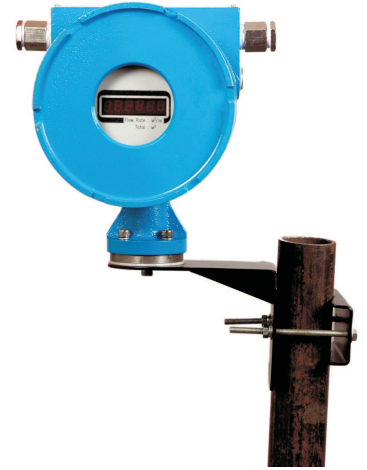

Introduction

Electromagnetic Flowmeter is a new range of Bipolar Pulsed DC Full Bore Type Electromagnetic Flowmeters. It is suitable for pipes with diameters of 10 mm to 1000 mm. They are based on Faraday's law of Electromagnetic Induction. The meter features flanged construction and is available with choice of Liner and Electrode materials. It has excellent accuracy and flow rangeability.

The meter is suitable for use on wide range of corrosive and aggressive range of conductive liquids.

Salient Features

- Based on Faraday's law of Electromagnetic Induction.
- Suitable for pipe sizes of diameters 10 mm to 1000 mm
- Coil Assembly in hermetically sealed Welded construction
- Choice of PTFE / Neoprene Rubber / Polyurethane liners
- Integral or Remote Transmitter
- Field interchangeable electronics
- Optional LED / LCD display for Flow Rate or Totaliser indication in Engineering Units
- No pressure loss
- High linearity due to characteristic magnetic field
- Absolute Zero stability and noise elimination
- Measurement independent of liquid properties

Applications

- Chemical, Petrochemical and Process Industries
- Fertilizer Industries
- Pharmaceutical Industry
- Food Industry
- Drug Industries
- Sugar Industries
- Beverage Industries
- Paper and Pulp Industries
- Aluminum Industries
- Steel Industries
- Mining Industries
- Dredging Industries
- Water and Waste - Water Management
- And many others

Operations

Electromagnetic Flowmeters are based on Faraday's law of Electromagnetic Induction.

In a Electromagnetic Flowmeter, magnetic field is generated by a set of coils. As the conductive liquid passes through the electromagnetic field, an electric voltage is induced in the liquid, which is directly proportional to its velocity. This induced voltage is perpendicular to both the liquid flow direction and the electromagnetic field direction. The voltage sensed by the electrodes is further processed by the transmitter to give standardised output signal or displayed in appropriate Engineering Units on LED/LCD Display.

The flux density of the electromagnetic field in a given Flowmeter and the distance between the electrodes are constant, therefore, the induced voltage is only a function of liquid velocity.

$$E = K.B.\bar{v}.D \text{ where } E : \text{Induced voltage}$$

K : Flow Tube Constant

B : Magnetic field velocity

\bar{v} : Mean flow velocity

and D : Electrode Spacing

Volume flow is calculated by equation :

$$Q = \bar{v}.D^2\pi / 4$$

Therefore, $Q = \frac{E.D.\pi}{K.B.4}$

The induced voltage is not affected by the physical properties of liquid like temperature, viscosity, pressure, density and conductivity, as long as conductivity of the measure liquid is above minimum threshold level. For reliable measurement the pipe must be completely full of liquid.

The electromagnetic field coil assembly is excited by pulsed DC technique, which eliminates the interfering noise and provides automatic zero correction.

Specifications

Suitable for Pipe Sizes	:	DN 10 to DN 1000
Media Conductivity (Min.)	:	10 μ S/cm (Consult factory for 5 μ S/cm)
Media Pressure	:	PN 40 upto DN 80, PN 16 upto DN 200, PN 10 upto DN 1000
Media Temperature (PTFE)	:	0° - 180°C with Remote transmitter
	:	0° - 120°C with Integral transmitter
	:	0° - 90°C max for other liners
Ambient Temperature Range	:	0° - 50°C
Materials : Pipe	:	SS 316 (Non - magnetic)
Liner	:	PTFE / Neoprene / Polyurethane
Electrode	:	SS / Hastelloy C / Ta / Ti / Pt
End Connections / Flanges	:	Carbon Steel / SS 304 / SS 316 / SS 316L
Coil Housing	:	Carbon Steel / SS, Epoxy painted
Transmitter	:	Cast Aluminium (LM6) , Epoxy painted
Flange / End Connection Std.	:	DIN / ANSI / BS / SMS / TRI-CLAMP
Power Supply	:	110 / 240V AC \pm 15%, 50Hz
Power Consumption	:	20 VA
Cable Gland Entry	:	1/2" NPT (F)
Analog Output (Isolated)	:	4-20 mA DC / 0-20 mA DC
Pulsed Output (Optional)	:	Low Pulsed Rate Output 10 to 36000 pulses per hour
		a) Output to drive directly external electromagnetic counter of 12/24V DC @ 200 mA capacity OR
		b) Open Collector Output , High Pulse Rate Output, 0.5 KHz/1 KHz/10KHz/ (Open Collector Output)
Communication Port (Optional)	:	RS - 232 / RS - 485 MODBUS RTU Protocol
Maximum Load Resistance	:	1000 Ω
Response Time	:	5 seconds
Flow Velocity Range	:	0.3 to 10 m/s
Ingress Protection	:	IP - 65 (IP - 68 on request)
LED Display	:	4 Digit Indication for Flow Rate and 8 Digit Indication for Totaliser
		Programming from Front Keyboard for Engineering Units
LCD Display	:	16 X 2 (Two Line) Backlit LCD
Accuracy	:	\pm 0.5% of measured value (calibrated) at reference conditions
For Flow between 20 to 100%	:	\pm 0.5% of measured value (normal)
For Flow between 0 to 20%	:	Refer Error Diagram below
Reference Conditions	:	
Power Supply	:	Nominal
Ambient Temperature	:	25 $^{\circ}$ \pm 2 $^{\circ}$ C
Load Resistance	:	500 Ω
Repeatability	:	\pm 0.2% of span
Effect of Ambient Temperature	:	Less than 0.2% per 10 $^{\circ}$ C
Effect of Power Supply	:	Less than 0.1% per 10% Voltage variation
Effect of Load Resistance	:	Less than 0.1% of span

Error Diagram :

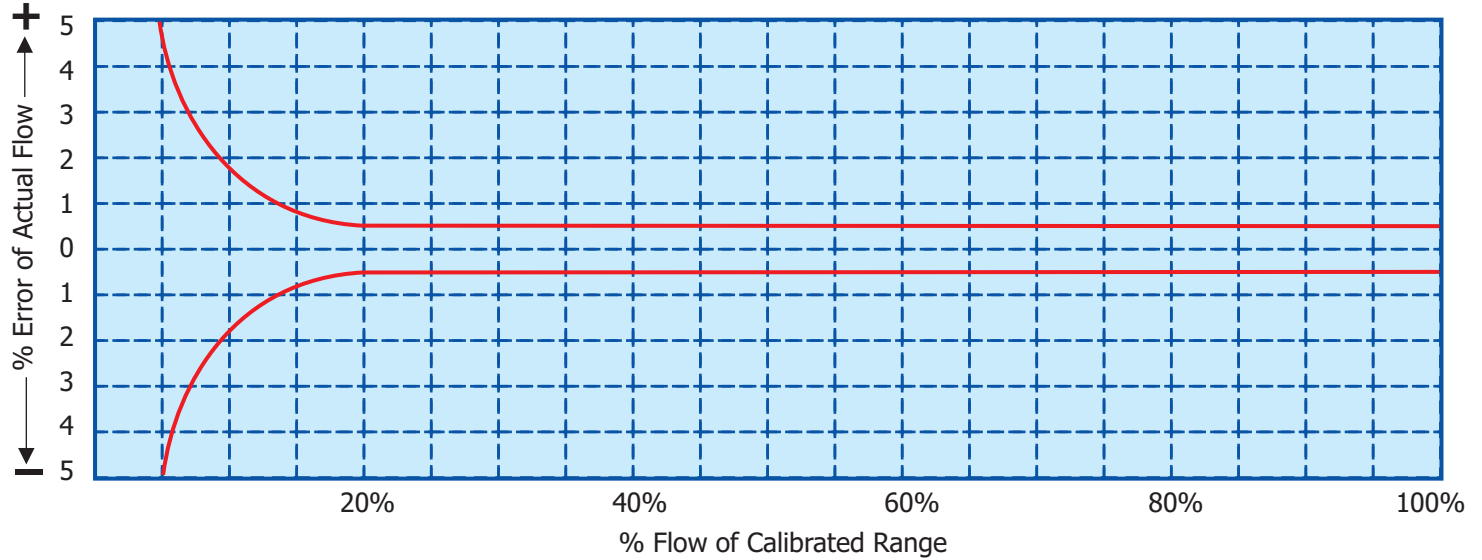

Flow Rate Table Flow Rate at V = 1 m/Sec.

DN	m ³ /Hr	LPM	LPS	DN	m ³ /Hr	LPM	LPS
10	0.282	4.711	0.078	125	44.18	736.198	12.270
15	0.636	10.601	0.176	150	63.61	1060.125	17.668
20	1.130	18.846	0.314	200	113.08	1884.667	31.411
25	1.766	29.447	0.490	250	176.69	2944.792	49.080
32	2.909	48.247	0.804	300	254.43	4240.500	70.675
40	4.523	75.386	1.256	350	346.31	5771.792	96.197
50	7.068	117.791	1.963	400	452.32	7538.668	125.645
65	11.944	199.100	3.317	450	572.47	9541.980	159.036
80	18.092	301.546	5.025	500	706.75	11779.169	196.321
100	28.270	471.166	7.852	600	1017.72	16962.003	282.702

Ordering Information

POWER SUPPLY

- 1) 240 +/- 15% V AC 50 Hz
- 2) 110 +/- 15% V AC 50 Hz

FLOW METER SIZE

- 1) DN 10
- 2) DN 15
- 3) DN 20
- 4) DN 25
- 5) DN 32
- 6) DN 40
- 7) DN 50
- 8) DN 65
- 9) DN 80
- 10) DN 100
- 11) DN 125
- 12) DN 150
- 13) DN 200
- 14) DN 250
- 15) DN 300
- 16) DN 350
- 17) DN 400
- 18) DN 450
- 19) DN 500
- 20) DN 600
- 21) Any other

LINER MATERIAL

- 1) Teflon (PTFE)
- 2) Neoprene
- 3) Hard Rubber
- 4) Polyurethane
- 5) Any other

ELECTRODE MATERIAL

- 1) Stainless Steel 316
- 2) Hastelloy C
- 3) Tantalum
- 4) Titanium
- 5) Platinum
- 6) Any other

FLANGE / END CONNECTIONS

STANDARDS

- 1) DIN PN 40
- 2) DIN PN 16
- 3) DIN PN 10
- 4) ANSI 300
- 5) ANSI 150
- 6) Tri-clamp
- 7) Any other

FLANGE / END CONNECTIONS MATERIAL

- 1) Carbon Steel
- 2) Stainless Steel 304
- 3) Stainless Steel 316
- 4) Any other

COIL HOUSING

- 1) Carbon Steel
- 2) Stainless Steel 304
- 3) Stainless Steel 316

FLOW TRANSMITTER

- 1) Integral without Display
- 2) Integral with Display
- 3) Remote with Display
- 4) Remote without Display

OUTPUT SIGNAL

- 1) 4-20 mA DC
- 2) 0-20 mA DC

PULSED OUTPUT (Optional)

- 1) Low Pulse output
- 2) High Pulse output
- 3) Nil

COMMUNICATION PORT (Optional)

- 1) RS - 232
- 2) RS - 485

- Notes :**
- 1) Flowmeter is supplied with 2 Nos. of SS 316 Earthing Rings of 3 mm thickness.
 - 2) Remote Flow Transmitter is supplied with 2" Pipe Mounting Kit and 10 meter each electrode signal cable and coil supply cable.
 - 3) Installation location should be such that the Flowmeter will always remain full with liquid.
 - 4) A minimum 5D upstream and 3D downstream straight lengths should be maintained at installation location. where D is the pipe diameter. The Flowmeter installation location should be free of bends, elbows, tees, valves etc.

Dimensional Drawing :

Integral Type

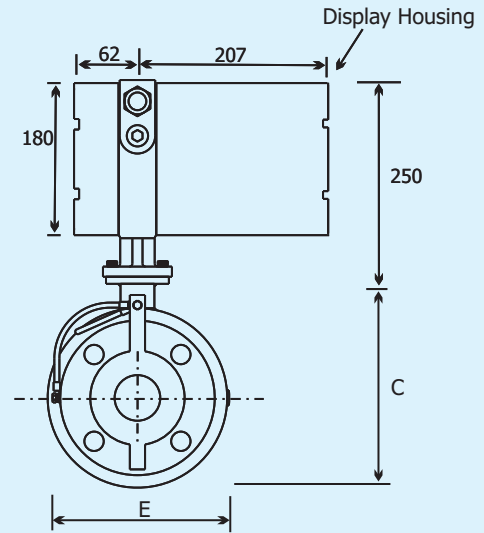
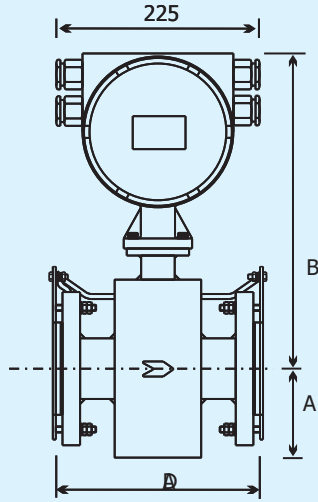

Remote Type

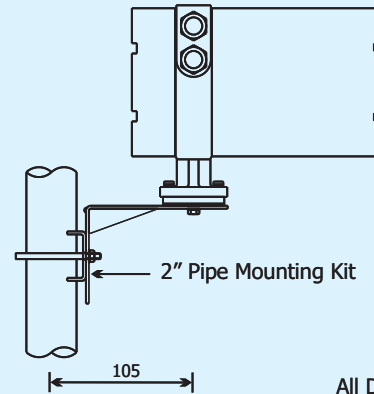
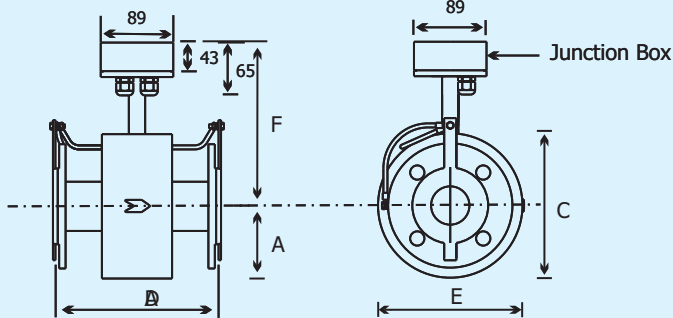

All Dimensions in mm

End to End Dimensions in mm

DN (mm)	A	B	C	D	E	F
10, 15, 20	65	310	125	200	120	190
25, 32	80	325	155	200	150	205
40, 50	120	365	230	200	225	245
65, 80	130	375	250	200	245	255
100, 125	170	415	330	250	325	295
150	190	435	370	300	365	315
200	245	490	480	350	475	370
250	295	540	580	400	575	420
300	335	580	660	500	655	460
350	360	605	710	500	705	485
400	395	640	780	600	775	520
450	430	675	855	600	850	555
500	465	710	925	600	920	590
600	550	795	1090	600	1085	675
700	646	925	1215	700	1230	780
750	705	1100	1350	750	1360	910
800	755	1225	1460	800	1475	1025
900	840	1350	1550	900	1565	1130
1000	955	1600	1680	1000	1700	1245

- Notes : 1. Above dimensions are with ANSI 150 / DIN PN 16 flanges (For other flanges - Consult Factory)
2. Add total 6mm for two earthing / Linear protection rings to dimension 'D'

Continuous efforts for product development may necessitate changes in these details without notice

Manufactured by:



JAYCEE TECHNOLOGIES PVT. LTD.

Shed No.7, Nanekar Industries Building, Survey No. 79/2,
Dangat Industrial Estate, Shivane, Pune - 411 023, India.
■ Tel. : 020 - 64703186, ■ Tel./Fax : 020 - 25290744
■ Email : jayceetech@vsnl.net ■ jayceetech@gmail.com
■ Website : www.jayceetech.com