

Product Information

**Flow Meter
GR-065GK**



- Minimum measurement quantity
- Convex cut for enlargement
- Optionally valve
- Good resistance to medium

Characteristics

A float moves in a transparent conical measurement tube, relative to the flow. The position of the float depends on the volume flow (weight force versus resistance to flow), and indicates the flow rate on the scaled measurement tube.

Technical data

Switch	without	
Nominal width	DN 4	
Process connection	female thread 1/8" NPT	
Metering range	0.002..43.3 l/min	for details see table "Ranges"
Q _{max.}	120 % of full scale value	
Tolerance	±5 % of full scale value	
Pressure resistance	PN 12 bar	
Medium temperature	-20..+90 °C	
Ambient temperature	-20..+70 °C	
Media	water, gases	
Electrical data	none	
Materials medium-contact	borosilicate glass , glass, stainless steel, FKM	
Non-medium-contact materials	glass, CW614N valve: ABS, CW614N	
Weight	0.5 kg	
Installation location	vertical inwards flow from below	

Ranges

The details in the table correspond to a vertical inwards flow from below.

The metering ranges for air correspond to a temperature of the medium of 0 °C and a pre-pressure of 1.013 bar.

The scale has millimetre divisions. With the aid of the conversion diagrams included in the scope of the delivery, the flow rate can rapidly be determined.

Metering range Air cm³/min	Metering range H ₂ O cm³/min	Float	Types
2 - 51		Glass	GR-065GK0005G
5 - 103		Stainless steel	GR-065GK0010G
5 - 153			GR-065GK0015K
10 - 298		Glass	GR-065GK0029K
20 - 400			GR-065GK0040G
40 - 855	0.90 - 21.0	Stainless steel	GR-065GK0085K
20 - 900	0.20 - 18.2	Glass	GR-065GK0090G
50 - 1800	1.00 - 50.0	Stainless steel	GR-065GK0180K
100 - 2580	2.00 - 55.0	Glass	GR-065GK0258G
100 - 3930	2.00 - 90.0		GR-065GK0393G
277 - 5030	3.27 - 144.0	Stainless steel	GR-065GK0503K
100 - 6000	2.00 - 130.0	Glass	GR-065GK0600G
300 - 7510	5.00 - 220.0	Stainless steel	GR-065GK0751K
150 - 10100	3.00 - 235.0	Glass	GR-065GK1010G
250 - 11450	5.00 - 335.0	Stainless steel	GR-065GK1145K
800 - 15750	10.00 - 375.0	Glass	GR-065GK1575G
400 - 18960	10.00 - 560.0	Stainless steel	GR-065GK1896K
700 - 23640	10.00 - 570.0		GR-065GK2364G
2000 - 29400	42.00 - 881.0	Stainless steel	GR-065GK2940K
2000 - 43340	50.00 - 1305.0		GR-065GK4334K

Dimensions

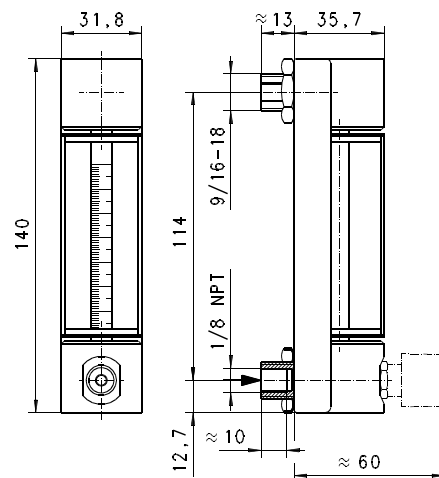

Product Information

Handling and operation

- Include straight calming section of 5 x DN in inlet and outlet
- If the media are dirty, install a filter

Ordering code

GR 1. 2. 3. 4. 5. 6.

GR **065** **G**

○=Option

1. Valve			
-	without valve		
V-	with valve		
2. Length of scale			
065	65 mm		
3. Process connection			
G	female thread		
4. Connection material			
K	stainless steel		
A	○ aluminium		
M	○ brass		
5. Display range cm³/min for vertical inwards flow			
	Air (0 °C, 1.013 bar abs.)	Water	
0005	2 - 51		●
0010	5 - 103		●
0015	5 - 153		●
0029	10 - 298		●
0040	20 - 400		●
0085	40 - 855	0.90 - 21.0	●
0090	20 - 900	0.20 - 18.2	●
0180	50 - 1800	1.00 - 50.0	●
0258	100 - 2580	2.00 - 55.0	●
0393	100 - 3930	2.00 - 90.0	●
0503	277 - 5030	3.27 - 144.0	●
0600	100 - 6000	2.00 - 130.0	●
0751	300 - 7510	5.00 - 220.0	●
1010	150 - 10100	3.00 - 235.0	●
1145	250 - 11450	5.00 - 335.0	●
1575	800 - 15750	10.00 - 375.0	●
1896	400 - 18960	10.00 - 560.0	●
2364	700 - 23640	10.00 - 570.0	●
2940	2000 - 29400	42.00 - 881.0	●
4334	2000 - 43340	50.00 - 1305.0	●
6. Float			
G	glass		
K	stainless steel		

Options

- Float made from sapphire, tantalum, or carbon
- Brass valve
- Valve with fine adjustment
- special ranges are possible

Ordering information

- Specify direction of flow, medium, and display range.
- For gases, state pressure (relative or absolute), temperature and medium (e.g. air) (request display range)