



PRODUCT PROFILE & 4+1 Axis Bridge saw cutting machine :DSQJ-400



WELCOME



ABOUT THE COMPANY

Established in 2012 as **FUSION TECHNOCRAFT** and incorporated as an LLP on May 17, 2018, **FUSION CNC TECHSYSTEMS LLP** is a leading manufacturer and importer of advanced CNC Stone Carving and Cutting Machine technology and stone diamond tools. Under the visionary leadership of **Mr. Manish Sukhadia**, Founder and Managing Partner, the company specializes in a diverse product range including CNC engraving and cutting machines, profiling machines, stone temple and pillar carving systems, sculptures, granite monuments, and tombstone machinery. Renowned for exceptional performance, high durability, low maintenance costs, and competitive pricing, Fusion CNC ensures the highest quality by using premium raw materials and maintaining a robust network of trusted vendors with an efficient bulk manufacturing infrastructure. Driven by innovation and guided by experience, Fusion CNC continues to build a strong presence in the stone processing machinery industry and shape excellence in CNC technology and stone craftsmanship.



+900
CUSTOMER



+100
PROJECT DONE

13+
YEARS OF EXPERIENCE

Automatic 4+1 axis bridge saw cutting machine



Machine Main function:

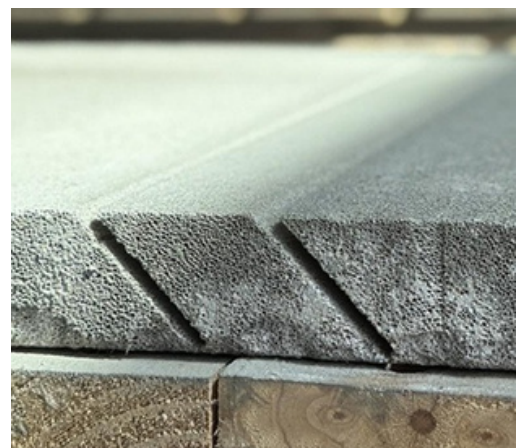
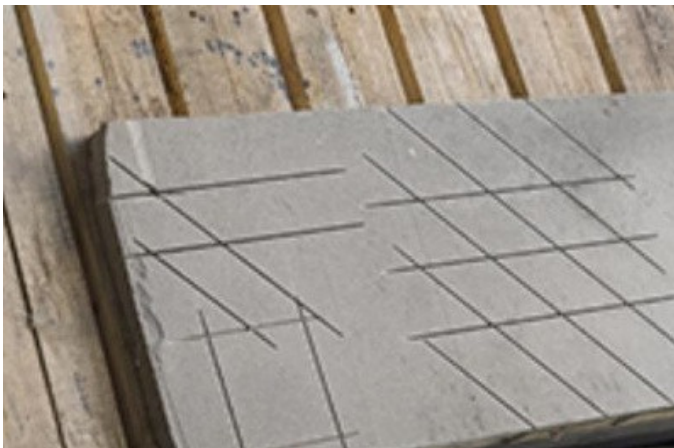
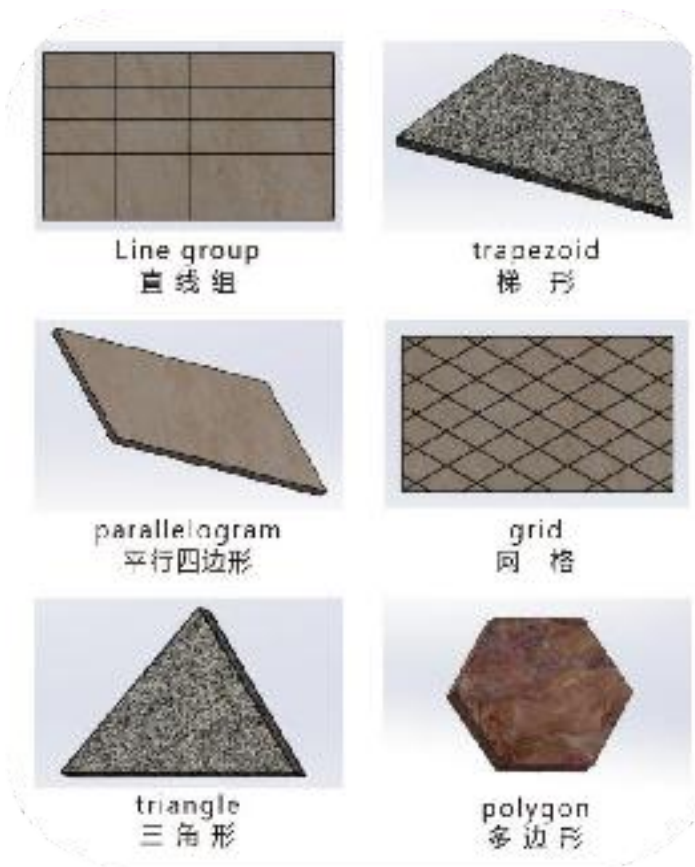

Machine Application:

The machine can cut quartzstone, marble, Granite, stone slate and other decorative materials through the saw blade. The saw blade and its tool are combined, and one machine is multi-functional. It is widely used in stone processing plants, kitchen countertop processing.

Technical parameters:

Model	Unit	4+1 Axis
Max. Diameter of Diamond Saw Blade	mm	350-600mm
Max. cutting Size (LxWxH)	mm	3200x2000x180 mm
Table Size	mm	3200x2000 mm
Table Tilting	n°	85°
Degree Saw Blade	n°	0-360°
Rotation Degree Saw	n°	45°
Blade Tilting Degree (Hydraulic)	m ³ /h	3
Water Consumption Main Motor	kw	18.5 KW
Power Machine Specification (LxWxH)	mm	5000X2675X2500
Machine Weights	kgs	4000 Kgs
Configuration:		
Bearing	Harbin	
High precision linear guide	Taiwan	
Main motor	Xiamen Eagle motor 18.5KW	
Spindle Converter	Ouri 18.5 KW	
Reducer motor	Planetary High Precision	
Hydraulic Oil pump	Taiwan pump	
Electrical components	Schneider	
Control System	FUSION	
Table Steel	14#	

Machine Drawing:

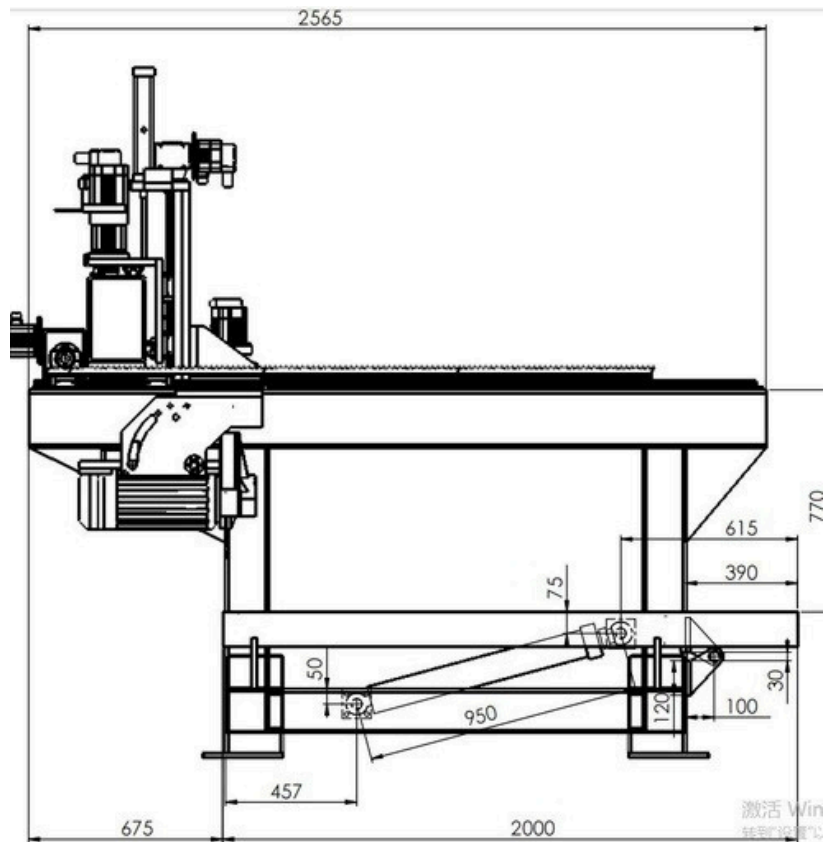
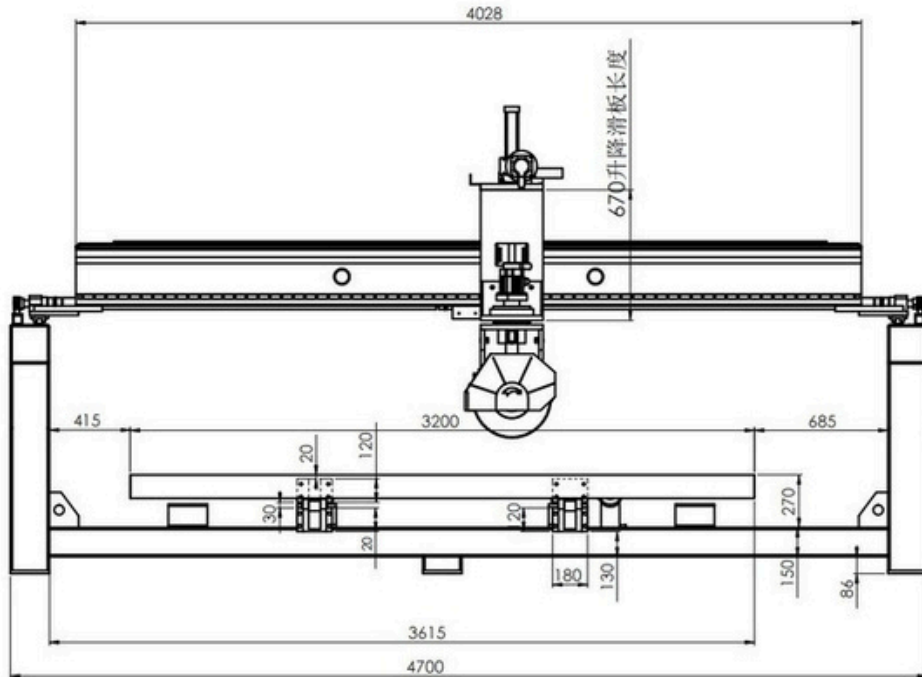

<p align="center">PRICE</p>	<p>AED 86,903.00 (Eighty-six thousand nine hundred three dirhams only.)</p>
<p>Payment Terms & Conditions</p> <p>FOB Charges</p> <p>Warranty Period</p> <p>Delivery</p> <p>Payment</p> <p>Order Confirmation</p> <p>Installation & Training</p> <p>Training</p> <p>Validity of Quotation</p> <p>Bank Details</p>	<p>All the Prices quoted are CIF Mundra/Pipava Port.</p> <p>1. One year against faulty parts of the CNC machine. Machine warranty is start from Invoice date one year's warranty. 2. Our warranty of machine does not cover the damages caused through fire created by any means, outside force, operation's mistake, natural calamity Items not covered under warranty such as Tool & Collet. No Warranty for Vacuum pipes and dust collector pipes. 3. Spindle have 6 months warranty</p> <p>Within 45 to 55 days after receipt of payment.</p> <p>90% TT AED 78,212.00 Advance with Purchase order copy 10 % AED 8691.00 After installation same day Transfer</p> <p>Once the offer is accepted by purchaser by purchase order in writing or on receipt of the advance amount, such order shall be deemed to be confirmed orders. If the purchase order is cancelled then the advanced payment amount is not refundable.</p> <p>Will depute engineer for commissioning of machines at customer's site on receipt of customer's confirmation for readiness of necessary electrical connections, compressed air connections and tooling etc. All necessary lodging and boarding expenses, Visa and up-down Air Ticket will be paid by the customer.</p> <p>Installation & Training will be provided by our engineers at customer's place. To & from Airfares well as boarding & lodging cost will be borne by customer.</p> <p>The prices quoted are valid for 30 days from the date of quotation</p> <p>Our Authorized Dealer Code -6392602 SWIFT CODE - ICICINBBCTS IFSC Code of the Science City Branch - ICICI0001826 BSR Code of the bank -5700009</p>

For Service During warranty period free of cost, Only actual expense for traveling, boarding and lodging will be from Customer side.

<p align="center">Dispute</p>	<p>All disputes will be subject to Ahmedabad jurisdiction</p>
--------------------------------------	---



PROUD TO BE MEMBER OF



CONTACT US

FUSION CNC TECHSYSTEMS LLP



Corporate Office: A 1104-1105, Money Plant High Street, Jagatpur Road, Sarkhej - Gandhinagar Hwy, nr. BSNL Office, Gota, Ahmedabad, Gujarat 382470 **Factory:** Plot No. 3, Dantali Industrial Estate, Village, Dantali Taluka Kalol, Dist. Gandhinagar (India) 382721



+91 9824236644
+91 7861866734



info@fusioncnc.in
sales@fusioncnc.in