

## SPnorm & SPbloc Self Priming Centrifugal Pumps

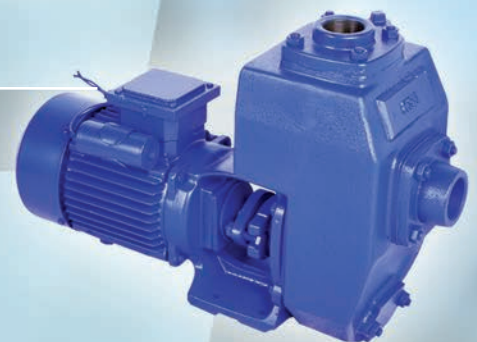

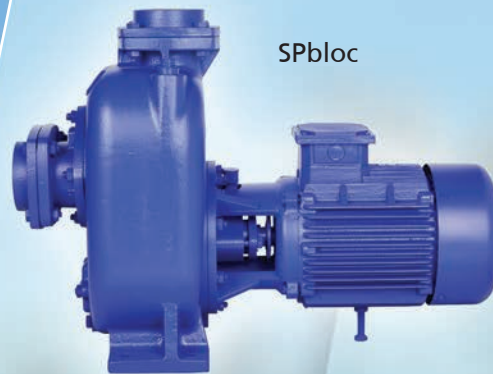
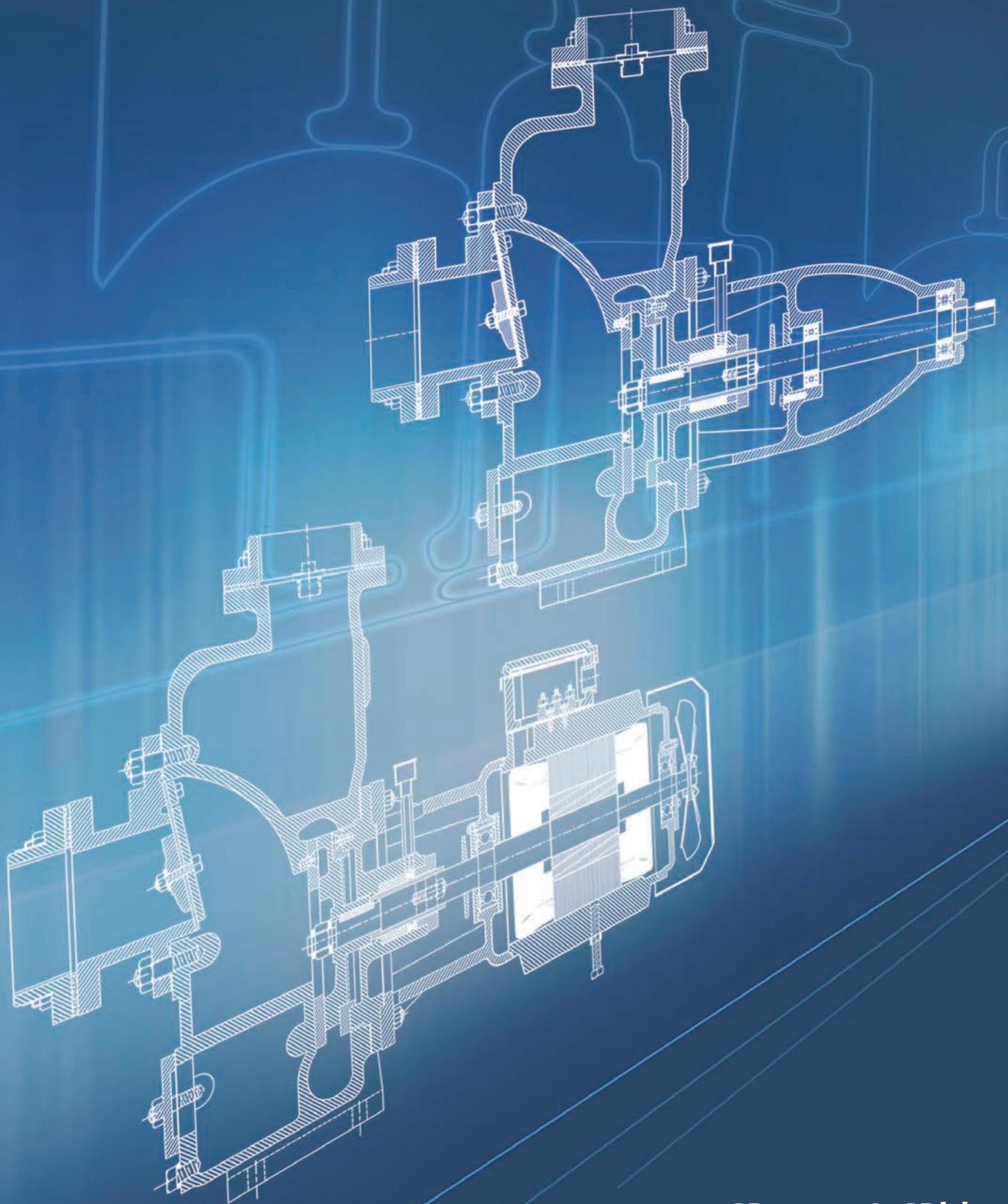

**SPnorm & SPbloc**  
Self Priming Centrifugal Pumps

# SPnorm & SPbloc - Self Priming Centrifugal Pumps



## Design

### SPnorm:

Horizontal self priming volute casing pumps, single stage with semi open impeller, in back pull out design. Long coupled on baseplate, suction lift up to 7 metres.

Technical specifications conforms to **IS 8472 & IS 8418**.

Performance Testing as per **IS 11346**.

### SPbloc:

Horizontal self priming volute casing pumps, single stage with semi open impeller, in back pull out design. Monobloc, mono shaft design, hydraulics are assembled on extended motor shaft, suction lift up to 7 metres.

Technical specifications conforms to **IS 8472 & IS 8418**.







Performance Testing as per **IS 11346**.

## Applications

### Suitable pump for pumping

1. Muddy water, sewage, polluted liquids including solids etc.
2. Applications where priming & foot valve is to be avoided.

### Industry wise Applications:

-  **Industrial:** Pumping petroleum products, chemicals, effluents, Sewage, ash-water etc
-  **Mobile Machinery:** Cooling water for marine engines & showels.
-  **Tiles & Marble industry:** for handling waste water.
-  **Civil Construction:** De-watering foundation, trenches and pits.
-  **Public utilities:** Sewage pumping.
-  **Marine:** Pumping water from docks, ports, vessels.

## Technical Data

		SPbloc (monobloc)	SPnorm (barepump)
Head	m	6 to 36	6 to 50
Capacity	LPS	up to 19.4	up to 71
	m <sup>3</sup> /hr	up to 70	up to 253
Power rating	HP	1 to 7.5	1 to 25
	kW	0.75 to 5.5	0.75 to 18.5
DN size		DN 40, 50, 80	DN 40, 50, 80, 100, 150
MOC	Pump body	C.I.	C.I., SS
	Motor body	C.I.	-
	Impeller	C.I., SS, Bronze	C.I., SS, Bronze
	Wear plate	C.I., SS	C.I., SS
	Shaft	SS 410	SS 410, 316, 304
	Shaft sleeve	SS 410	SS 410, 316, 304
Sealing		Gland packing or mechanical seal	Gland packing or mechanical seal
Driver			Motor or Engine







## Cross Sectional View - SPnorm 14 (Reference Drawing)

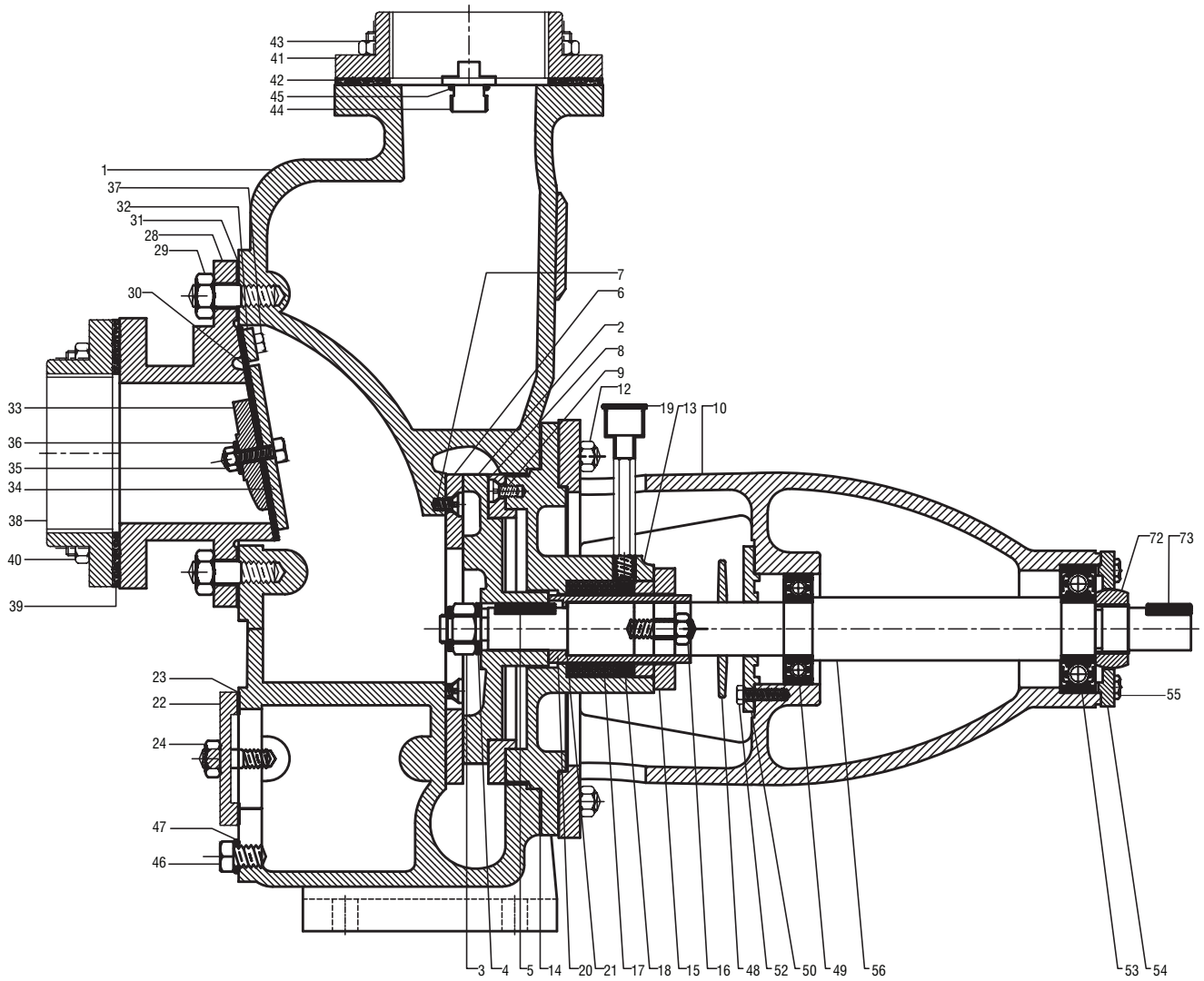

29	Stud with Nut for Suction housing	4	M.S.
28	Suction Housing	1	C.I. Gr. FG-260
24	Stud with Nut for Insp. window cover	2	M.S.
23	Packing for Insp. window cover	1	Paper
22	Insp window cover	1	C.I. Gr. FG-260
21	Gasket	1	Paper
20	Shaft Sleeve	1	S.S. Gr. AISI410
19	Grease Cup with Pipe Nipple	1	M.S.
18	Lantern ring	1	Plastic
17	Gland Packing	1 Set	Graphite Asbestos
16	Hex. bolt or Stud with Nut for Gland cover	2	M.S.
15	Gland Cover	1	C.I. Gr. FG-260
14	Packing for Stuffing Box Housing	1	Paper
13	Stuffing Box Housing	1	C.I. Gr. FG-260
12	Stud with Nut for Brg. housing & St. box housing	8	M.S.
11	Packing for Bearing housing	3	Paper
10	Bearing Housing	1	C.I. Gr. FG-260
9	Counter Sunk Screw for Wearing Plate	3	S.S. Gr. AISI304
8	Wearing Plate (DE)	1	C.I. Gr. FG-260
7	Counter Sunk Screw for Wearing Plate	3	S.S. Gr. AISI304
6	Wearing Plate (NDE)	1	C.I. Gr. FG-260
5	Key for Impeller Nut	1	M.S.
4	Washer for Impeller Nut	1	M.S.
3	Impeller Nut	1	M.S.
2	Impeller	1	C.I. Gr. FG-260
1	Pump Body	1	C.I. Gr. FG-260
<b>Part no</b>	<b>Part Description</b>	<b>Qty</b>	<b>Material</b>

73	Key for Coupling	1	M.S.
72	Bearing Lock Nut	1	M.S.
56	Rotar Shaft	1	CRNO Gr. M-47 & EN-8D
55	Cheese Head Screw for Bearing cover (DE side)	4	M.S.
54	Bearing Cover (DE side)	1	C.I. Gr. FG-260
53	Bearing (DE side)	1	Steel
52	Cheese Head Screw for Bearing cover (NDE side)	3	M.S.
50	Bearing Cover (NDE side)	1	C.I. Gr. FG-260
49	Bearing (NDE side)	1	Steel
48	Water Deflector	1	Rubber
47	O-Ring for Drain Plug	1	Rubber
46	Drain Plug	1	C.I. Gr. FG-260
45	O-Ring for Water Plug	1	Rubber
44	Water Plug (for Priming)	1	C.I. Gr. FG-260
43	Stud with Nut for Delivery flange	4	M.S.
42	Packing for Delivery flange	1	Rubber
41	Delivery flange	1	C.I. Gr. FG-260
40	Stud with Nut for Suction flange	4	M.S.
39	Packing Suction Flange	1	Rubber
38	Suction Flange	1	C.I. Gr. FG-260
37	Cheese Head Screw for Wt. fixing	2	M.S.
36	Washer for Flap valve	1	M.S.
35	Hex. bolt with Nut for Flap valve	1	M.S.
34	Weight for Flap valve (big)	1	C.I. Gr. FG-260
33	Weight for Flap valve (medium)	1	C.I. Gr. FG-260
32	Weight for Flap valve (Small)	1	C.I. Gr. FG-260
30	Flap valve	1	Nitril Rubber
<b>Part no</b>	<b>Part Description</b>	<b>Qty</b>	<b>Material</b>

## Cross Sectional View - SPbloc 14M (Reference Drawing)

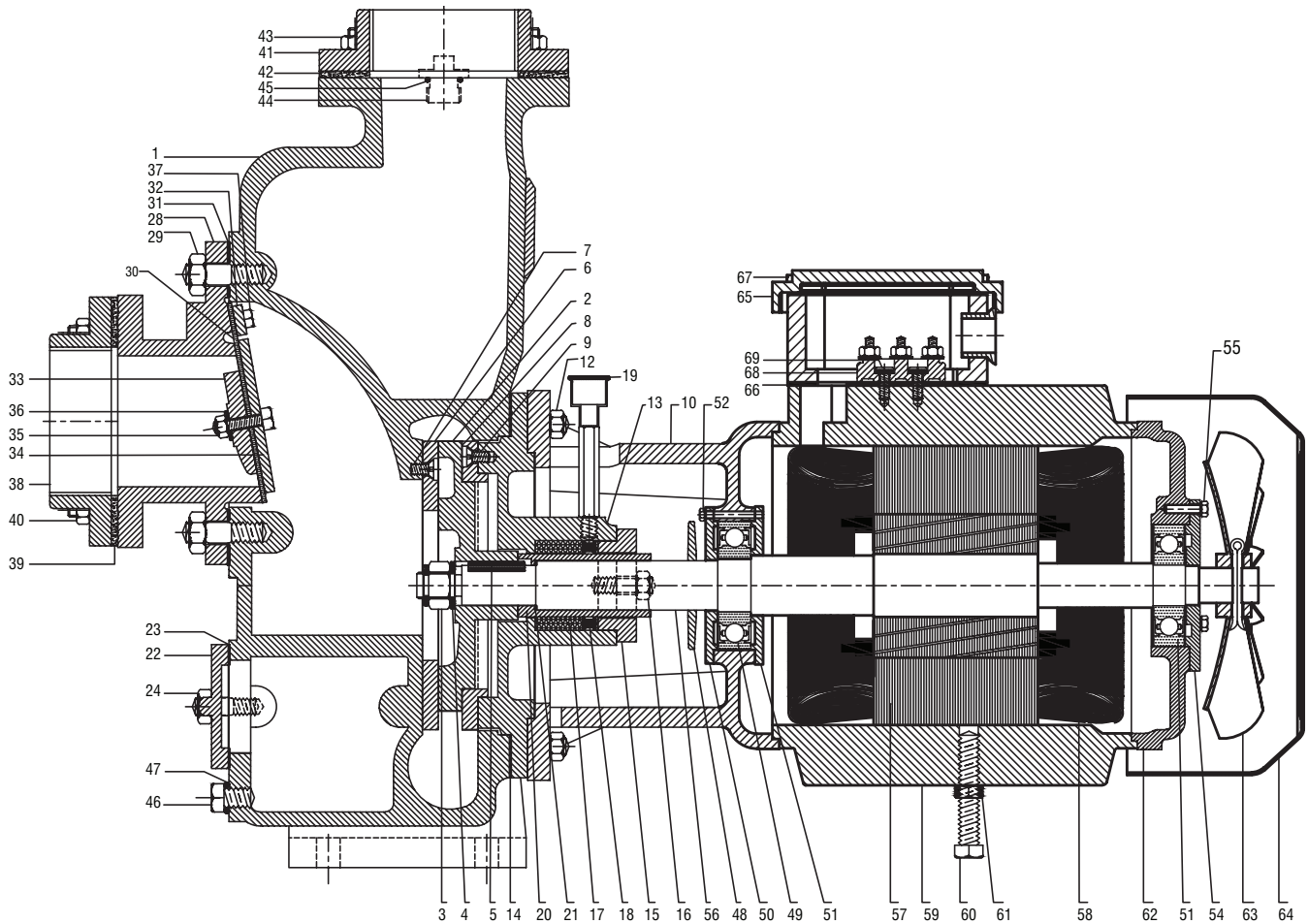

37	Cheese Head Screw for Wt. fixing	2	M.S
36	Washer for Flap valve	1	M.S.
35	Hex. bolt with Nut for Flap valve	1	M.S.
34	Weight for Flap valve (big)	1	C.I. Gr. FG-260
33	Weight for Flap valve (Medium)	1	C.I. Gr. FG-260
32	Weight for Flap valve (Small)	1	C.I. Gr. FG-260
31	Packing for Flap valve	1	Paper
30	Flap valve	1	Nitril Rubber
29	Stud with Nut for Suction housing	4	M.S.
28	Suction Housing	1	C.I. Gr. FG-260
24	Stud with Nut for Insp. window cover	2	M.S.
23	Packing for Insp. window cover	1	Paper
22	Insp window cover	1	C.I. Gr. FG-260
21	Gasket	1	Paper
20	Shaft Sleeve	1	S.S. Gr. AISI410
19	Grease Cup with Pipe Nipple	1	M.S.
18	Lantern ring	1	Plastic
17	Gland Packing	1 Set	Graphite Asbestos
16	Hex. bolt or Stud with Nut for Gland cover	2	M.S.
15	Gland Cover	1	C.I. Gr. FG-260
14	Packing for Stuffing Box Housing	1	Paper
13	Stuffing Box Housing	1	C.I. Gr. FG-260
12	Stud with Nut for Brg. housing & St. box housing	8	M.S.
10	Bearing Housing	1	C.I. Gr. FG-260
9	Counter Sunk Screw for Wearing Plate	1	S.S. Gr. AISI304
8	Wearing Plate (DE)	1	C.I. Gr. FG-260
7	Counter Sunk Screw for Wearing Plate	3	S.S. Gr. AISI304
6	Wearing Plate (NDE)	1	C.I. Gr. FG-260
5	Key for Impeller Nut	1	M.S.
4	Washer for Impeller Nut	1	M.S.
3	Impeller Nut	1	M.S.
2	Impeller	1	C.I. Gr. FG-260
1	Pump Body	1	C.I. Gr. FG-260
<b>Part No.</b>	<b>Description</b>	<b>Qty</b>	<b>Material</b>

69	Cheese Head Screw for Terminal	4	M.S.
68	Terminal	1	Bakelite
67	Cheese Head Screw for Terminal Box	4	M.S.
66	Packing for Terminal Box	1	Rubber
65	Terminal Box	1	C.I. or M.S. Sheet
64	Fan Cover	1	M.S. Sheet
63	Fan	1	Plastic
62	End Cover	1	C.I. Gr. FG-260
61	Washer for Motor Adjustment Bolt	1	M.S.
60	Motor Adjustment Bolt	1	M.S.
59	Motor Body	1	C.I. Gr. FG-260
58	Stator Winding	1	Copper
57	Stator	1	CRNO Gr. M-47
56	Rotor Shaft	1	CRNO Gr. M-47 & EN-8D
55	Cheese Head Screw for Bearing cover (DE side)	4	M.S
54	Bearing Cover (DE side)	1	C.I. Gr. FG-260
53	Bearing (DE side)	1	Steel
52	Cheese Head Screw for Bearing cover (NDE side)	4	M.S
51	Bearing Cover (In Side)	1	C.I. Gr. FG-260
50	Bearing Cover ( Out side)	1	C.I. Gr. FG-260
49	Bearing (NDE side)	1	Steel
48	Water Deflector	1	Rubber
47	O-Ring for Drain Plug	1	Rubber
46	Drain Plug	1	C.I. Gr. FG-260
45	O-Ring for Water Plug	1	Rubber
44	Water Plug (for Priming)	1	C.I. Gr. FG-260
43	Stud with Nut for Delivery flange	4	M.S.
42	Packing for Delivery flange	1	Rubber
41	Delivery flange	1	C.I. Gr. FG-260
40	Stud with Nut for Suction flange	4	M.S
39	Packing Suction Flange	1	Rubber
38	Suction Flange	1	C.I. Gr. FG-260
<b>Part No.</b>	<b>Description</b>	<b>Qty</b>	<b>Material</b>

# KSB Pumps and Valves - We are where you are

## Manufacturing Plants :

### Head Office & Pimpri :

#### Irrigation & Process Division

Mumbai-Pune Road, Pimpri,  
Pune - 411 018.

Tel.: 020-2710 1000 Fax : 020-2742 6000

### Chinchwad :

#### Power Projects Division

D-II Block, MIDC Chinchwad,  
Pune - 411 019.

Tel.: 020-2740 9100 Fax : 020-2747 0890

### Khandala :

#### Energy Pumps Division

A1, MIDC Khandala Phase II,  
Village Kesurdi, Tal. Khandala,  
Satara - 412 802.

Tel. : 02169 -246800

### Coimbatore :

#### Valves Division

151, Mettupalayam Road,  
NSN Palayam Post,  
Coimbatore - 641 031.

Tel.: 0422-2468222, 2468547-9

Fax : 0422-2468232

### Sinnar :

#### Standard Pumps Division

Plot No. E-3 & E-4, MIDC Sinnar,  
Nashik - 422 113.

Tel.: 02551-230252 / 53, 229700

Fax : 02551-230254

### Vambori :

#### Foundry Division

Vambori, Ahmednagar - 413 704.

Tel.: 02426-272534, 272550, 272463

Fax : 02426-272043

## Regd. Office :

126, Maker Chambers III, Nariman Point,  
Mumbai - 400 021.

Tel.: 022-6658 8787 Fax : 022-6658 8788

## Zonal Offices :

### East :

30, Circus Avenue, 2nd Floor,  
Kolkata - 700 017.

Tel.: 033-2287 0473, 2290 0117

Fax : 033-2287 0588

### West :

126, Maker Chambers III, Nariman Point,  
Mumbai - 400 021.

Tel.: 022-6658 8787 Fax : 022-6658 8788

### North :

KSB House, A-96, Sector IV, NOIDA,  
Dist. Gautam Budh Nagar - 201 301.

Tel.: 0120-254 1091

Fax : 0120-255 0567

### South :

Guindy House, II Floor, # 92 Anna Salai,  
Chennai - 600 032.

Tel.: 044-2235 2571-2, 2235 5673

Fax : 044-2235 2749

## Service Stations :

### Chennai :

# 6, Self-help Industrial Estate,  
Keelkattalai, Near Keelkattalai -

Pallavaram Radial Road Signal junction,  
Chennai 600 117

Tel. 044-22681159

### Howrah :

Sadananda Industrial Estate

Howrah Amta Road, Balitikuri,  
Bakultala

Howrah - 711 113, West Bengal

### NOIDA :

KSB House, A-96, Sector IV, NOIDA,  
Dist. Gautam Budh Nagar - 201 301.

Tel.: 0120-2471 600

Fax : 0120-255 0567

### Odhav :

Shed No. 22, Gujarat Vepari

Mahamandal, Odhav,  
Ahmedabad - 382 410.

Tel.: 079-2290 0372

Fax : 079-2290 0749

## Branch Offices :

### Ahmedabad :

Shed No. 22, Gujarat Vepari

Mahamandal, Odhav,  
Ahmedabad - 382 410.

Tel.: 079-2290 0707, 2290 0717

### Aurangabad :

Plot No. P-204, Shivshankar Colony,  
Near Hotel Sayli,

Aurangabad - 431 005.

Tel.: 0240-235 1440, 234 2447

Fax : 0240-235 1440

### Bangalore :

# 191, 1st Floor, West Of Chord Road,  
II Stage, Bangalore - 560 086.

Tel.: 080-2349 1806, 2349 3925

Fax : 080-2349 6036

### Baroda :

4-B, Ramkrishna Chamber,

Productivity Road, Baroda - 390 005.

Tel.: 0265-233 0532, 233 3226

Fax : 0265-235 0002

### Bhubaneswar :

N5/39, 1st Floor, IRC Village, Nayapalli,  
Bhubaneswar - 751 015.

Tel.: 0674-255 8497

Fax : 0674-255 8499

### Chandigarh :

SCO - 189, 2nd Floor, Sector - 7C,  
Chandigarh - 160 019.

Tel. / Fax : 0172-279 0072, 279 0062

### Indore :

B-14, Ratlam Kothi, Kanchan Baug  
Road, Indore - 452 001.

Tel.: 0731-252 9478, 252 9704

Fax : 0731-252 9704

### Jaipur :

Anjali Chambers, 2nd Floor, Block C,  
10, Rajbhawan Road, Civil Lines,  
Jaipur - 302 001.

Tel.: 0141-222 4554, 222 4904

Fax : 0141-222 4904

### Jamshedpur :

Flat No. B-1/5, 1st Floor,

Gangotri House, Q Road, 1, Sura  
Bhawan Area, South Park, Bistupur,  
Jamshedpur - 831 001.

Tel.: 0657-231 7129, 231 7130

Fax : 0657-231 7128

### Lucknow :

309, Chintels House, 16, Station Road,  
Lucknow - 226 001.

Tel.: 0522-263 5203, 263 5597

Fax : 0522-263 5597

### Mumbai :

126, Maker Chambers III, Nariman Point,  
Mumbai - 400 021.

Tel.: 022-6658 8787

Fax : 022-6658 8788

### Nagpur :

203, Suryakiran Complex, Bajaj Nagar,  
Nagpur - 440 010.

Tel.: 0712-223 6889, 222 9148

Fax : 0712-222 9148

### Pune :

Mumbai-Pune Road, Pimpri,  
Pune - 411 018.

Tel.: 020-2710 1000 Fax : 020-2742 6000

### Raipur :

D-62, Sector - 2, Devendra Nagar,  
P.O. Pandri, Raipur - 492 001.

(Chhattisgarh).

Tel.: 0771-258 3658, 258 3921

Fax : 0771-258 3921

### Secunderabad :

D. No. 12-13-197, 198,

Flat No. 103 & 104, 1st Floor,

Pavani Anusuya Towers, Tarnaka,  
Secunderabad - 500 017.

Tel.: 040-2700 1724, 2700 3696

Fax : 040-2700 1725



**KSB Pumps Limited**  
**Standard Pumps Division**

Plot No. E-3 & E-4, MIDC Sinnar, Nashik - 422 113.  
Tel.: +91-2551-230252 / 253, 229700 www.ksbindia.co.in

**Our toll free no : 1800 233 1299**  
(Mon-Sat. 8am to 10pm)

Mktg. Services / 04 -18 / 2000