

kds PUMPS

- the heart of Industry



 **One Stop Pumping Solution...**



Performance Curve

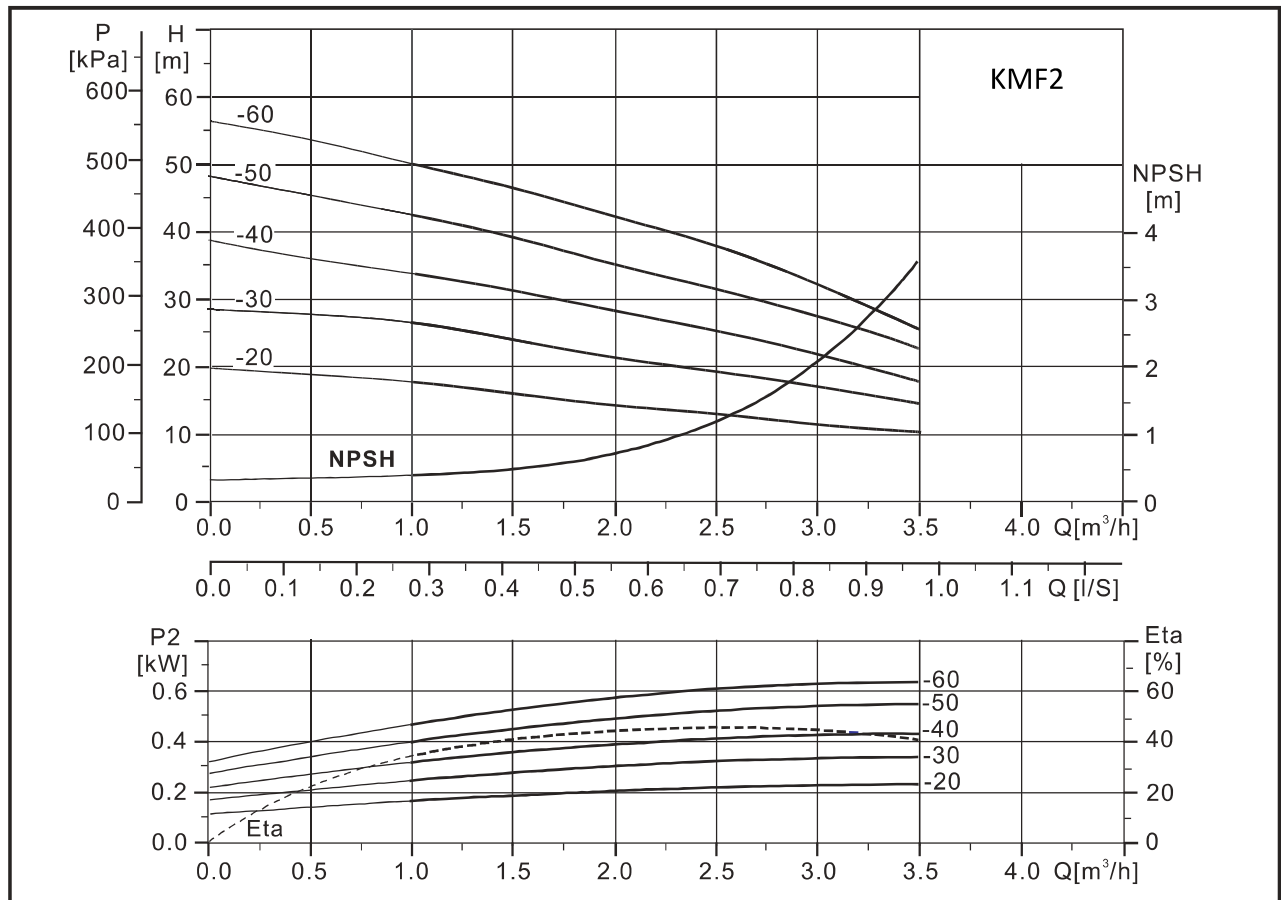

Performance Table

Modal		Driving Moter p ₂	Q (m3/h)	H (m)					
Single Phase	Three Phase			1	1.5	2	2.5	3	3.5
KMF 2-20	KMF 2-20T	0.37	H (m)	18	16	14	13	11	10
KMF 2-30	KMF 2-30T	0.37		27	24	21	20	17	14
KMF 2-40	KMF 2-40T	0.55		35	32	28	26	23	17
KMF 2-50	KMF 2-50T	0.55		43	40	35	33	28	22
KMF 2-60	KMF 2-60T	0.75		50	48	42	38	32	25

Installation Sketch

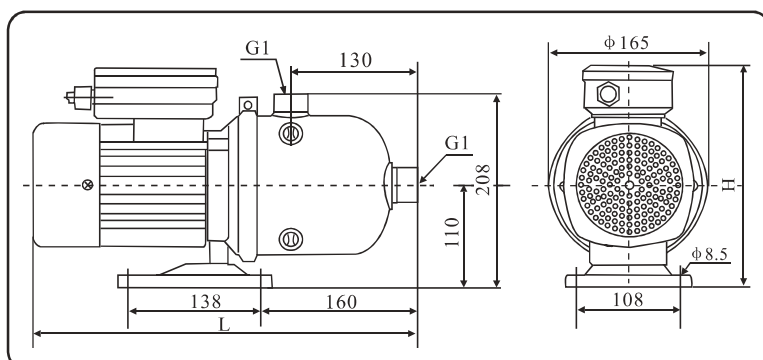

Model	Size(mm)				Weight (kg)
	Single-Phase		Three-Phase		
	L	H	L	H	
KMF 2-20(T)	405	235	405	215	9
KMF 2-30(T)	405	235	405	215	9.5
KMF 2-40(T)	405	235	405	215	10
KMF 2-50(T)	405	235	405	215	10
KMF 2-60(T)	405	235	405	215	10.5

Performance Curve

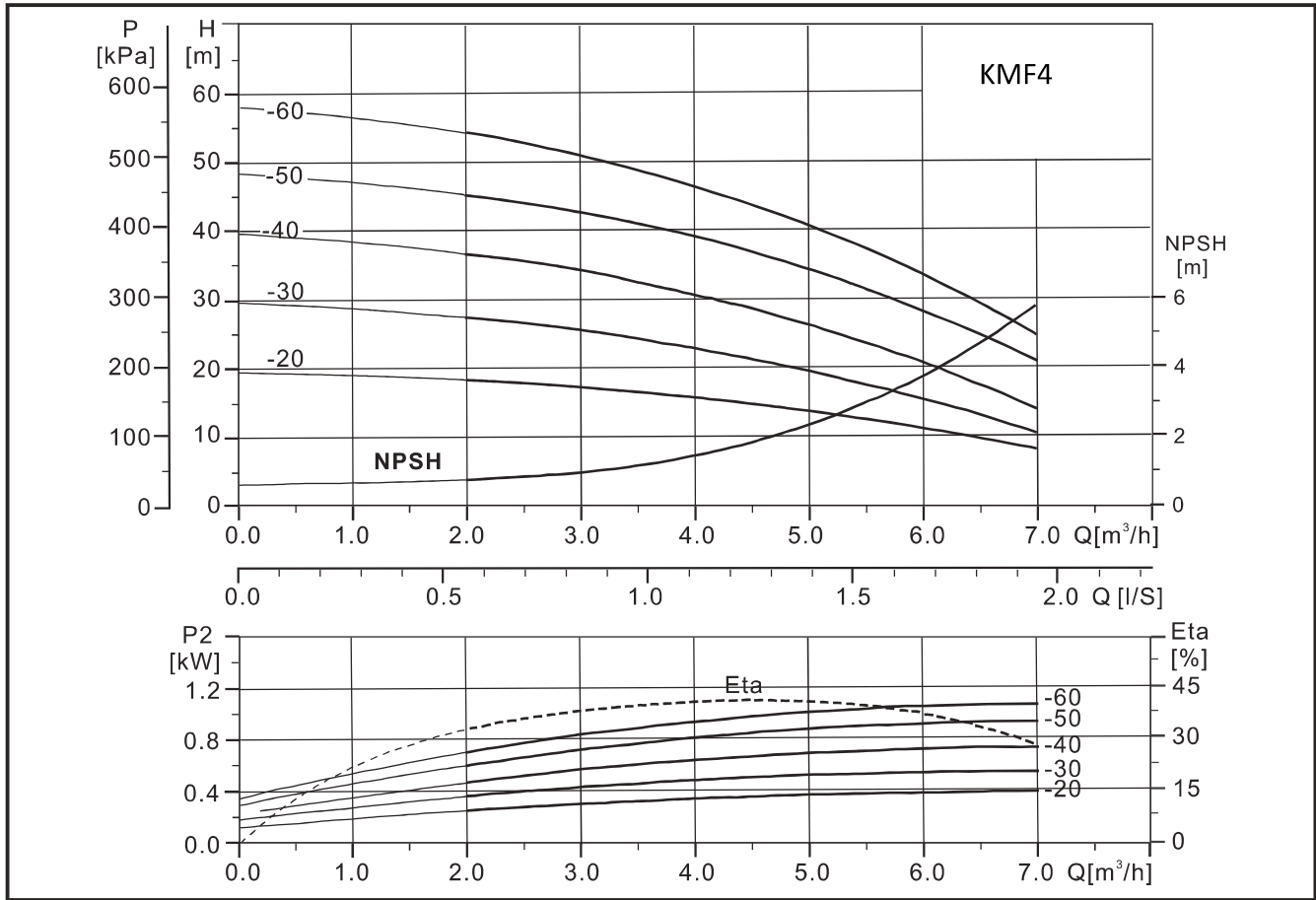

Performance Table

Modal		Driving Moter P ₂ (kW)	Q (m ³ /h)	H (m)						
Single Phase	Three Phase			2	3	4	5	6	7	
KMF 4-20	KMF 4-20T	0.55	H (m)	18	16	15	13	10	7	
KMF 4-30	KMF 4-30T	0.75		27	25	22	19	15	10	
KMF 4-40	KMF 4-40T	0.75		36	33	30	26	20	13	
KMF 4-50	KMF 4-50T	1		44	41	38	32	26	20	
KMF 4-60	KMF 4-60T	1.1		53	50	45	40	33	24	

Installation Sketch

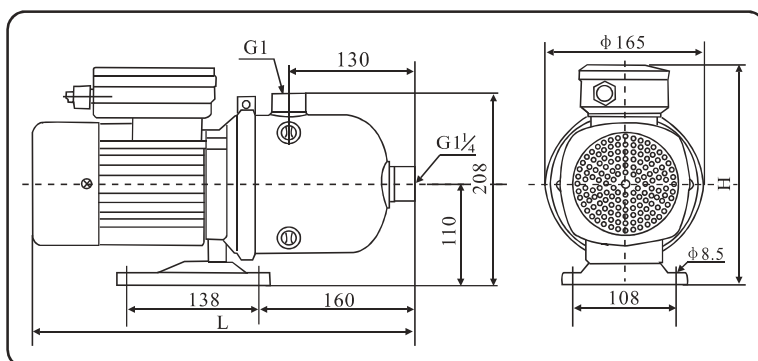

Model	Size(mm)				Weight (kg)
	Single-Phase		Three-Phase		
	L	H	L	H	
KMF 4-20(T)	405	235	405	215	10
KMF 4-30(T)	405	235	405	215	11
KMF 4-40(T)	405	235	405	215	11.5
KMF 4-50(T)	405	235	405	215	12
KMF 4-60(T)	405	235	405	215	12.5

Performance Curve

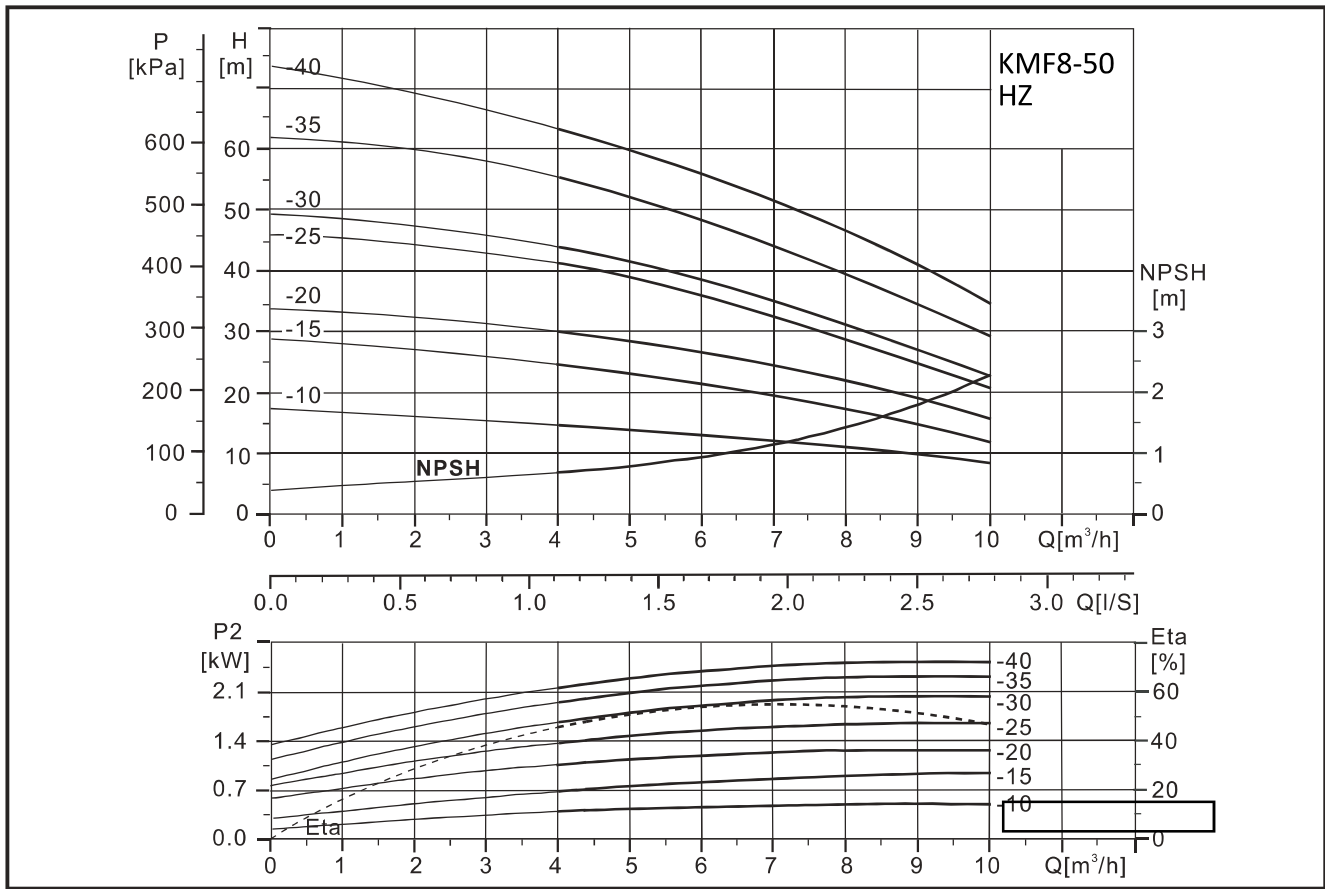

Performance Table

Modal		Driving Motor p ₂	Q (m ³ /h)	H (m)						
Single Phase	Three Phase			4	5	6	7	8	9	10
KMF 8-10	KMF 8-10T	0.55		15	14	13	12.5	12	9	8
KMF 8-15	KMF 8-15T	0.75		25	23	22	20	20	14	12
KMF 8-20	KMF 8-20T	1		32	29	27	25	24	21	17
KMF 8-25	KMF 8-25T	1.5		43	40	38	34	27	25	20
KMF 8-30	KMF 8-30T	1.85		45	43	40	35	30	29	22
KMF 8-35	KMF 8-35T	2.2		56	51	48	44	43	35	28
KMF 8-40	KMF 8-40T	2.2		65	57.5	57	50	48	42	34

Installation Sketch

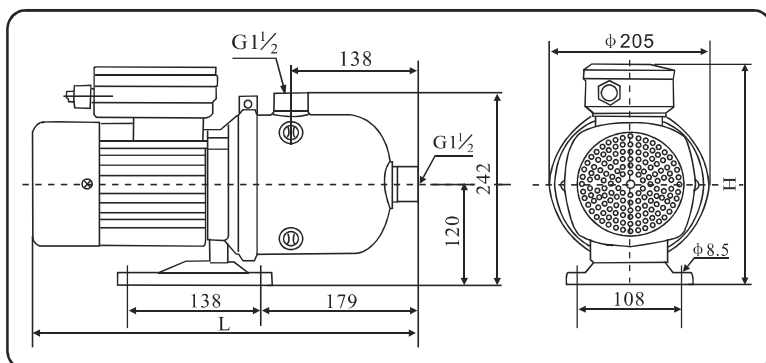

Model	Size(mm)				Weight (kg)
	Single-Phase		Three-Phase		
	L	H	L	H	
KMF 8-10(T)	425	245	425	215	10.5
KMF 8-15(T)	425	245	425	215	12
KMF 8-20(T)	425	250	425	215	14
KMF 8-25(T)	455	250	455	230	17
KMF 8-30(T)	495	265	455	230	21.5
KMF 8-35(T)	495	265	455	230	23
KMF 8-40(T)	495	265	495	235	24

Performance Curve

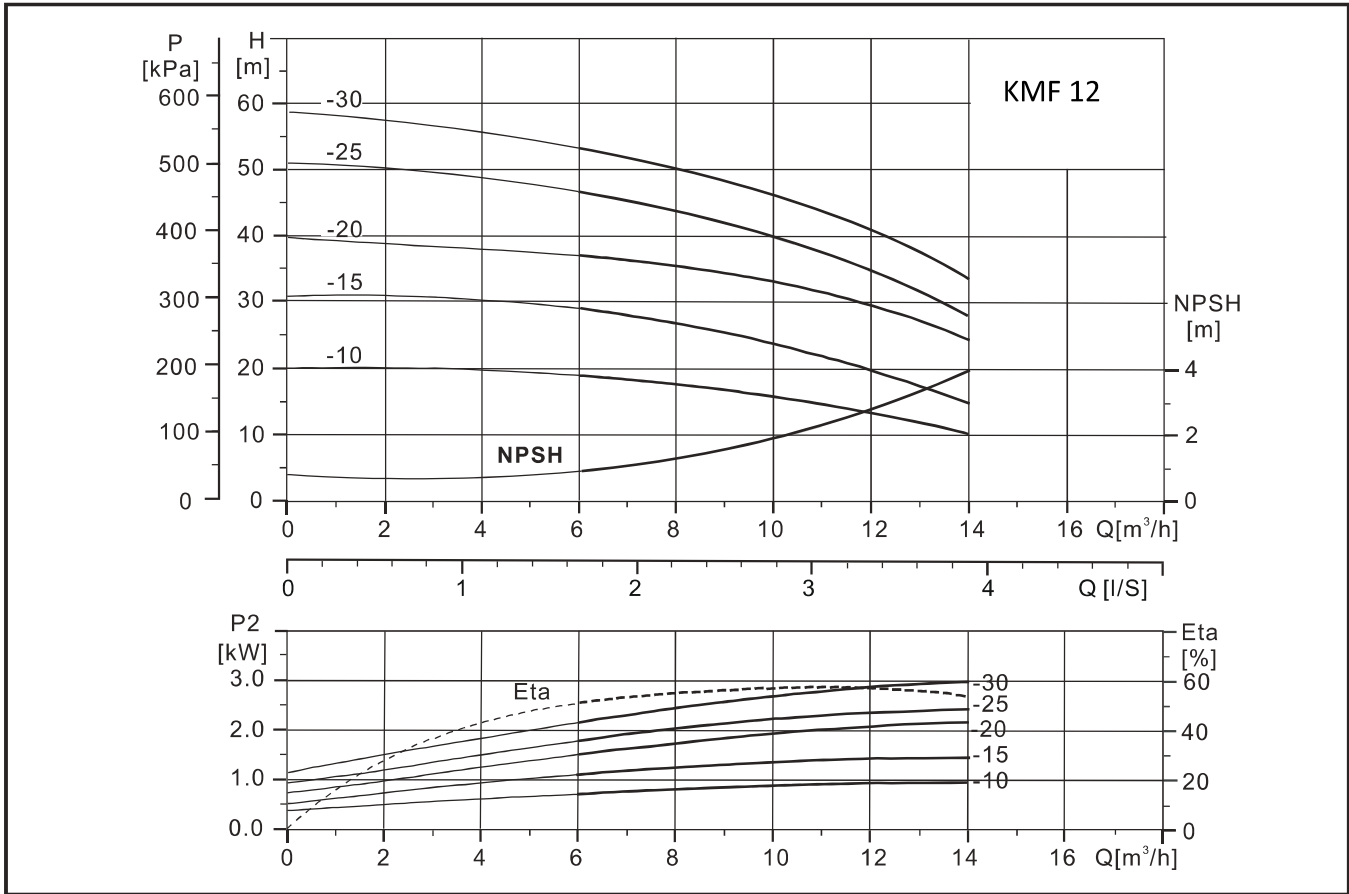

Performance Table

Modal		Driving Moter p ₂ (kW)	Q (m ³ /h)	H (m)									
Single Phase	Three Phase			6	7	8	9	10	11	12	13	14	
KMF 12-10	KMF 12-10T	1	H (m)	19	18	17.5	16	15.5	14	13.5	12	10.5	
KMF 12-10	KMF 12-10T	1.5		28	27	26	25	24	22	20	18	15	
KMF 12-10	KMF 12-10T	1.85		38	36	35	32	31	29	28	24	20	
KMF 12-10	KMF 12-10T	2.2		47	45	43	41.5	39	36	33.5	30.5	27	
	KMF 12-10T	3		53.5	52	50	47.5	45	42	39	35	30	

Installation Sketch

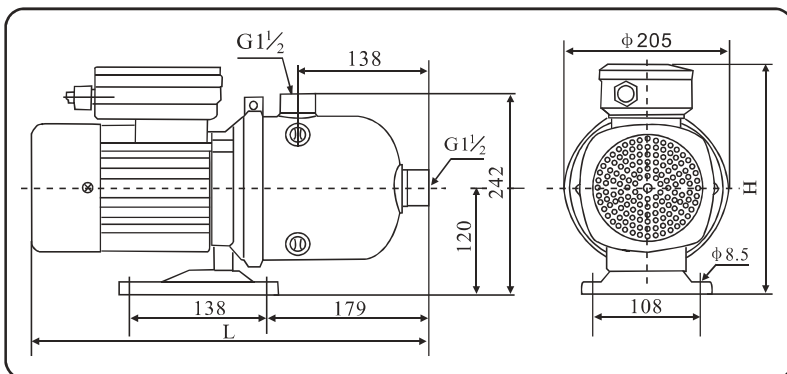

Model	Size(mm)				Weight (kg)
	Single-Phase		Three-Phase		
	L	H	L	H	
KMF 12-10(T)	425	245	225	220	12
KMF 12-15(T)	455	255	255	230	13.5
KMF 12-20(T)	495	265	255	230	21
KMF 12-125(T)	495	265	255	230	24
KMF 12-30T	-	-	515	235	27

Performance Curve

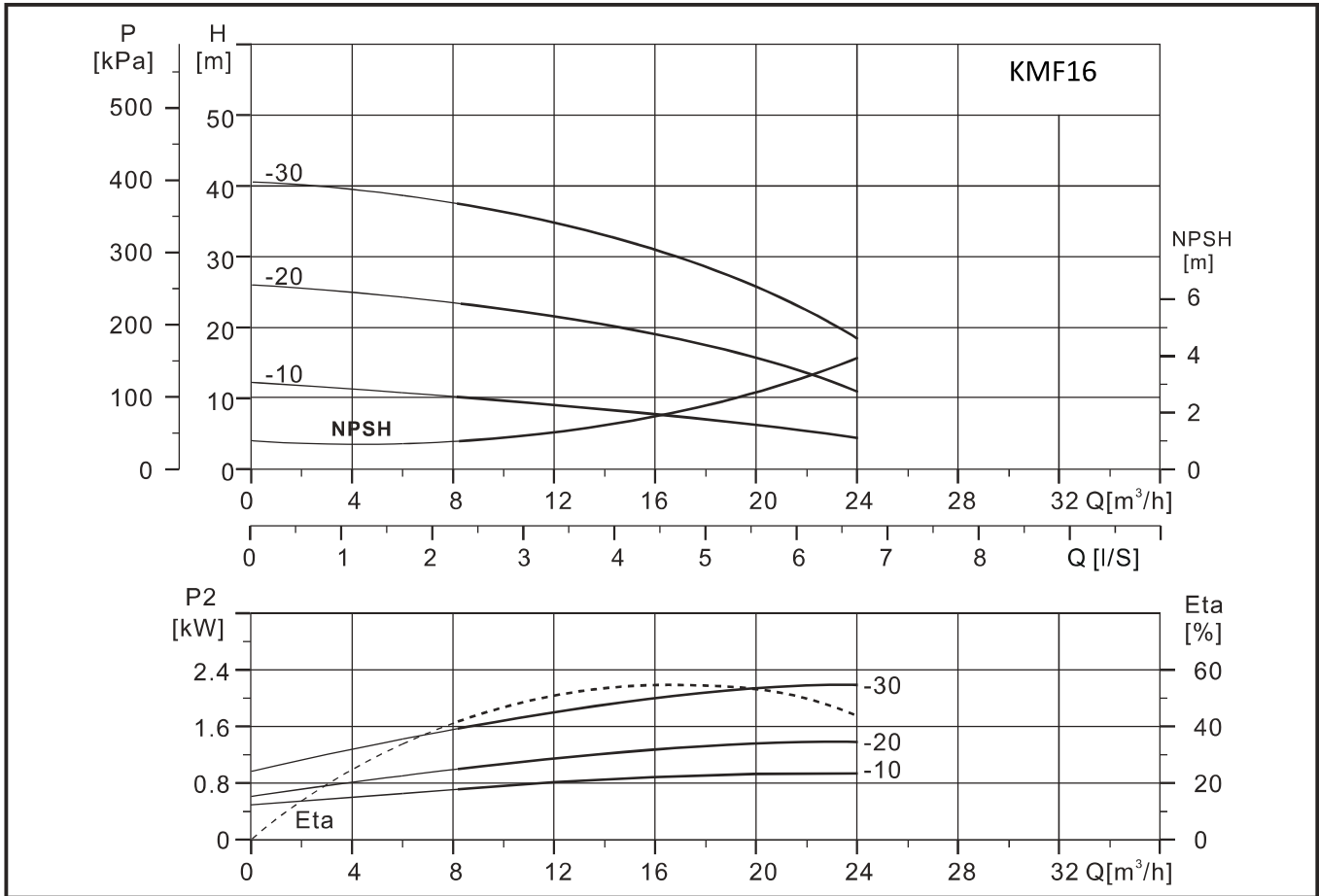

Performance Table

Modal		Driving Moter p ₂ (kW)	Q (m ³ /h)	H (m)											
Single Phase	Three Phase			8	10	12	14	16	18	20	22	24			
KMF 16-10	KMF 16-10T	1	H (m)	12	11.5	11	10.5	10	9	8	7	6			
KMF 16-20	KMF 16-20T	1.5		24	23	22	21	20	19	16	14	12			
KMF 16-30	KMF 16-30T	2.2		38	36	34	33	30	28	26	23	20			

Installation Sketch

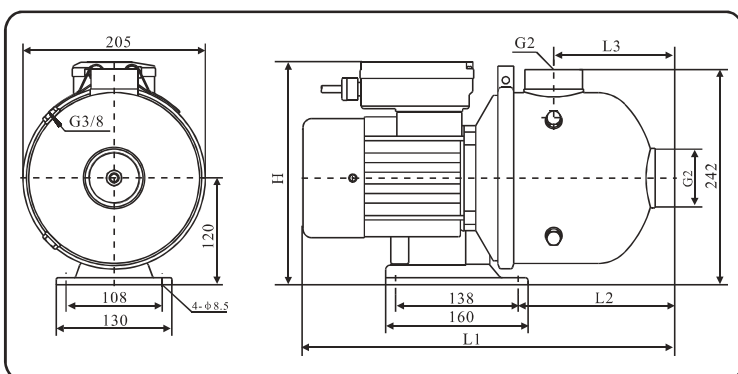

Model	Size(mm)								Weight (kg)
	Single-Phase				Three-Phase				
	L	L2	L3	H	L	L2	L3	H	
KMF 16-10(T)	425	175	136	245	425	175	136	222	13.5
KMF 16-20(T)	495	175	136	245	455	175	136	230	17
KMF 16-30(T)	535	201	162	265	535	201	162	235	23

Performance Curve

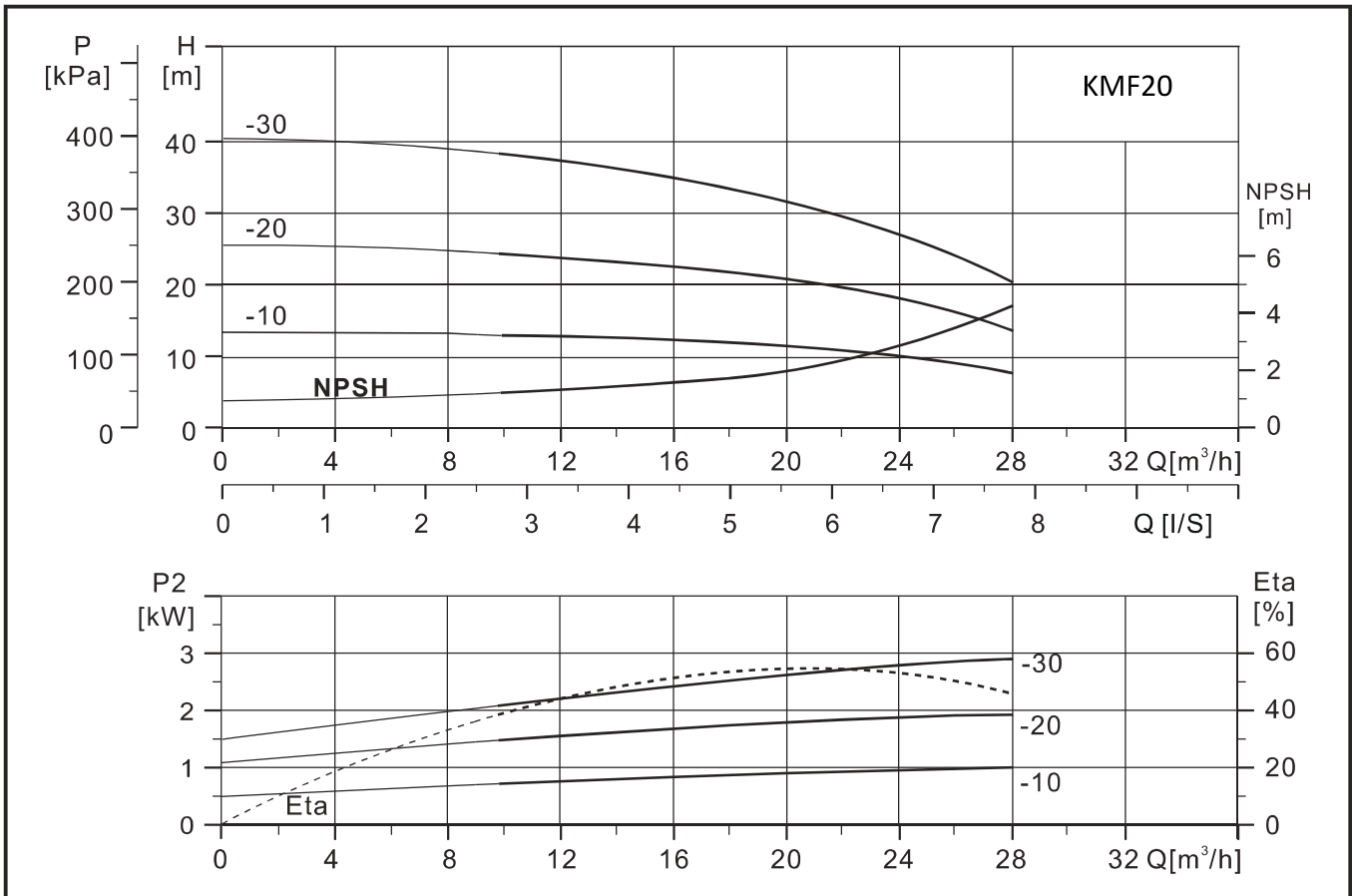

Performance Table

Model		Driving Moter p ₂ (kW)	Q (m ³ /h)	10	12	14	16	18	20	22	24	26	28
Single Phase	Three Phase			H (m)									
KMF 20-10	KMF 20-10T	1		13	12.5	12	11.5	11	10.5	10	9	8.5	7.5
KMF 20-20	KMF 20-20T	1.85		25	24	23	22	21	20	18	16	14	12
	KMF 20-30T	3		39	38	36	35	33	31.5	30	27	24	21

Installation Sketch

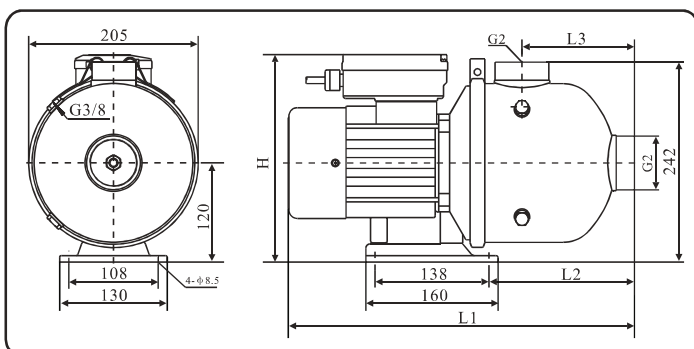

Model	Size(mm)								Weight (kg)
	Single-Phase				Three-Phase				
	L	L2	L3	H	L	L2	L3	H	
KMF 20-10(T)	425	176	136	245	425	175	136	220	20
KMF 20-20(T)	495	176	136	265	455	175	136	230	22
KMF 20-30T	-	-	-	-	535	201	162	235	25