

Product Details : KELI 30T ANALOG LOADCELL



FEATURES:

- Capacity: 5t to 50t
- Steel ball loading, strong restoration ability
- Easy complete installation, high weighing accuracy
- OIML C3 certificate
- Alloy Steel

APPLICATION:

- Truck scale
- Railway scale
- Blending scale and all kinds of weighing apparatus

Wiring Diagram

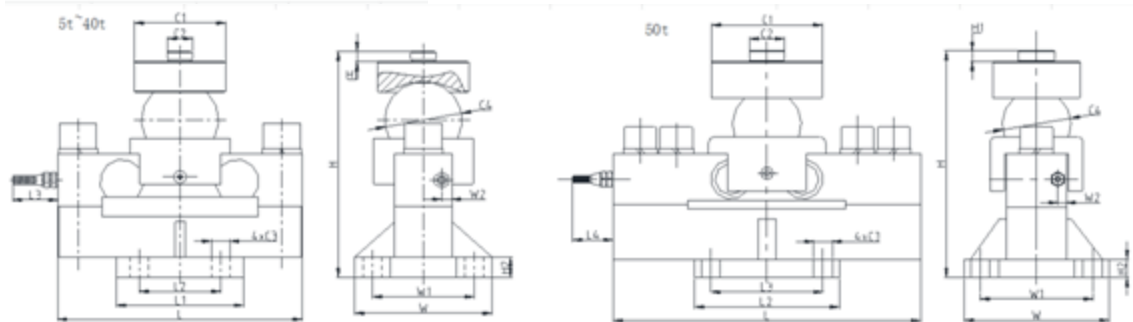
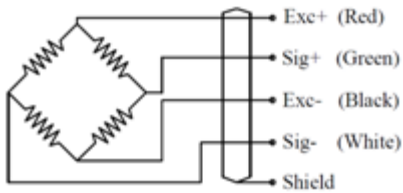

Outline Dimension:													
Rated capacity(t)	L	L1	L2	L3	W	W1	W2	H	H1	H2	C1	C2	C3
5	224	125	80	45	135	100	10	168.8	11	20	Φ68	Φ30	Φ18
10,15,20,25,30	240	125	80	45	135	100	10	223.5	11	20	Φ85~88	Φ30	Φ18

40	240	125	80	45	135	100	10	239.5	11	20	Φ88	Φ30	Φ18
50	340	160	124	45	160	124	10	260	11	20	Φ98	Φ40	Φ22

SPECIFICATION:	
Rated capacity: 5ton to 50ton	Operating temperature range: -30 to +70°C
Rated output: 2.0±0.002mv/v	Maximum safe overload: 150% OF R.C
Combined error: ±0.03% F.S	Ultimate safe overload: 200% OF R.C
Non-repeatability: ±0.02% F.S	Recommended Excitation: 10 to 12V DC
Non-linearity: ±0.02% F.S	Maximum Excitation: 15V DC
Hysteresis error: ±0.02% F.S	Environment protection: IP68
Zero balance: ±1% F.S	Input impedance: 750±10Ω
Creep error(30minutes): ±0.02% F.S	Output impedance: 702±3Ω; 703±5Ω(cable≥15m);
Temperature effect on zero: ±0.02% F.S	Insulation resistance at 50V DC: ≥5000MΩ
Temperature effect on output: ±0.02% F.S	Material: nickel-plated alloy steel;
Compensated temperature range: -10 to +40°C	Cable length: 5.2meter(5t);8meter(10t); 10meter(15t); 10/12meter(20t);12/16meter(25t~50t),diameter 6mm

NOTE : some specification may be diff. .