

(Model : Wireless Steel high temp Crane Scale)

Features

- â†— High-strength load cell
- â†— Steel chrome plated case
- â†— American standard bow shackle
- â†— American standard eye hook



Functions

Products Standard--GB/T11883-2002--Electronic crane scale
Accuracy Class--OIML
A/D transfer speed-- 50times/sec
Loadcell input Voltage--DC 5V
Sensor connection --4 - wire
Max. internal code-- 1,000,000yd
Nonlinearity-- <0.01%F.S
Digital Calibration--Using keyboard
Serial communication interface--N.A.
Data storage : Accoding to Serial No.& Art.No.store separately, total 2000 groups of records optional
Display : 192*64 matrix LCD(with backlight)
Temperature Range: Body -10--f-+50--f
Humility Range--85%
Battery Life in Single Charge : approx 10 to 12 hours
Frequency- 450MHz
Range of Remote Display : 20m without obstacle—will be less if any partition between scale and wireless display

Specification	
Accuracy class	OIML III
Tare range	100%F.S.
Radio frequency	450MHZ
Safe Overload	120%F.S.
Limited Load	400%F.S.
Overload alarm	100%F.S.
Battery	6V/4AH
Zero range	4%F.S.
Battery life	>100h

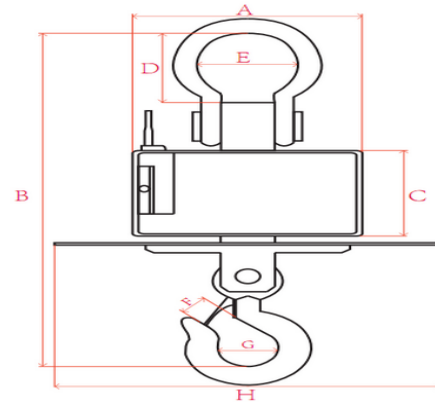

CAPACITY, ACCURACY ,SIZE AND WEIGHT :

Model	Max Capacity kg	Division kg	Number of divisions	Crane scale Size mm							Weight kg
				A	B	C	D	E	F	G	
OCS-3T	3000	1	3000	265	160	550	104	65	33	50	31
OCS-5T	5000	2	2500	265	160	640	115	84	55	65	31
OCS-10T	10000	5	2000	265	160	750	135	102	65	80	41
OCS-15T	15000	5	3000	265	190	810	188	116	65	80	62
OCS-20T	20000	10	2000	331	200	970	230	140	85	100	85
OCS-30T	30000	10	3000	331	200	1020	165	145	117	127	115
OCS-50T	50000	20	2500	420	317	1450	400	233	130	160	338

MOLTON IRON TEMP.	1000°C	1200°C	1400°C	1500°C
SAFE DISTANCE	1200mm	1500mm	1800mm	2000mm

Included Accessory



Battery (6V/4AH)



Adaptor