



SIMANDHAR TECHNOLOGY

MFG. BRAND:
SHRI SAI & SIMANDHAR



HEAT PROOF CRANE SCALE

MODEL : CRSFLP-H

Specifications:

- # capacity : 2T, 3T,5T,10T,15T
- # Die casting body.
- # Tare Range : 100% F.S.
- # Settling Time : 5-8s
- # Safe Overload : 125% F.S.
- # Limited Load : 150% F.S.
- # Overload alarm : 100% F.S.
- # Battery : 6v/4AH.
- # Battery Life : >80h
- # New circuit design, longer standby time and more stable.
- # Quality in one sensor design, weighing fast accurate and stable.
- # high quality sealed maintenance free rechargeable batteries, shock-resistant high- strength Aluminium alloy chassis.
- # stability : the perfect program, do not crash, do not hop.
- # U.S : Fashion appearance, Patented design.
- # Ultra bright led digital display, Character height 30mm / 5
- # operating Temperature : -10°C~40°C
- # Province : Handheld remote control, Convenience.



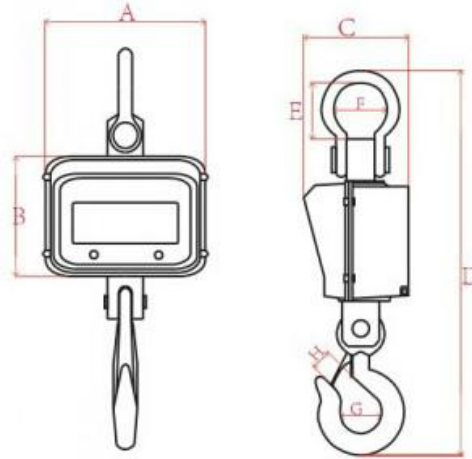

MODEL	MAX. CAPACITY (KG)	DIVISION (KG)	Dimensions								NET WEIGHT (KG)
			SIZE (MM)								
			A	B	C	D	E	F	G	H	
CRSFLP-H -2T	2000	500G	255	190	205	580	70	67	46	35	13.5
CRSFLP-H-3T	3000	500G	255	190	205	580	70	67	46	35	13.5
CRSFLP-H-5T	5000	1KG	255	190	205	680	88	73	60	45	18.5
CRSFLP-H-10T	10000	2KG	255	190	205	780	114	92	71	59	30
CRSFLP-H-15T	15000	5KG	255	190	205	830	120	97	77	65	36.5

MOLTON IRON TEMP.	1000°C	1200°C	1400°C	1500°C
SAFE DISTANCE	1200MM	1500MM	1800MM	2000MM

INCLUDE ACCESSORIES



Battery



Remote control



Adaptor