



## HEAT PROOF CRANE SCALE WITH WIRELESS PRINTER INDICATOR

### MODEL : CRSFLPWPI-H

#### Specifications:

- # capacity : 2T, 3T,5T,10T,15T
- # Die casting body.
- # Tare Range : 100% F.S.
- # Settling Time : 5-8s
- # Safe Overload : 125% F.S.
- # Limited Load : 150% F.S.
- # Overload alarm : 100% F.S.
- # Battery : 6v/4AH.
- # Battery Life : >80h
- # New circuit design, longer standby time and more stable.
- # Quality in one sensor design, weighing fast accurate and stable.
- # high quality sealed maintenance free rechargeable batteries, shock-resistant high- strength Aluminium alloy chassis.
- # stability : the perfect program, do not crash, do not hop.
- # U.S : Fashion appearance, Patented design.
- # Ultra bright led digital display, Character height 30mm / 5
- # operating Temperature : -10°C~40°C
- # Province : Handheld remote control, Convenience.



#### PRINTER FEATURES:-

1. Completely Customizable slip at customer side
2. 20 alphanumeric character for Header1
3. 20 alphanumeric character for header2
4. 20 alphanumeric character for footer
5. Selection of no of copy of each print
6. Select among 4 different print slips
7. 1000 Data Storeg Memory
8. Data output through usb pendrive.

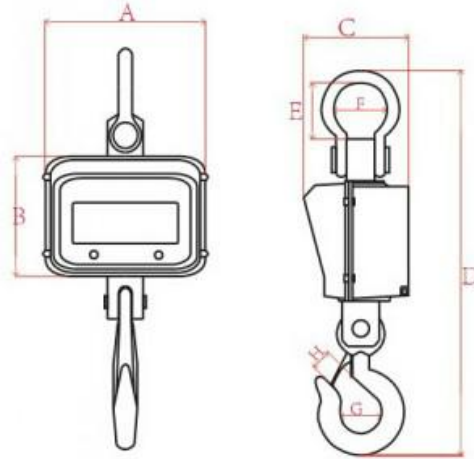

MODEL	MAX. CAPACITY (KG)	DIVISION (KG)	Dimensions								NET WEIGHT (KG)
			SIZE ( MM )								
			A	B	C	D	E	F	G	H	
CRSFLPWPI-H-2T	2000	500G	255	190	205	580	70	67	46	35	13.5
CRSFLPWPI-H-3T	3000	500G	255	190	205	580	70	67	46	35	13.5
CRSFLPWPI-H-5T	5000	1KG	255	190	205	680	88	73	60	45	18.5
CRSFLPWPI-H-10T	10000	2KG	255	190	205	780	114	92	71	59	30
CRSFLPWPI-H-15T	15000	5KG	255	190	205	830	120	97	77	65	36.5

MOLTON IRON TEMP.	1000°C	1200°C	1400°C	1500°C
SAFE DISTANCE	1200MM	1500MM	1800MM	2000MM

### INCLUDE ACCESSORIES



Battery



Remote control



Adaptor



**SIMANDHAR TECHNOLOGY**

MFG. BRAND:  
SHRI SAI & SIMANDHAR



• Currency Counting Machine • Weighing Scale • CCTV Camera System



+91 94260 31593, +91 70165 39660

[www.digitalweigh.web.in](http://www.digitalweigh.web.in)

[simandhartechnology2009@gmail.com](mailto:simandhartechnology2009@gmail.com)

59/B, SUMEL-5, NR.CHAMUNDA BRIDGE, CHAMANPURA CIRCLE, ASARWA , AHMEDABAD - 380016.