

HEAT PROOF CRANE SCLAE

MODEL : CRSFLPWI

- ◆ High-strength steel case (RED font)
- ◆ Accuracy class : OIML III
- ◆ Die cast body
- ◆ Integrated sensor design
- ◆ American standard eye hook
- ◆ LED display, digital height 45mm
- ◆ Build-in rechargeable battery
- ◆ Remote control
- ◆ Capacity : 20T, 30T, 50T
- ◆ Colour : Blue / Any
- ◆ Tare range : 100% F.S
- ◆ Settling Time : 5-8s
- ◆ Safe Overload : 125%F.S.
- ◆ Limited Load : 400% F.S.
- ◆ Overload alarm : 100% F.S
- ◆ Battery : 6V/12AH
- ◆ Work Temperature : -10°C~40°C
- ◆ Battery life : >80h

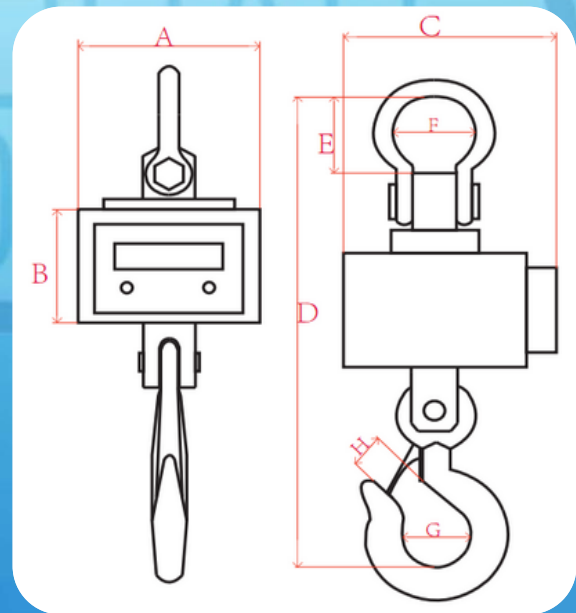
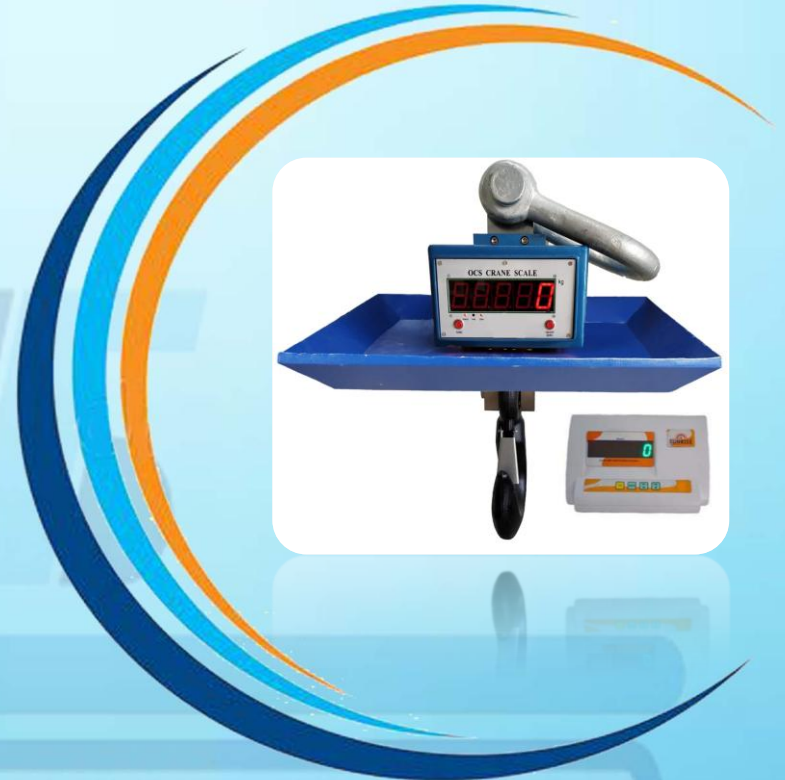

Model	Max. capacity kg	Division kg	Crane scale size mm.								Weight kg
			A	B	C	D	E	F	G	H	
CRSFLPWI-20T	20000	10	305	200	310	840	104	124	105	80	85
CRSFLPWI-30T	30000	10	308	200	310	1002	106	245	130	280	115
CRSFLPWI-50T	50000	20	420	317	420	1450	400	233	165	133	338

MOLTON IRON TEMP.	1000°C	1200°C	1400°C	1500°C
SAFE DISTANCE	1200MM	1500MM	1800MM	2000MM

Functions	
Zero	Digital Calibration
Tare	3-point Linearity Correction
Hold	lb/kg Switch
Battery Supervision	Division Switch
Overload Alarm/ Record	Gravity Acceleration Set

INCLUDE ACCESSORIES



Battery

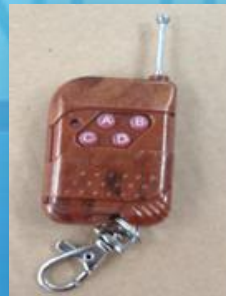

Remote control



Adaptor

+91 9426031593 , +91 7016539660

simandhartechnology2009@gmail.com

59/B Sumel-5 Business Park , Chamanpura
Asarwa , Ahmedabad-380016



AN ISO 9001 : 2015

