

**FITZER**  
**INCORPORATION**

# Shell & Tube Condenser & Evaporator



# Shell & Tube Condenser & Evaporator

## Index

1	Introduction	1
2	Vision & Mission	1
3	What is a Heat Ex-changer	1
4	Shell & Tube Condenser	3
5	Shell & Tube Evaporator	7
6	Shell & Tube Condenser (Drawing & Dimension details)	10
7	Shell & Tube Evaporator (Drawing & Dimension details)	15
8	Shell In Shell Evaporator / Oil cooler / Inter cooler / After cooler	20
9	Refrigerant & Water Connection	21

**FITZER** is an Indian based manufacturing engineering company that designs, manufactures & offers reliable, cost effective industrial engineering products mainly

Heat Ex-changer's for Air Conditioning & Refrigeration industries and Water / Air / Gas / Oil cooling applications since 1981.

**Vision & Mission**

**FITZER Vision** is to become a leading reputed manufacturer & provider of Shell & Tube Condensers & Evaporators in Indian market with the best possible design to deliver efficient performance by using better designed & developed material & quality workmanship at reasonable cost.

**FITZER Mission** is to expand and continually improve utilizing quality practices and employee involvement to manufacture Heat Ex-changer's for the Refrigeration industry, both in the domestic and international markets, that result in customer and employee satisfaction.

**What is a Heat Ex-changer**

A heat ex-changer is an equipment that is used to transfer heat between two different fluids without mixing with each other. Heat ex-changer's are used in both cooling and heating processes. Heat Ex-changer's are very important in any Air Conditioning & Refrigeration System.

Heat Ex-changer plays a vital role in any AC & R System. With perfect designing & selection of proper material, HE's shall save the energy & environment. **FITZER** is a team of professional engineers, designing with technical calculation & selection of suitable material to deliver best performance and result.

**Products**

- Shell & Tube type Water Cooled Condenser
- Shell & Tube type Evaporator (U-Bundle design & Straight Tube design)
- Shell In Shell type Evaporator
- Oil Coolers
- Inter / After Coolers

**Condenser Model Nomenclature**

B	CD	XXX	X	XX
	Condenser	Model No.	Length Variations S   X M   Y W   Z	NS – Non Standard SW – Sea Water HP – High Pressure

**Evaporator Model Nomenclature**

B	CH	XXX	X	XX
	Chiller	Model No.	Circuit S – Single D – Double T – Triple Q – Four	NS – Non Standard BT – Brine Temperature SS04 – SS304 Construction SS16 – SS316 Construction



**FITZER** shell and tube condensers represent the flawless solution for all the application where HFC condensation is required such as Water cooled chillers, Condensing units and heat pumps for industrial cooling & air conditioning in combination with

different types of processes and Commercial refrigeration plants with water cooled condensation. On-board or all the other applications where sea, lake or river water is available.



Air Conditioning



Industrial & Process Cooling Refrigeration



Marine Refrigeration



Commercial Refrigeration

## An Extensive Range

**FITZER** Shell & Tube Condenser production includes a various range of condensers providing easy solutions for Air conditioning, Refrigeration and Cooling application including marine applications.

**FITZER** condensers have been carefully optimized for the most used HCFC / HFC refrigerants.

- All condenser models are easily openable for inspection and maintenance purposes.
- Standard models attain condensation capacity ranging from 3 to 900 kW. Also higher capacity models shall be offered on request.
- Multi circuit (2/3/4) condensers are also available on request for multi-circuit chillers.
- Customized length with different MOC can be designed for specific application as per request.

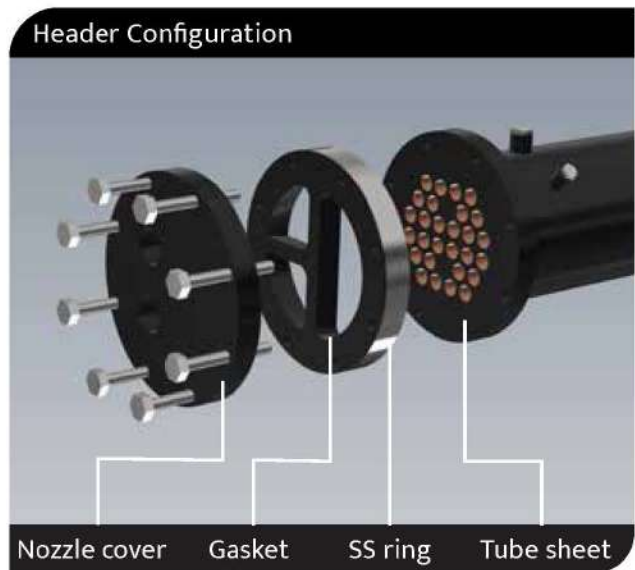

## Salient Features & Benefits

- 1) **High Performance** due to exceptionally designed integrally finned (enhancing Heat Transfer area) & inner grooved (for better performance due to turbulence on water side path) Copper / Cupro-Nickle tubes and specific tube geometry pattern.
- 2) **Low Ref. Gas volume requirement** due to compact Size, less space consumption & less weight.
- 3) **Wide model range** for easy and ideal selection.
- 4) **Optimized for Various Refrigerant Gas** – R-22 / R-134a / R- 404a / R-407c / R-410a (Ammonia Ref. Gas shall be available on request).
- 5) **2 passes & 4 passes** version (3 pass available on request).
- 6) **Easily open-able** for inspection & maintenance / cleaning.
- 7) **Solutions for applications with fresh water & sea water.**
- 8) **All the material are thoroughly inspected, tested & manufactured as per standard pressure vessel codes.** Specific third party inspections / approvals available on request.
- 9) **All condensers are pressure & leak tested** before delivery ensuring top quality products.
- 10) **Extra care taken for proper Internal & external cleaning** to run system smoothly.
- 11) **Synthetic enamel spray painting** with prior primer coating to make product more attractive.
- 12) **Proper packing** make equipment reach your place safely.



## Manufacturing Quality & Efficient Component Design

Models designed for fresh water application has following major components.

- Shell : Carbon steel
- Tube sheet : Carbon steel
- Tubes : Copper (Integrally finned & Inner-grooved)
- End Covers : Carbon steel
- Gasket : Thermopolymer compound
- Hardware : Graded Alloy Steel as per pressure requirements (High Tensile)

**FITZER** Condensers are also available in stainless steel execution (AISI 304 / 316 / 316L) for corrosive atmosphere.

**FITZER** shell and tube Condensers have a high level of mechanical strength and resistance to vibration and corrosion.

All machining, drilling operations are carried out with CNC/VMC for accuracy to meet required quality. The material selection is done not only to achieve

Heat Ex-change target, but also to meet pressure needs due to years of intensive usage.

All the carbon steel components are sand blasted and cleaned thoroughly including the internal wall of the shell before assembly. Also, tube sheets & end covers are completely zinc-coated to avoid corrosion and rusting. Provision of sight glass on shell side is available as an option.

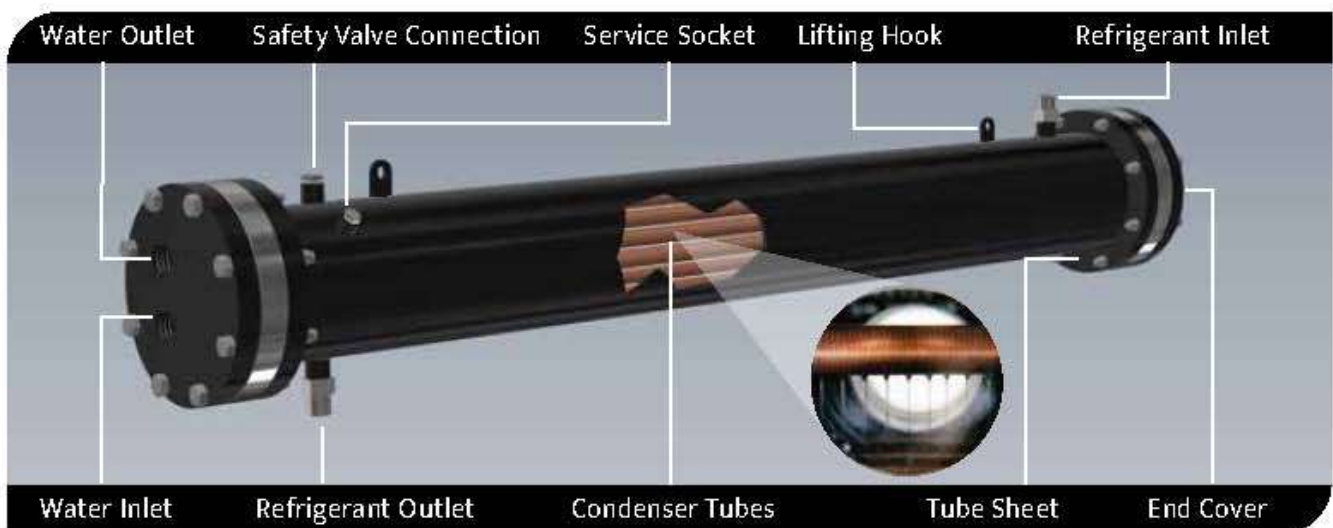

## Marine application (Sea Water Condensers)

Different condenser models are available ranging from 15 kW to 900 kW, for on board marine applications and for all the other installations where it is mandatory to use the sea as a natural source of cooling water.

Marine models are equipped with the following components:

- Shell : Carbon steel
- Tube sheets : AISI 316L stainless steel
- Tubes : Integrally finned Cu/Ni tubes ( 90/10% or 70/30%)
- Covers : AISI 316L stainless steel
- Gasket : Thermopolymer compound

Marine units are provided with interchangeable sacrificing anodes made of special metal to protect equipment.



## Quality & Approvals

The working limits are defined by the design pressure (i. e. the maximum working pressure) and the working temperature range. These limits depend on the pressure vessel approval required. **FITZER** condensers are available as a standard with the most diffused pressure vessel approvals. On request marine or other specific approvals are available.

## Testing Pressure Limits

**FITZER** shell and tube condensers are manufactured in accordance internal quality and Each and every unit goes through an individual pressure / leak test as specified by the relevant authority and in accordance with **FITZER** internal quality testing procedures.

Nominal Data	Unit	FITZER (Self Inspected)	CE (PED 97/23 EC)	ASME
Design pressure refrigerant side	bar	20	30	30
Test pressure refrigerant side	bar	23	43	45
Design pressure water side	bar	5	10	10.3
Test pressure water side	bar	10	15	15.5
Design temperature range	°C.	(-) 10°C / (+) 90°C	(-) 10°C / (+) 90°C	(-) 10°C / (+) 90°C

## Versions

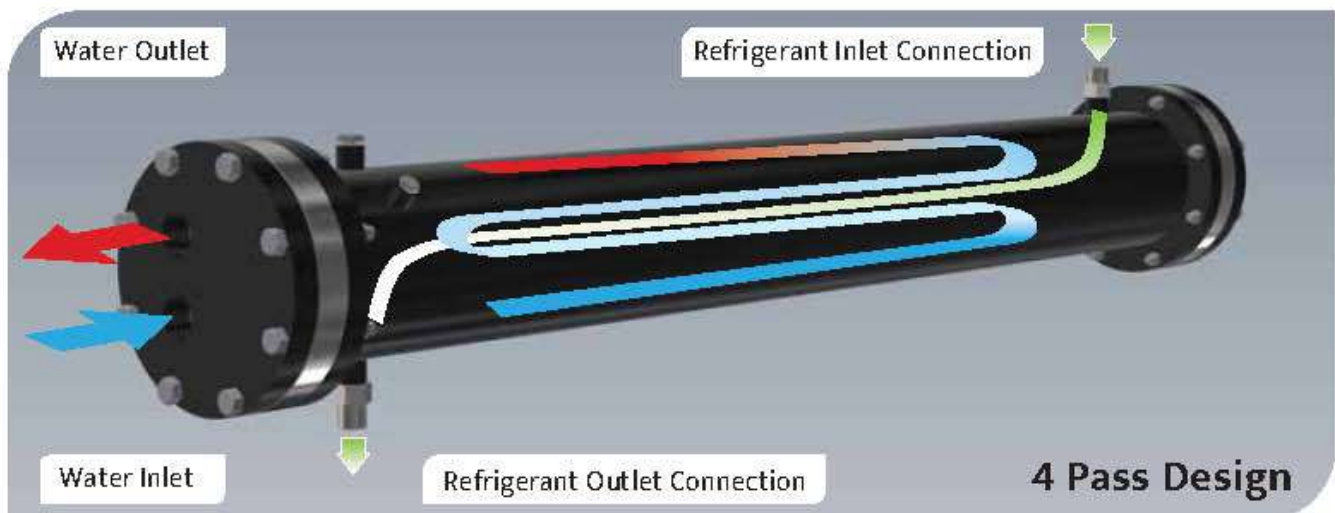
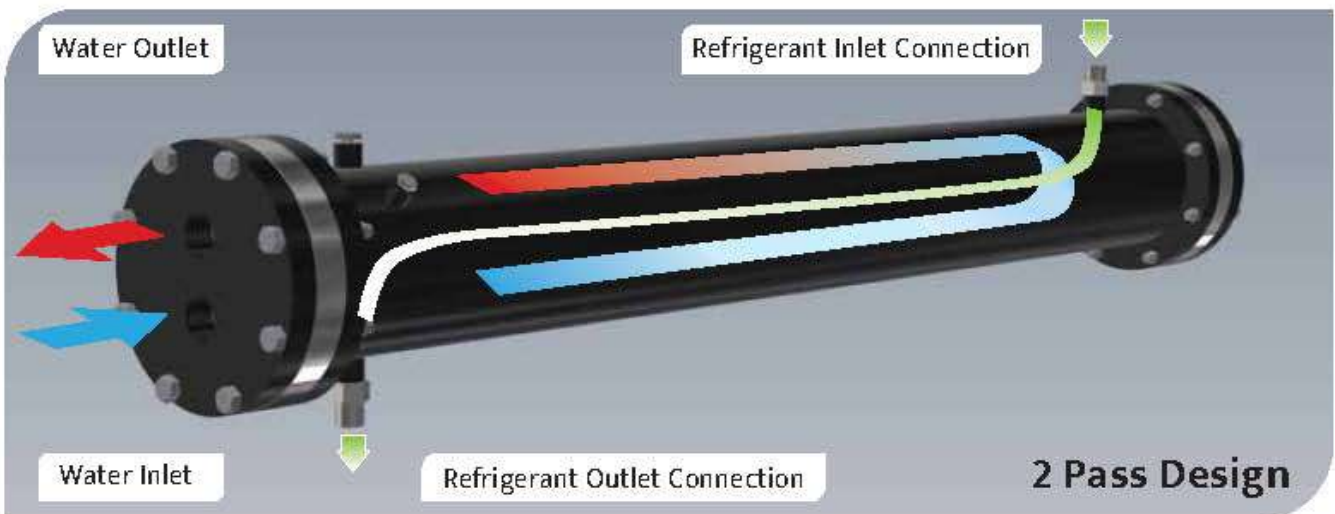



## Best Performance with preventive maintenance

Shell and tube condensers are often used with impure / hard water for heavy duty applications. It is a thrilling challenge for a designed product in order to have a long working life and efficient performance. In these cases, periodical cleaning is required in order to

keep the heat exchanger's performances unchanged over a period of time. **FITZER** fresh and sea water condensers ensure easy opening for inspection, cleaning and maintenance purposes.

The nominal performances have been calculated on the basis of an Fouling Factor equal to 0.000043 m<sup>2</sup>K/W (0.0005 h m<sup>2</sup>K/kcal)

$v > 1.2 \text{ m/s}$	Normal city Water Treated tower water Clean river water Sea Water	FF 0.000086 m <sup>2</sup> K/W
$v > 1.2 \text{ m/s}$	City lime water Normal tower water Brine	FF 0.000172 m <sup>2</sup> K/W
$v > 1.2 \text{ m/s}$	Tower lime water Muddy water	FF 0.000344 m <sup>2</sup> K/W



## Variation available in Connections

### Refrigerant side :

- Coupling Connections (NPT)
- Rotolock Connections
- Bush Connections
- Pipe Connections

Reference page no : 21 & 22

### Water Side :

- Threaded Connections (BSP)
- Pipe connections
- Flange Connections
- Victaulic Connections

## Supports / Mountings

### Weldable Mounting bracket :

**FITZER** Condenser can be provided with supports welded to the shell.

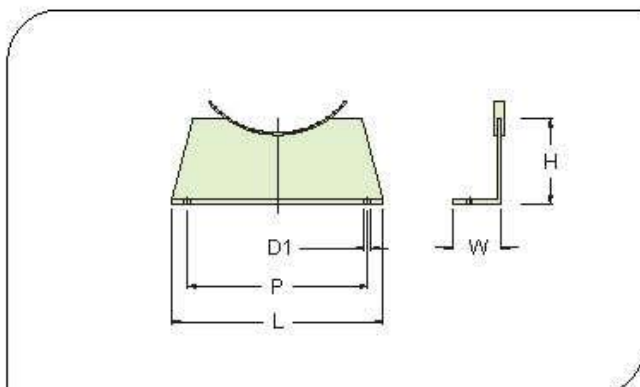

### "U" Clamp Mounting bracket :

Universal "U" Clamp brackets are easily movable across the length & positioned as per convenience during the installation with ease and flexibility.

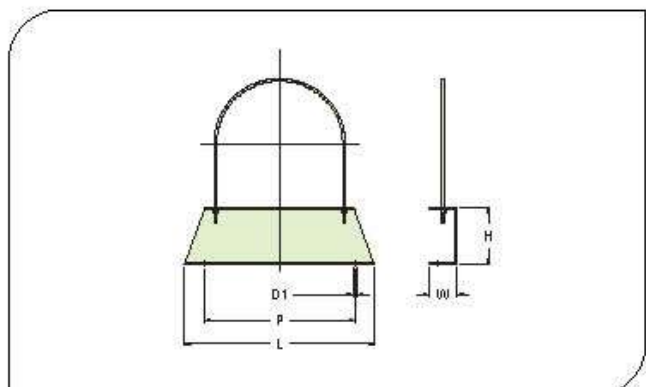

\* Illustrated in technical data pages



## Excellence and Flexibility in performance

**FITZER** BCH series of shell and tube evaporators with "U" Bundle design has remarkable technological evolution of a generation of heat ex-changers in the air conditioning and refrigeration applications.

The models of the series ensure cooling capacities from 5 kW to 1000 kW at nominal conditions. BCH series have been efficiently designed with multiple variations from 1 to 4 independent cooling circuits.

Also to comfort customers on positioning of Evaporator, BCH series has come up with more than 3 different types of connections (Female Threaded Coupling, Flange Connections and Victaulic Connections) depending on the customer's requirement and

3 different positions of the water connections (Left side, Right side and Top Side). Our standard models are designed with Flange connection on Top side.

**FITZER** evaporators have been optimized for the most used HFC / HCFC refrigerants. Adoption of grooved copper tubes with high efficiency allows to exalt performances increasing the cooling capacities of evaporators. This performance improvement can be translated into optimizing the cooling system not only with R22 but also with the other refrigerants. Particular attention has been paid to the design and working of evaporators. Suitable for various refrigerant Gases - R-22 | R-134a | R-404a | R - 407c | R - 410a.

## Salient features & Benefits

- 1) Exalted performances with minimum footprint, thanks to new high efficiency tubes and design.
- 2) Inner grooved tubes are designed to ensure safe flow which results in faster evaporation & moves ahead with turbulence delivering best output.
- 3) Design to ensure a safe flow for the most viscous lubricant oils.
- 4) Reduced pressure drop on water side.
- 5) All internal parts / construction are with non corrosive material resulting long life of equipment.
- 6) Multiple option for Refrigerant & Water connection.
- 7) 3 Different position of water connection are available to suit your requirement.
- 8) Stainless steel versions available on request.
- 9) Reduced length versions available on request.

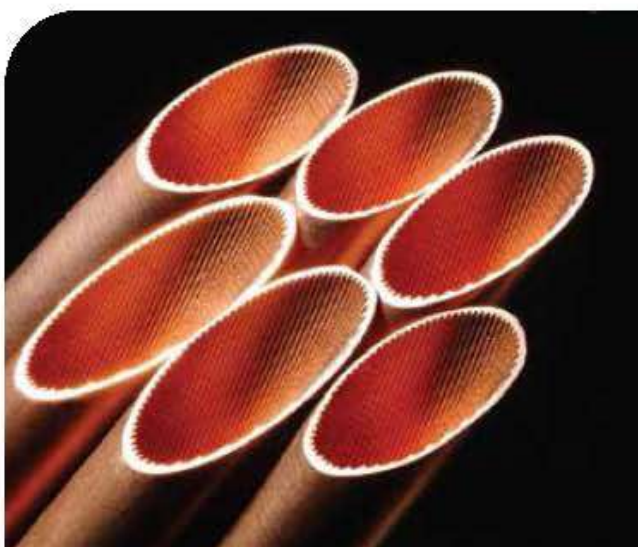

Copper tube (Inner Grooved)



Tube finishing

## Manufacturing Quality & Efficient Component Design

Models designed for fresh water applications use the following components.

- Shell : Carbon steel
- Tube sheet : Carbon steel
- Tubes : Copper (Inner-grooved)
- End Covers : Carbon steel
- Gasket : Thermopolymer compound
- Baffle : Engineering plastic (Non corrosive)
- Hardware : Graded Alloy Steel as per pressure requirements (High Tensile)

**FITZER** evaporators are also available in stainless steel execution (AISI 304 / 316 / 316L) following the requests. All the carbon steel components are sand blasted and cleaned thoroughly including the

internal wall of the shell before assembly. Also, tube sheets & end covers are completely zinc-coated to avoid corrosion and rusting.

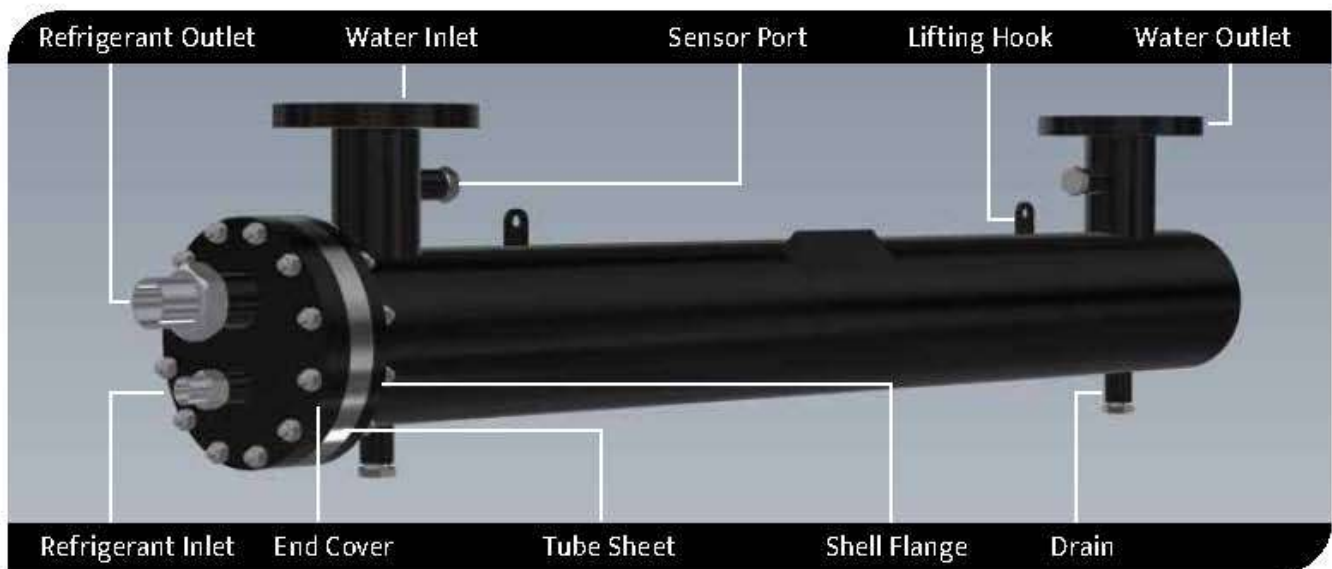

## Perfection in construction

**FITZER** shell and tube evaporators has a high level of mechanical strength and resistance to vibration and corrosion.

- All machining, drilling operations are carried out with CNC/VMC for accuracy to meet required quality.
- The “U” Bundle design of the tube allows the thermal expansion between tubes and the shell avoiding any tension.
- The “U” Bundle design allows customer to remove the tube bundle from the shell for inspection or maintenance.
- The “U” Bundle design allows customer to rotate the shell in order to change the water connection in any direction.
- The material selection is linked not only to heat exchange targets, but also to pressure design needs due to years of intensive usage.





## Quality & Approvals

Quality is offer the widest range of pressure vessel approvals. following the process indicated by the **FITZER** standard.

Each **FITZER** evaporator undergoes following tests :  
 - Pressure test refrigerant side with dry Nitrogen and water side hydraulically at the pressure values and :

- Multi circuits are tested & checked against internal by pass and leakage.
- After tests, the refrigerant circuit is purged & cleaned thoroughly.

Nominal Data	Unit	FITZER (Self Inspected)		CE (PED 97/23 EC)		ASME
		STD	BT	STD	BT	
Design pressure refrigerant side	bar	20	20	29	21	15.5
Test pressure refrigerant side	bar	23	23	41.5	30	17
Design pressure water side	bar	5	5	16	16	10
Test pressure water side	bar	10	10	22.8	15	11
Design temperature range	°C.	(-)10/(+)90	(-)40/(+)50	(-)10/(+)90	(-)40/(+)50	(-) 10°C / (+) 90°C

## Variation available in Connections

### Refrigerant Side :

- Bush Connections
- Roto-lock Connections
- Pipe Connections

Reference page no : 21 & 22

### Water Side :

- Female BSP threaded Coupling Connections
- Flange Connections – ASA #150
- Victaulic Connections

## Supports / Mountings

### Weldable Mounting bracket :

**FITZER** evaporator can be provided with supports welded to the shell.

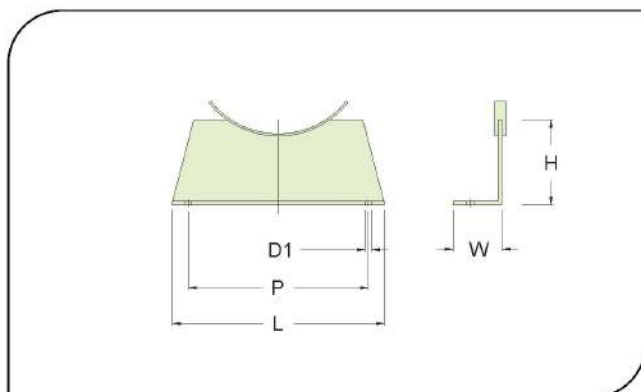

### “U” Clamp Mounting bracket :

Universal “U” Clamp brackets are easily movable across the length & positioned as per convenience during the installation with ease and flexibility.

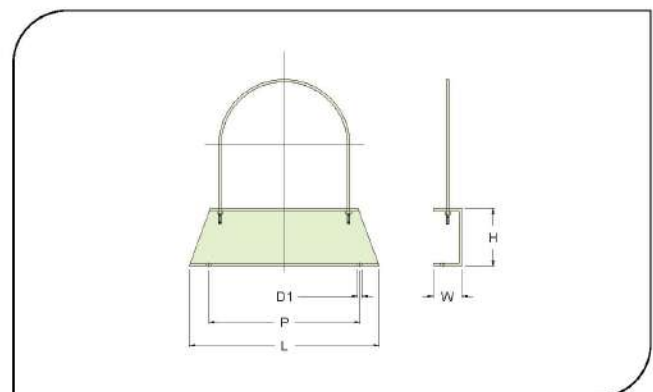

\* Illustrated in technical data pages

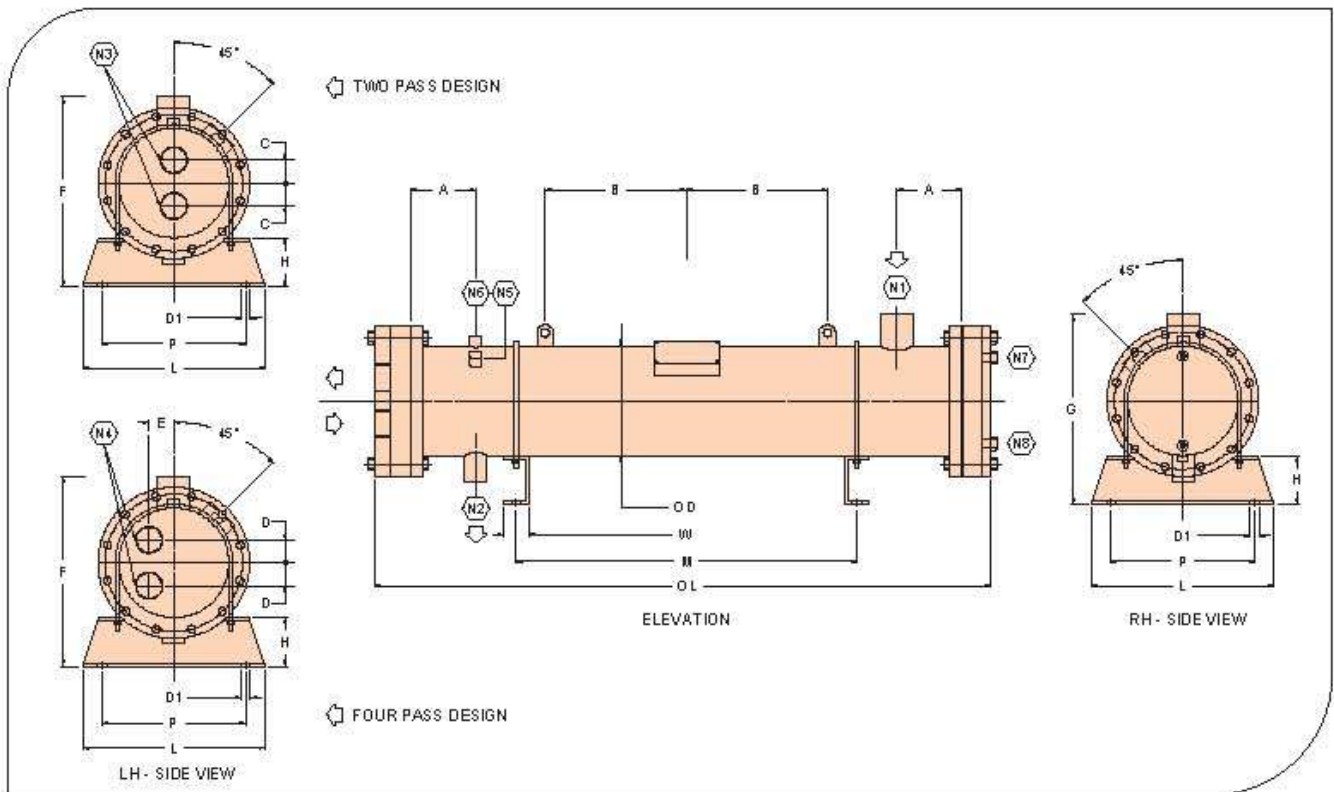

MODEL			BCD 08	BCD 12	BCD 15	BCD 35	BCD 45	BCD 60	BCD 80	BCD 100	BCD 120	BCD 145
DETAILS	SIGN	UNIT										
Dimension	OD	mm	140	140	140	168	168	168	168	168	168	168
	OL	mm	760	760	760	800	800	800	800	1500	1500	1500
	A	mm	100	100	100	100	100	100	100	100	100	100
	B	mm	130	130	130	130	130	130	130	480	480	480
	C	mm	35	35	35	45	45	45	45	45	45	45
	D	mm	32	32	32	35	35	35	35	35	35	35
	E	mm	28	28	28	35	35	35	35	35	35	35
	F	mm	275	275	275	328	328	328	328	333	333	333
Mounting Bracket	D1	mm	14	14	14	14	14	14	14	14	14	14
	P	mm	200	200	200	220	220	220	220	220	220	220
	L	mm	250	250	250	280	280	280	280	280	280	280
	W	mm	38	38	38	38	38	38	38	38	38	38
	M	mm	380	380	380	380	380	380	380	700	700	700
	H	mm	75	75	75	75	75	75	75	75	75	75
Connection	N1	-	RC 16	RC 16	RC 16	RC 28	RC 28	RC 28	RC 28	RC 35	RC 35	RC 35
	N2	-	RC 13	RC 13	RC 13	RC 22	RC 22	RC 22	RC 22	RC 22	RC 22	RC 22
	N3	-	TC 25	TC 25	TC 25	TC 50	TC 50	TC 50	TC 50	TC 50	TC 50	TC 50
	N4	-	TC 25	TC 25	TC 25	TC 40	TC 40	TC 40	TC 40	TC 40	TC 40	TC 40
	N5	In-NPT	1/4	1/4	1/4	1/4	1/4	1/4	1/4	1/4	1/4	1/4
	N6	In-NPT	3/8	3/8	3/8	3/8	3/8	3/8	3/8	3/8	3/8	3/8
	N7	In-NPT	3/8	3/8	3/8	3/8	3/8	3/8	3/8	3/8	3/8	3/8
	N8	In-NPT	3/8	3/8	3/8	3/8	3/8	3/8	3/8	3/8	3/8	3/8
Volumes	V-Ref	dm <sup>3</sup>	7.4	6.8	6.5	10.3	10	9.1	8.5	21.1	19.3	18.7
	V-H2O	dm <sup>3</sup>	1.1	1.7	2.1	2.3	2.6	3.5	4.1	5.3	7.1	7.7
Weight	W	Kg	42	44	45	51	52	53	55	70	75	77

- N1 Refrigerant Inlet
- N2 Refrigerant Outlet
- N3 Water Inlet/Outlet (2 Pass)
- N4 Water Inlet/Outlet (4 Pass)

- N5 Service Socket
- N6 Safety Valve Connection
- N7 Vent Connection
- N8 Water Drain Port

- OD Outer Diameter
- OL Overall Length
- V-Ref Refrigerant Volume
- V-H2O Water Volume



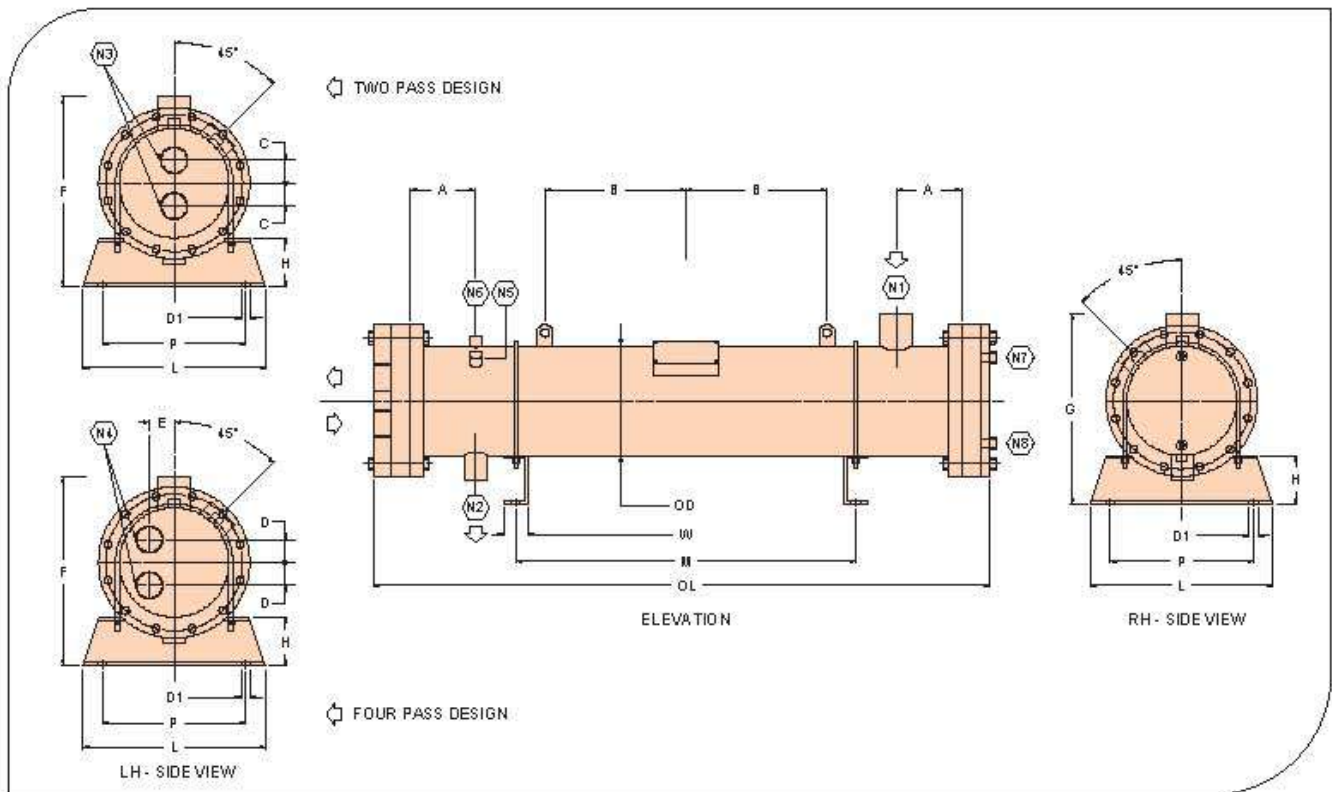

MODEL			BCD 160	BCD 180	BCD 210	BCD 235	BCD 260	BCD 285	BCD 335	BCD 390	BCD 440	BCD 520
DETAILS	SIGN	UNIT										
Dimension	OD	mm	168	219	219	219	219	273	273	273	273	273
	OL	mm	1500	1500	1500	1500	1500	1500	1500	1500	1500	1500
	A	mm	100	110	110	110	110	140	140	140	140	140
	B	mm	480	450	450	450	450	420	420	420	420	420
	C	mm	45	50	50	50	50	60	60	60	60	60
	D	mm	35	45	45	45	45	60	60	60	60	60
	E	mm	35	45	45	45	45	60	60	60	60	60
	F	mm	333	419	419	419	419	453	453	453	453	453
Mounting Bracket	D1	mm	14	14	14	14	14	14	14	14	14	14
	P	mm	220	280	280	280	280	340	340	340	340	340
	L	mm	280	330	330	330	330	390	390	390	390	390
	W	mm	38	50	50	50	50	50	50	50	50	50
	M	mm	700	700	700	700	700	700	700	700	700	700
	H	mm	75	100	100	100	100	100	100	100	100	100
Connection	N1	-	RC 35	RC 42	RC 42	RC 42	RC 42	BC 54	BC 54	BC 54	BC 54	BC 54
	N2	-	RC 22	RC 28	RC 28	RC 28	RC 28	RC 35	RC 35	RC 35	RC 35	RC 35
	N3	-	TC 50	TC 65	TC 65	TC 65	TC 65	TC 80	TC 80	TC 80	TC 80	TC 80
	N4	-	TC 40	TC 50	TC 50	TC 50	TC 50	TC 80	TC 80	TC 80	TC 80	TC 80
	N5	In-NPT	1/4	1/4	1/4	1/4	1/4	1/4	1/4	1/4	1/4	1/4
	N6	In-NPT	3/8	3/8	3/8	3/8	3/8	1/2	1/2	1/2	1/2	1/2
	N7	In-NPT	3/8	3/8	3/8	3/8	3/8	3/8	3/8	3/8	3/8	3/8
	N8	In-NPT	3/8	3/8	3/8	3/8	3/8	3/8	3/8	3/8	3/8	3/8
Volumes	V-Ref	dm <sup>3</sup>	18.1	36.2	35	33.8	32	55.6	53.2	50.8	49.6	48.4
	V-H2O	dm <sup>3</sup>	8.3	10.1	11.3	12.5	14.2	16.7	19.1	21.4	22.6	23.8
Weight	W	Kg	79	103	106	109	114	161	168	174	177	180

- N1 Refrigerant Inlet
- N2 Refrigerant Outlet
- N3 Water Inlet/Outlet (2 Pass)
- N4 Water Inlet/Outlet (4 Pass)

- N5 Service Socket
- N6 Safety Valve Connection
- N7 Vent Connection
- N8 Water Drain Port

- OD Outer Diameter
- OL Overall Length
- V-Ref Refrigerant Volume
- V-H2O Water Volume

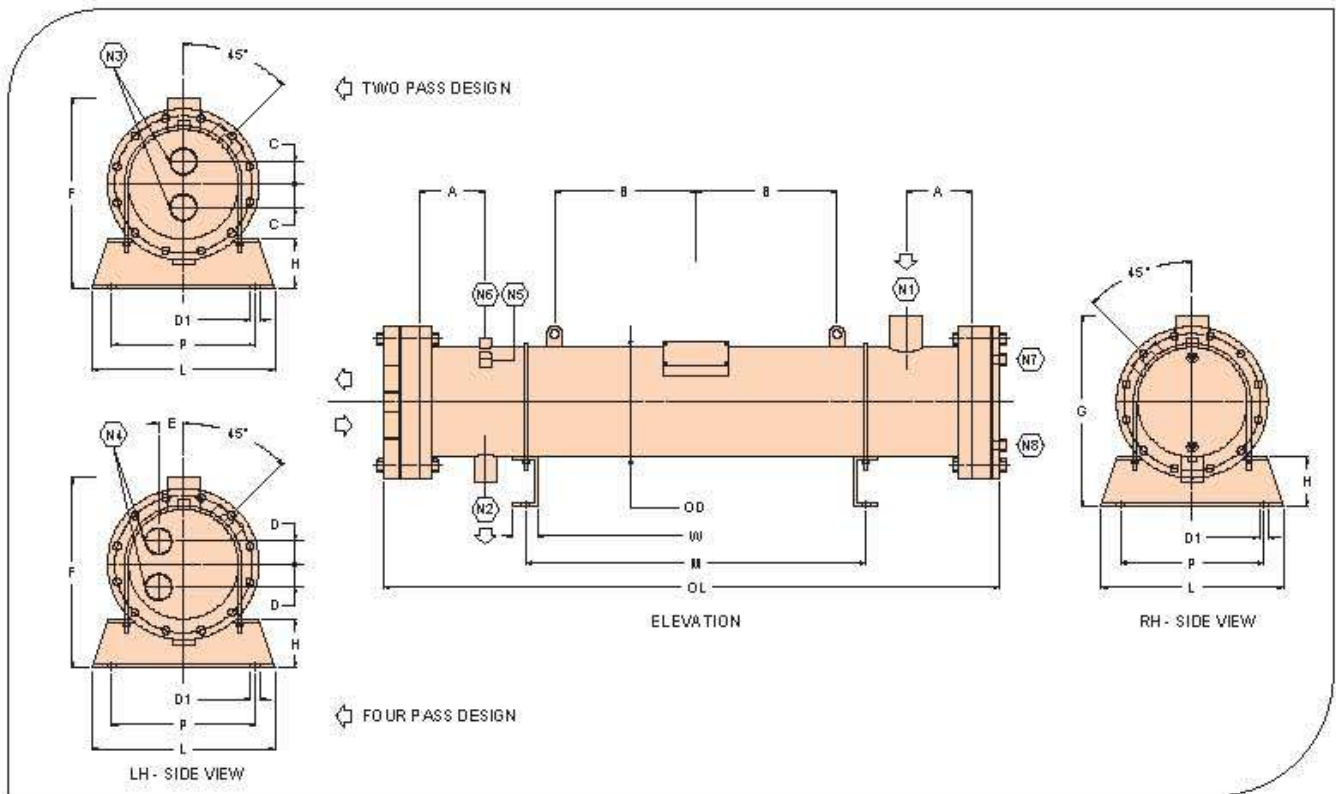

MODEL			BCD 180W	BCD 210W	BCD 235W	BCD 260W	BCD 390W	BCD 390X	BCD 520W	BCD 520X
DETAILS	SIGN	UNIT								
Dimension	OD	mm	219	219	219	219	273	273	273	273
	OL	mm	1900	1900	1900	1900	1900	2500	1900	2500
	A	mm	110	110	110	110	140	140	140	140
	B	mm	450	450	450	450	420	420	420	420
	C	mm	50	50	50	50	60	60	60	60
	D	mm	45	45	45	45	60	60	60	60
	E	mm	45	45	45	45	60	60	60	60
	F	mm	419	419	419	419	453	453	453	453
Mounting Bracket	D1	mm	14	14	14	14	14	14	14	14
	P	mm	280	280	280	280	340	340	340	340
	L	mm	330	330	330	330	390	390	390	390
	W	mm	50	50	50	50	50	50	50	50
	M	mm	1235	1235	1235	1235	1235	1235	1235	1235
	H	mm	100	100	100	100	100	100	100	100
Connection	N1	-	RC 42	RC 42	RC 42	RC 42	BC 54	BC 54	BC 54	BC 54
	N2	-	RC 28	RC 28	RC 28	RC 28	RC 35	RC 35	RC 35	RC 35
	N3	-	TC 65	TC 65	TC 65	TC 65	TC 80	TC 80	TC 80	TC 80
	N4	-	TC 50	TC 50	TC 50	TC 50	TC 80	TC 80	TC 80	TC 80
	N5	In-NPT	1/4	1/4	1/4	1/4	1/4	1/4	1/4	1/4
	N6	In-NPT	3/8	3/8	3/8	3/8	1/2	1/2	1/2	1/2
	N7	In-NPT	3/8	3/8	3/8	3/8	3/8	3/8	3/8	3/8
	N8	In-NPT	3/8	3/8	3/8	3/8	3/8	3/8	3/8	3/8
Volumes	V-Ref	dm <sup>3</sup>	47	45.5	44	41.7	66.1	89	63	85
	V-H2O	dm <sup>3</sup>	13	14.5	16.1	18.4	27.6	36.7	30.6	40.8
Weight	W	Kg	109	112	115	120	189	210	195	215

- N1 Refrigerant Inlet
- N2 Refrigerant Outlet
- N3 Water Inlet/Outlet (2 Pass)
- N4 Water Inlet/Outlet (4 Pass)

- N5 Service Socket
- N6 Safety Valve Connection
- N7 Vent Connection
- N8 Water Drain Port

- OD Outer Diameter
- OL Overall Length
- V-Ref Refrigerant Volume
- V-H2O Water Volume



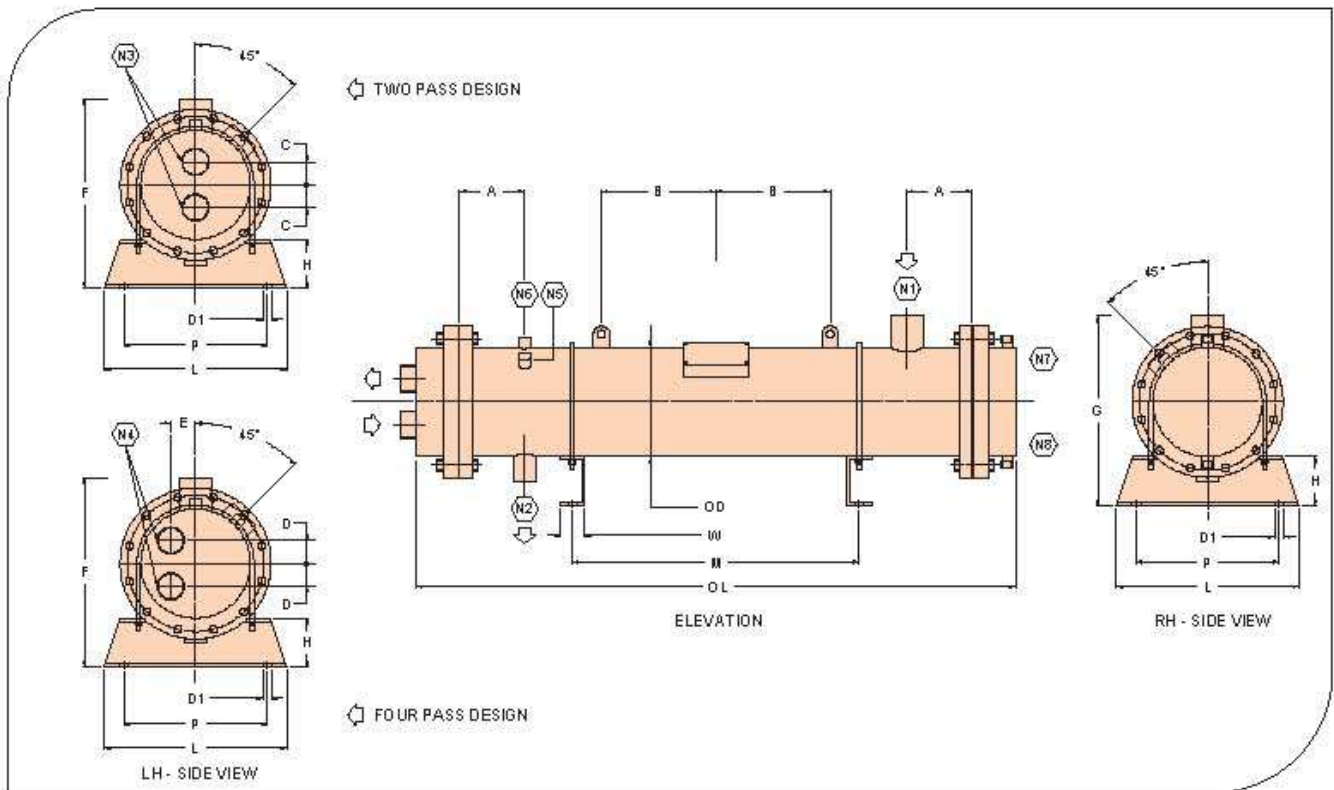

MODEL			BCD 470W	BCD 470X	BCD 530W	BCD 530X	BCD 550W	BCD 550X	BCD 610X	BCD 680X	BCD 760X
DETAILS	SIGN	UNIT									
Dimension	OD	mm	324	324	324	324	324	324	406	406	406
	OL	mm	1970	2570	1970	2570	1970	2570	2570	2570	2570
	A	mm	150	150	150	150	150	150	150	150	150
	B	mm	500	800	500	800	500	800	800	800	800
	C	mm	120	120	120	120	120	120	140	140	140
	D	mm	75	75	75	75	75	75	90	90	90
	E	mm	62	62	62	62	62	62	75	75	75
	F	mm	524	524	524	524	524	524	656	656	656
Mounting Bracket	D1	mm	14	14	14	14	14	14	18	18	18
	P	mm	380	380	380	380	380	380	480	480	480
	L	mm	440	440	440	440	440	440	585	585	585
	W	mm	50	50	50	50	50	50	75	75	75
	M	mm	1235	1835	1235	1835	1235	1835	1835	1835	1835
	H	mm	100	100	100	100	100	100	150	150	150
Connection	N1	-	PC 65	PC 65	PC 65	PC 65	PC 65	PC 65	PC 100	PC 100	PC 100
	N2	-	RC 42	RC 42	RC 42	RC 42	RC 42	RC 42	BC 54	BC 54	BC 54
	N3	-	FC 100	FC 100	FC 100	FC 100	FC 100	FC 100	FC 125	FC 125	FC 125
	N4	-	PC 100	PC 100	PC 100	PC 100	PC 100	PC 100	PC 125	PC 125	PC 125
	N5	In-NPT	1/4	1/4	1/4	1/4	1/4	1/4	1/4	1/4	1/4
	N6	In-NPT	1/2	1/2	1/2	1/2	1/2	1/2	1/2	1/2	1/2
	N7	In-NPT	3/8	3/8	3/8	3/8	3/8	3/8	1/2	1/2	1/2
	N8	In-NPT	3/8	3/8	3/8	3/8	3/8	3/8	1/2	1/2	1/2
Volumes	V-Ref	dm <sup>3</sup>	94.8	127.7	92.5	124.6	86.4	116.5	208.2	201.1	190.9
	V-H <sub>2</sub> O	dm <sup>3</sup>	39	52	41.3	55.1	47.5	63.3	71.4	78.6	88.8
Weight	W	Kg	307	335	315	345	330	365	525	540	565

- N1 Refrigerant Inlet
- N2 Refrigerant Outlet
- N3 Water Inlet/Outlet (2 Pass)
- N4 Water Inlet/Outlet (4 Pass)

- N5 Service Socket
- N6 Safety Valve Connection
- N7 Vent Connection
- N8 Water Drain Port

- OD Outer Diameter
- OL Overall Length
- V-Ref Refrigerant Volume
- V-H<sub>2</sub>O Water Volume

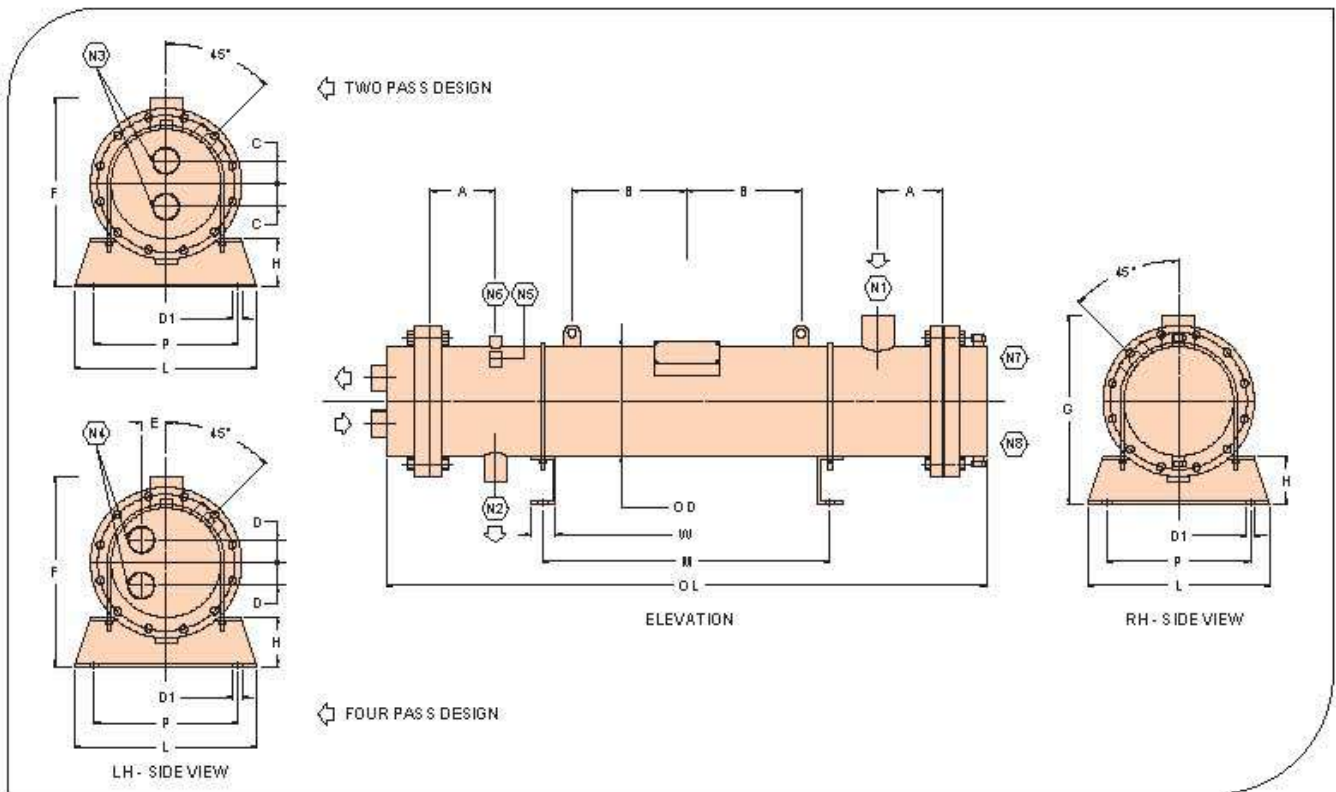

MODEL			BCD 840X	BCD 900X	BCD 900Y	BCD 940X	BCD 940Y	BCD 960Y	BCD 960Z	BCD 980Y	BCD 980Z
DETAILS	SIGN	UNIT									
Dimension	OD	mm	406	456	456	456	456	508	508	508	508
	OL	mm	2570	2570	2870	2570	2870	2870	3170	2870	3170
	A	mm	150	150	150	150	150	150	150	150	150
	B	mm	800	800	950	800	950	950	1100	950	1100
	C	mm	140	150	150	150	150	150	150	150	150
	D	mm	90	100	100	100	100	100	105	105	105
	E	mm	75	90	90	90	90	100	100	100	100
	F	mm	656	706	706	706	706	758	758	758	758
Mounting Bracket	D1	mm	18	18	18	18	18	18	18	18	18
	P	mm	480	530	530	530	530	580	580	580	580
	L	mm	585	635	635	635	635	635	635	635	635
	W	mm	75	75	75	75	75	75	75	75	75
	M	mm	1835	1835	2115	1835	2115	2115	2630	2115	2630
	H	mm	150	150	150	150	150	150	150	150	150
Connection	N1	-	PC 100	PC 100	PC 100	PC 100	PC 100	PC 100	PC 100	PC 100	PC 100
	N2	-	BC 54	BC 54	BC 54	BC 54	BC 54	BC 54	BC 54	BC 54	BC 54
	N3	-	FC 125	FC 150	FC 150	FC 150	FC 150	FC 150	FC 150	FC 150	FC 150
	N4	-	PC 125	PC 125	PC 125	PC 125	PC 125	PC 125	PC 125	PC 125	PC 125
	N5	In-NPT	1/4	1/4	1/4	1/4	1/4	1/4	1/4	1/4	1/4
	N6	In-NPT	1/2	1/2	1/2	1/2	1/2	1/2	1/2	1/2	1/2
	N7	In-NPT	1/2	1/2	1/2	1/2	1/2	1/2	1/2	1/2	1/2
	N8	In-NPT	1/2	1/2	1/2	1/2	1/2	1/2	1/2	1/2	1/2
Volumes	V-Ref	dm <sup>3</sup>	186.8	257.1	290.4	234.6	265.1	333.2	371.5	312.6	348.5
	V-H <sub>2</sub> O	dm <sup>3</sup>	92.9	102.1	114.8	124.5	140	160.7	178.6	181.4	201.6
Weight	W	Kg	575	665	715	710	760	925	990	980	1050

- N1 Refrigerant Inlet
- N2 Refrigerant Outlet
- N3 Water Inlet/Outlet (2 Pass)
- N4 Water Inlet/Outlet (4 Pass)

- N5 Service Socket
- N6 Safety Valve Connection
- N7 Vent Connection
- N8 Water Drain Part

- OD Outer Diameter
- OL Overall Length
- V-Ref Refrigerant Volume
- V-H<sub>2</sub>O Water Volume



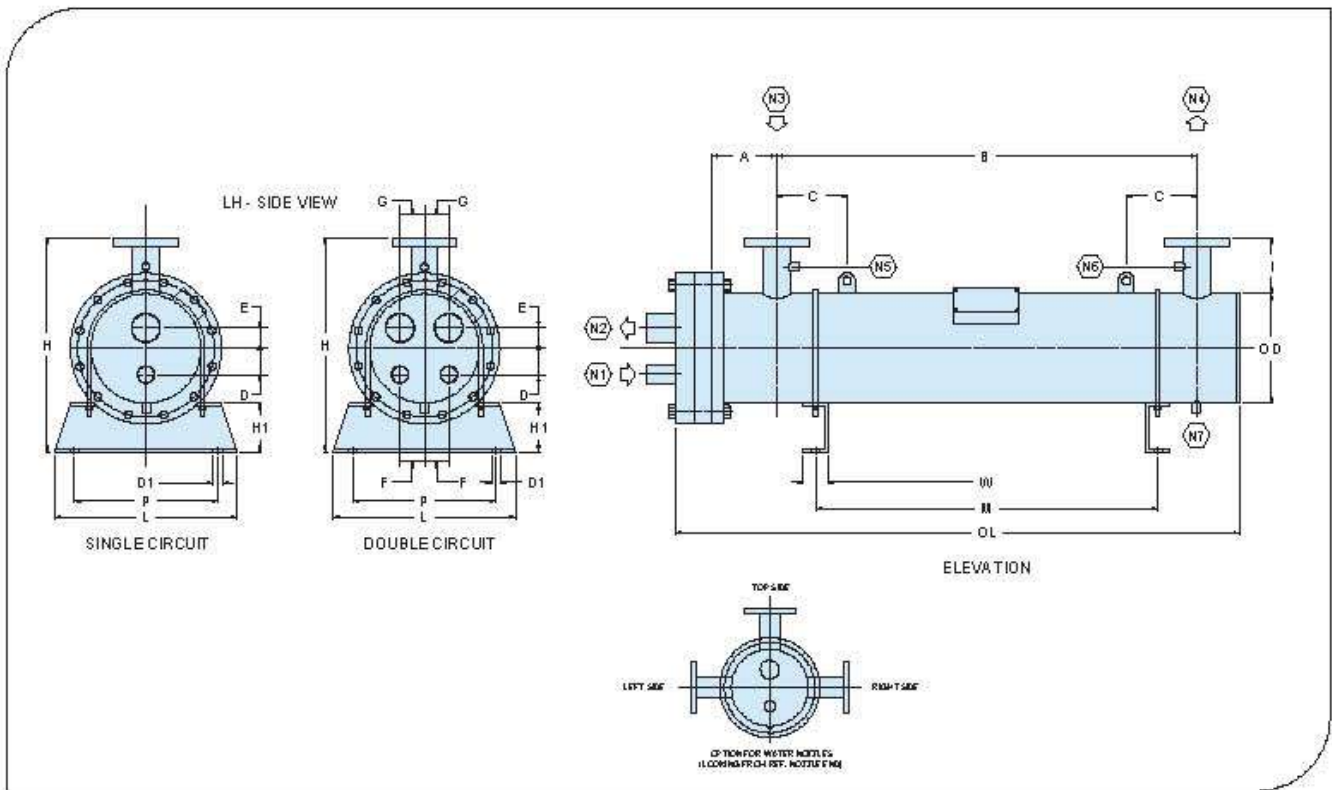

MODEL			BCH 18S	BCH 28S	BCH 35S	BCH 47S	BCH 56S	BCH 65S	BCH 80S	BCH 95S	
DETAILS	SIGN	UNIT	BCH 18D	BCH 28D	BCH 35D	BCH 47D	BCH 56D	BCH 65D	BCH 80D	BCH 95D	
Dimension	OD	mm	140	140	140	140	168	168	168	168	
	OL	mm	887	1037	1257	1407	1281	1431	1631	1781	
	A	mm	85	85	85	85	95	95	95	95	
	B	mm	690	840	1040	1190	1030	1180	1380	1530	
	C	mm	175	175	180	180	190	190	190	190	
	D	mm	35   30	35   30	35   30	35   30	40   35	40   35	40   35	40   35	40   35
	E	mm	35   28	35   28	35   28	35   28	40   35	40   35	40   35	40   35	40   35
	F	mm	32	32	32	32	37	37	37	37	37
	G	mm	33	33	33	33	37	37	37	37	37
	H	mm	345	345	345	345	373	373	373	373	373
	I	mm	130	130	130	130	130	130	130	130	130
	J	mm	-	-	-	-	-	-	-	-	-
K	mm	-	-	-	-	-	-	-	-	-	
Mounting Bracket	D1	mm	14	14	14	14	14	14	14	14	
	P	mm	200	200	200	200	220	220	220	220	
	L	mm	250	250	250	250	280	280	280	280	
	W	mm	38	38	38	38	38	38	38	38	
	M	mm	490	640	830	980	800	950	1150	1300	
	H1	mm	75	75	75	75	75	75	75	75	75
Connection	N1	-	RC 22   16	RC 22   16	RC 22   16	RC 22   16	RC 22   22	RC 22   22	RC 22   22	RC 22   22	
	N2	-	RC 35   28	RC 35   28	RC 35   28	RC 35   28	RC 42   35	RC 42   35	RC 42   35	RC 42   35	
	N3	-	FC 40	FC 40	FC 50	FC 50	FC 65	FC 65	FC 65	FC 65	
	N4	-	FC 40	FC 40	FC 50	FC 50	FC 65	FC 65	FC 65	FC 65	
	N5 / N6	Inch	0.5	0.5	0.5	0.5	0.5	0.5	0.5	0.5	
	N7	Inch	0.5	0.5	0.5	0.5	0.5	0.5	0.5	0.5	
	Volumes	V-Ref	dm <sup>3</sup>	3.3	4.1	5	5.7	7.4	8.4	9.6	30.6
V-H2O	dm <sup>3</sup>	7.2	8.7	10.7	12.2	16.1	18.3	21	23		
Weight	W	Kg	41	44	52	56	65	70	76	81	

N1 Refrigerant Inlet  
 N2 Refrigerant Outlet  
 N3 Water Inlet  
 N4 Water Outlet

N5 Service Socket  
 N6 Service Socket  
 N7 Water Drain Part

OD Outer Diameter  
 OL Overall Length  
 V-Ref Refrigerant Volume  
 V-H2O Water Volume

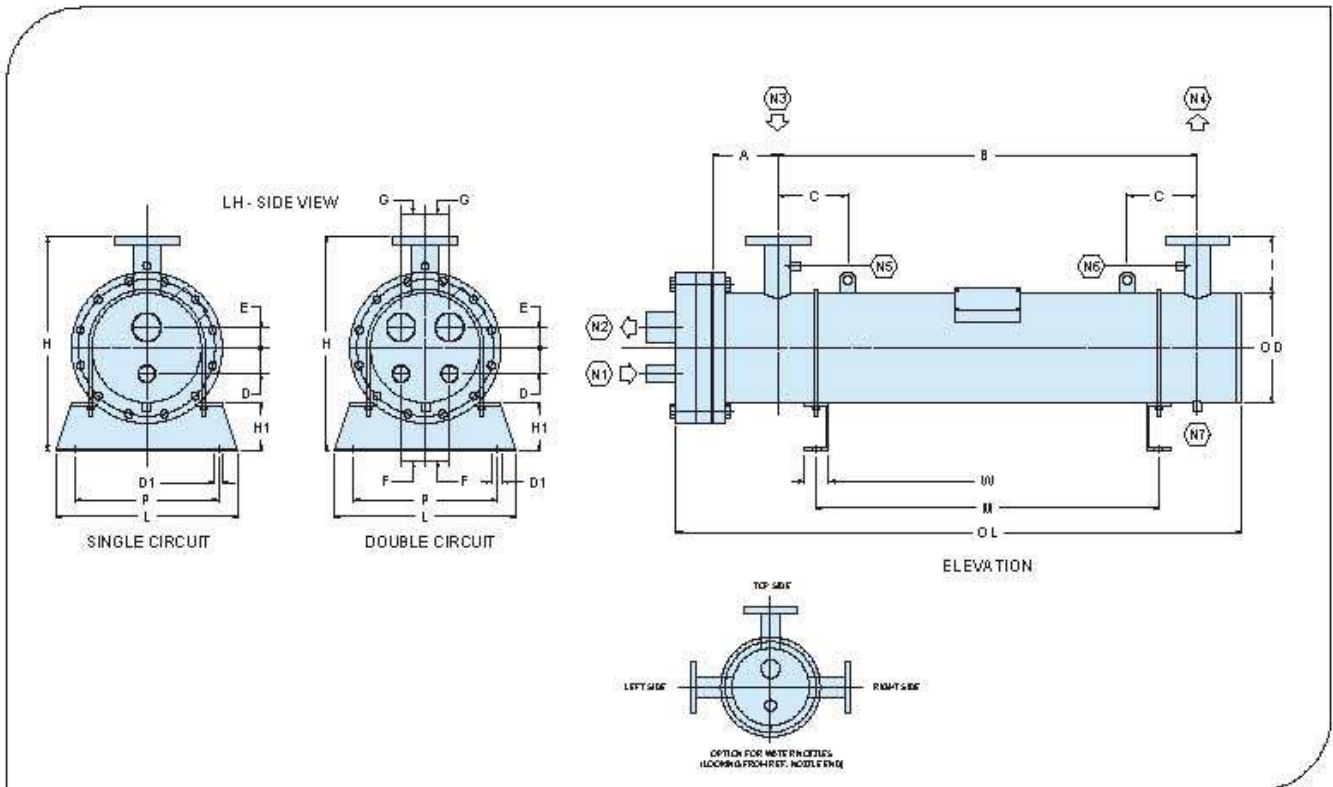

MODEL			BCH 100S	BCH 120S	BCH 135S	BCH 165S	BCH 200S	BCH 240S	BCH 245S
DETAILS	SIGN	UNIT	BCH 100D	BCH 120D	BCH 135D	BCH 165D	BCH 200D	BCH 240D	BCH 245D
Dimension	OD	mm	219	219	219	219	219	219	273
	OL	mm	1215	1465	1685	1845	2320	2620	1635
	A	mm	105	105	105	105	125	125	130
	B	mm	960	1210	1430	1590	2000	2300	1340
	C	mm	190	190	195	195	210	210	210
	D	mm	45   50	45   50	45   50	45   50	45   50	45   50	65   55
	E	mm	55   44	55   44	55   44	55   44	55   44	55   44	65   60
	F	mm	47	47	47	47	47	47	57
	G	mm	47	47	47	47	47	47	57
	H	mm	469	469	469	469	469	469	523
	I	mm	130	130	130	130	150	150	150
	J	mm	-	-	-	-	-	-	-
K	mm	-	-	-	-	-	-	-	
Mounting Bracket	D1	mm	14	14	14	14	14	14	14
	P	mm	280	280	280	280	280	280	340
	L	mm	330	330	330	330	330	330	390
	W	mm	50	50	50	50	50	50	50
	M	mm	730	980	1190	1350	1760	2060	1070
	H1	mm	100	100	100	100	100	100	100
Connection	N1	-	RC 28   28	RC 28   28	RC 28   28	RC 28   28	RC 35   28	RC 35   28	RC 35   35
	N2	-	BC 54   RC 42	BC 54   RC 42	BC 54   RC 42	BC 54   RC 42	BC 67   RC 42	BC 67   RC 42	BC 67   54
	N3	-	FC 65	FC 65	FC 80	FC 80	FC 100	FC 100	FC 100
	N4	-	FC 65	FC 65	FC 80	FC 80	FC 100	FC 100	FC 100
	N5 / N6	Inch	0.5	0.5	0.5	0.5	0.5	0.5	0.5
	N7	Inch	0.5	0.5	0.5	0.5	0.5	0.5	0.5
	Volumes	V-Ref.	dm <sup>3</sup>	12.6	15.4	17.9	19.7	24.8	28.3
	V-H2O	dm <sup>3</sup>	26.6	32.4	37.5	41.2	51.7	58.7	55.4
Weight	W	Kg	93	106	117	125	151	172	183

N1 Refrigerant Inlet  
 N2 Refrigerant Outlet  
 N3 Water Inlet  
 N4 Water Outlet

N5 Service Socket  
 N6 Service Socket  
 N7 Water Drain Port

OD Outer Diameter  
 OL Overall Length  
 V-Ref Refrigerant Volume  
 V-H2O Water Volume



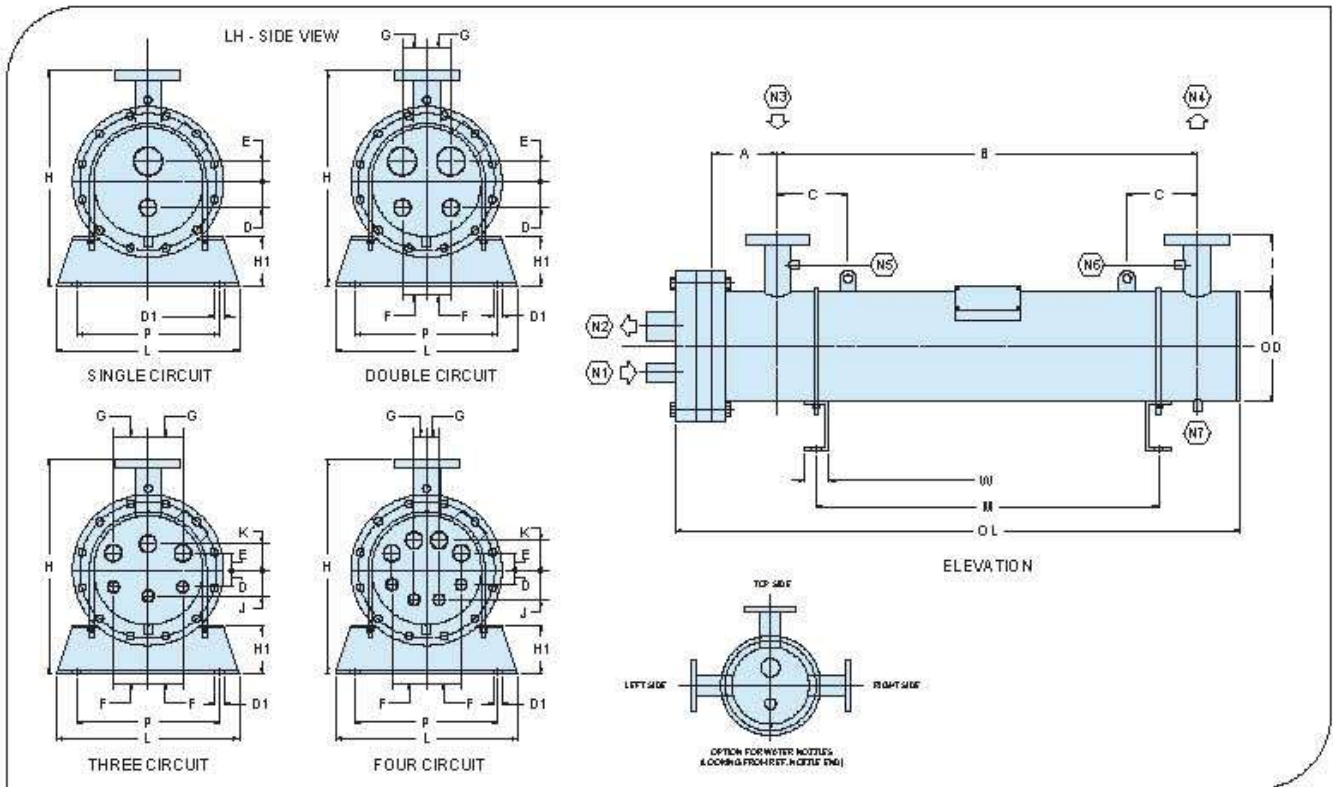

MODEL			BCH 245T	BCH 300S	BCH 300T	BCH 345S	BCH 345T	BCH 385S	BCH 385T
DETAILS	SIGN	UNIT	BCH 245Q	BCH 300D	BCH 300Q	BCH 345D	BCH 345Q	BCH 385D	BCH 385Q
Dimension	OD	mm	273	273	273	273	273	273	273
	OL	mm	1635	1985	1985	2385	2385	2654	2654
	A	mm	130	130	130	130	130	130	130
	B	mm	1340	1690	1690	2090	2090	2280	2280
	C	mm	210	210	210	210	210	210	210
	D	mm	52   38	65   55	52   38	65   55	52   38	65   55	52   38
	E	mm	52   38	65   60	52   38	65   60	52   38	65   60	52   38
	F	mm	80   38	57	80   38	57	80   38	57	80   38
	G	mm	80   90	57	80   90	57	80   90	57	80   90
	H	mm	523	523	523	523	523	523	523
	I	mm	150	150	150	150	150	150	150
	J	mm	80   90	-	80   90	-	80   90	-	80   90
K	mm	80   90	-	80   90	-	80   90	-	80   90	
Mounting	D1	mm	14	14	14	14	14	14	14
	P	mm	340	340	340	340	340	340	340
	L	mm	390	390	390	390	390	390	390
	W	mm	50	50	50	50	50	50	50
	M	mm	1070	1420	1420	1820	1820	2010	2010
	H1	mm	100	100	100	100	100	100	100
Connection	N1	-	RC 35   22	RC 42   35	RC 35   22	RC 42   35	RC 35   22	RC 42   35	RC 35   22
	N2	-	BC 54   RC 42	PC 80   BC 54	BC 54   RC 42	PC 80   BC 54	BC 54   RC 42	PC 80   BC 54	BC 54   RC 42
	N3	-	FC 100	FC 100	FC 100	FC 100	FC 100	FC 100	FC 100
	N4	-	FC 100	FC 100	FC 100	FC 100	FC 100	FC 100	FC 100
	N5 / N6	Inch	0.5	0.5	0.5	0.5	0.5	0.5	0.5
	N7	Inch	0.5	0.5	0.5	0.5	0.5	0.5	0.5
	Volumes	V-Ref.	dm <sup>3</sup>	28.3   26.3	34.8	34.8   32.2	42.2	42.2   39	46.6
V-H2O		dm <sup>3</sup>	55.3   57.4	67.7	67.6   70.2	81.7	81.6   84.8	89.9	89.9   93.4
Weight	W	Kg	183	213	213	248	248	262	262

N1 Refrigerant Inlet  
 N2 Refrigerant Outlet  
 N3 Water Inlet  
 N4 Water Outlet

N5 Service Socket  
 N6 Service Socket  
 N7 Water Drain Part

OD Outer Diameter  
 OL Overall Length  
 V-Ref Refrigerant Volume  
 V-H2O Water Volume

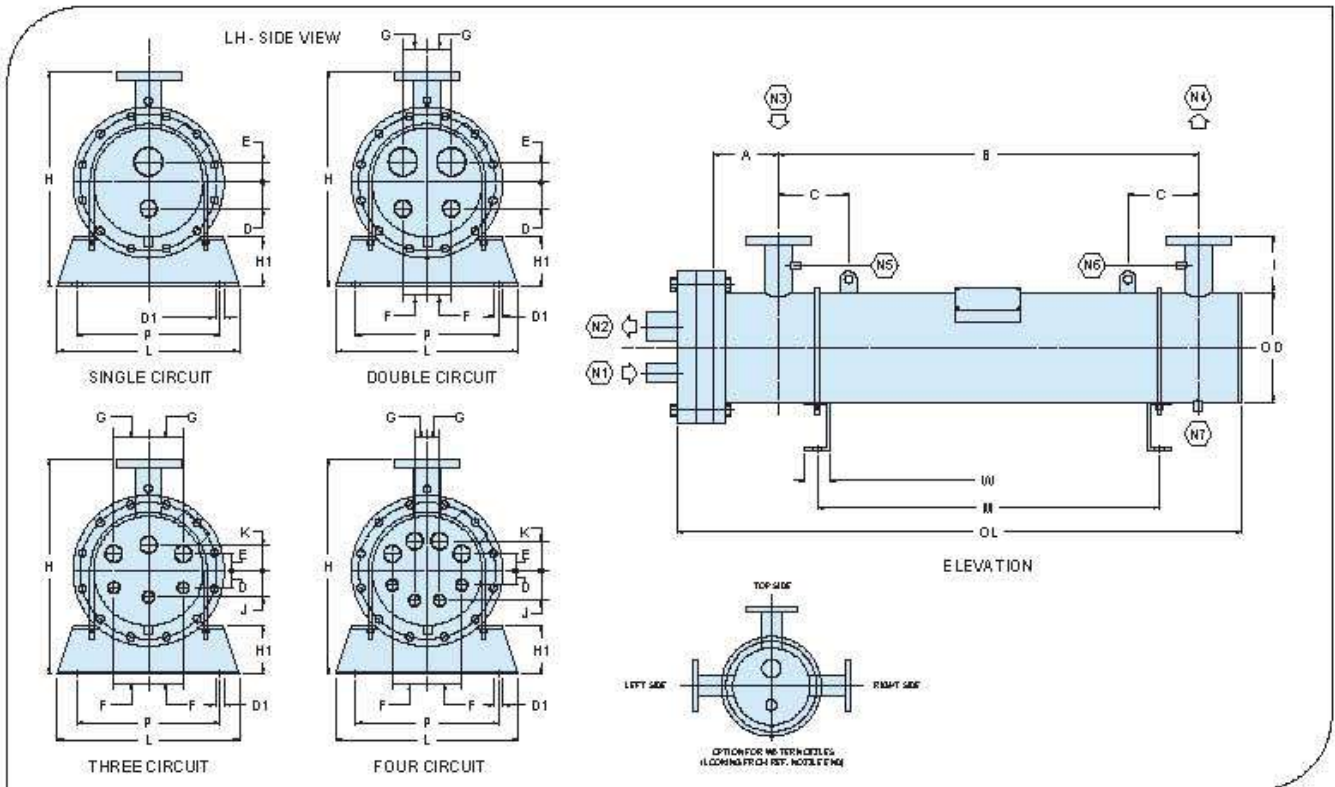

MODEL			BCH 400D	BCH 400Q	BCH 435D	BCH 435Q	BCH 450D	BCH 450Q	BCH 505D
DETAILS	SIGN	UNIT	BCH 400T		BCH 435T		BCH 450T		BCH 505T
Dimension	OD	mm	324	324	324	324	324	324	324
	OL	mm	1790	1790	2020	2020	2120	2120	2425
	A	mm	175	175	175	175	175	175	175
	B	mm	1385	1385	1615	1615	1715	1715	2020
	C	mm	235	235	235	235	235	235	235
	D	mm	75   60	45	75   60	45	75   60	45	75   60
	E	mm	65   60	45	65   60	45	65   60	45	65   60
	F	mm	70   90	39	70   90	39	70   90	39	70   90
	G	mm	70   90	105	70   90	105	70   90	105	70   90
	H	mm	574	574	574	574	574	574	574
	I	mm	150	150	150	150	150	150	150
	J	mm	75	102	75	102	75	102	75
K	mm	75	102	75	102	75	102	75	
Mounting	D1	mm	14	14	14	14	14	14	14
	P	mm	380	380	380	380	380	380	380
	L	mm	440	440	440	440	440	440	440
	W	mm	50	50	50	50	50	50	50
	M	mm	1065	1065	1295	1295	1395	1395	1700
	H1	mm	100	100	100	100	100	100	100
Connection	N1	-	RC 42   35	RC 35	RC 42   35	RC 35	RC 42   35	RC 35	RC 42   35
	N2	-	PC 80   BC 54	BC 54	PC 80   BC 54	BC 54	PC 80   BC 54	BC 54	PC 80   BC 54
	N3	-	FC 150	FC 150	FC 150	FC 150	FC 150	FC 150	FC 150
	N4	-	FC 150	FC 150	FC 150	FC 150	FC 150	FC 150	FC 150
	N5 / N6	Inch	0.5	0.5	0.5	0.5	0.5	0.5	0.5
	N7	Inch	1	1	1	1	1	1	1
	Volumes	V-Ref.	dm <sup>3</sup>	47.6	44.2	54.1	50.2	57	52.8
V-H <sub>2</sub> O		dm <sup>3</sup>	82.9	86.3	94	97.8	98.7	102.8	113.1
Weight	W	kg	290	270	303	282	320	298	342

- N1 Refrigerant Inlet
- N2 Refrigerant Outlet
- N3 Water Inlet
- N4 Water Outlet

- N5 Service Socket
- N6 Service Socket
- N7 Water Drain Part

- OD Outer Diameter
- OL Overall Length
- V-Ref Refrigerant Volume
- V-H<sub>2</sub>O Water Volume



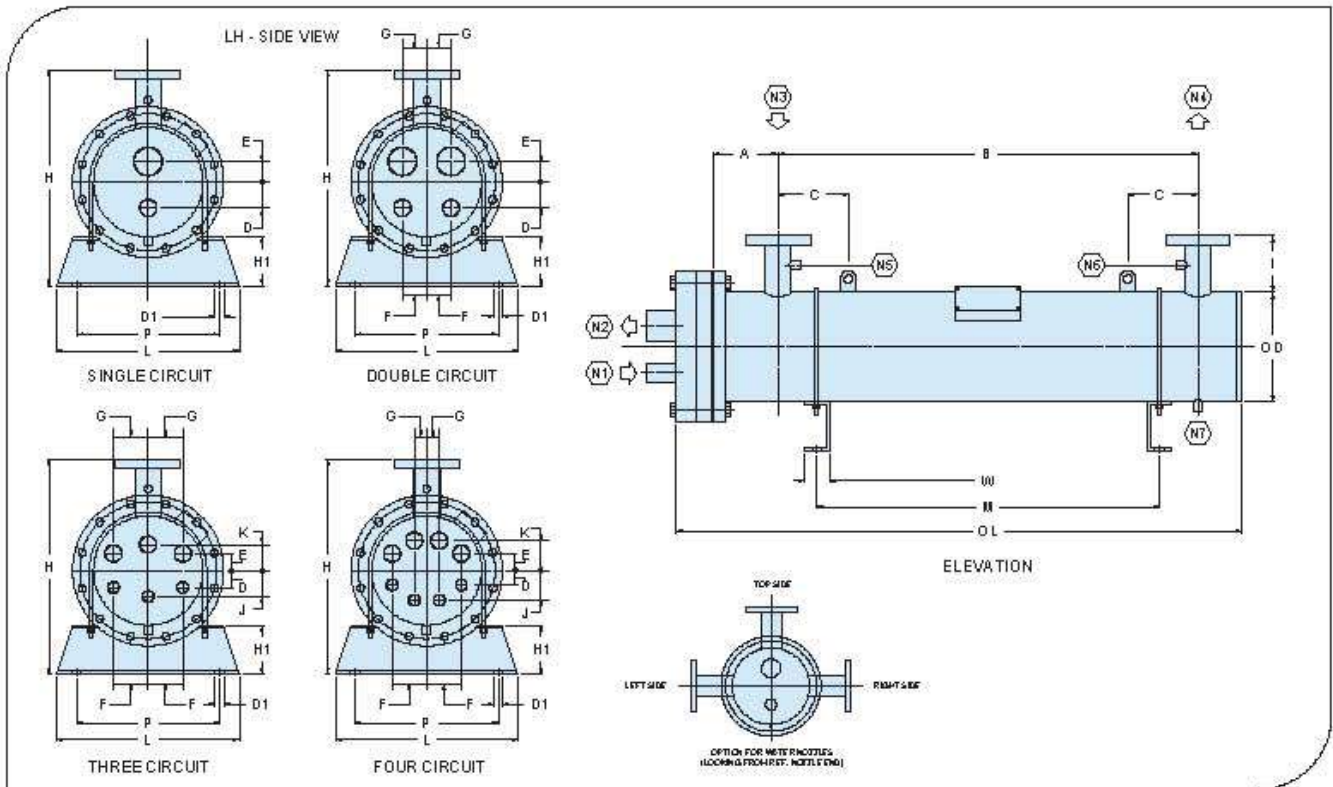

MODEL			BCH 505Q	BCH 570D BCH 570T	BCH 570Q	BCH 630D	BCH 660D	BCH 770D	BCH 915D
DETAILS	SIGN	UNIT							
Dimension	OD	mm	324	324	324	356	406	406	406
	OL	mm	2425	2525	2525	2750	2230	2430	2580
	A	mm	175	175	175	175	180	180	180
	B	mm	2020	2120	2120	2350	1805	2005	2155
	C	mm	235	235	235	235	235	235	235
	D	mm	45	75   60	45	75	90	90	90
	E	mm	45	65   60	45	75	90	90	90
	F	mm	39	70   90	39	75	85	85	85
	G	mm	105	70   90	105	75	85	85	85
	H	mm	574	574	574	606	706	706	706
	I	mm	150	150	150	150	150	150	150
	J	mm	102	75	102	-	-	-	-
K	mm	102	75	102	-	-	-	-	
Mounting	D1	mm	14	14	14	14	18	18	18
	P	mm	380	380	380	420	480	480	480
	L	mm	440	440	440	470	585	585	585
	W	mm	50	50	50	50	75	75	75
	M	mm	1700	1800	1800	2030	1485	1685	1835
	H1	mm	100	100	100	100	150	150	150
Connection	N1	-	RC 35	RC 42   35	RC 35	BC 54	BC 54	BC 54	BC 54
	N2	-	BC 54	PC 80   BC 54	BC 54	PC 100	PC 100	PC 100	PC 100
	N3	-	FC 150	FC 150	FC 150	FC 150	FC 150	FC 150	FC 150
	N4	-	FC 150	FC 150	FC 150	FC 150	FC 150	FC 150	FC 150
	N5 / N6	Inch	0.5	0.5	0.5	0.5	0.5	0.5	0.5
	N7	Inch	1	1	1	1	1	1	1
Volumes	V-Ref.	dm <sup>3</sup>	60.7	68.4	63.4	88.1	100	109.6	116.8
	V-H <sub>2</sub> O	dm <sup>3</sup>	117.8	117.9	122.9	145.7	155.4	162.9	173.6
Weight	W	Kg	327	365	335	410	490	512	525

N1 Refrigerant Inlet  
 N2 Refrigerant Outlet  
 N3 Water Inlet  
 N4 Water Outlet

N5 Service Socket  
 N6 Service Socket  
 N7 Water Drain Part

OD Outer Diameter  
 OL Overall Length  
 V-Ref Refrigerant Volume  
 V-H<sub>2</sub>O Water Volume

Shell In Shell Evaporator

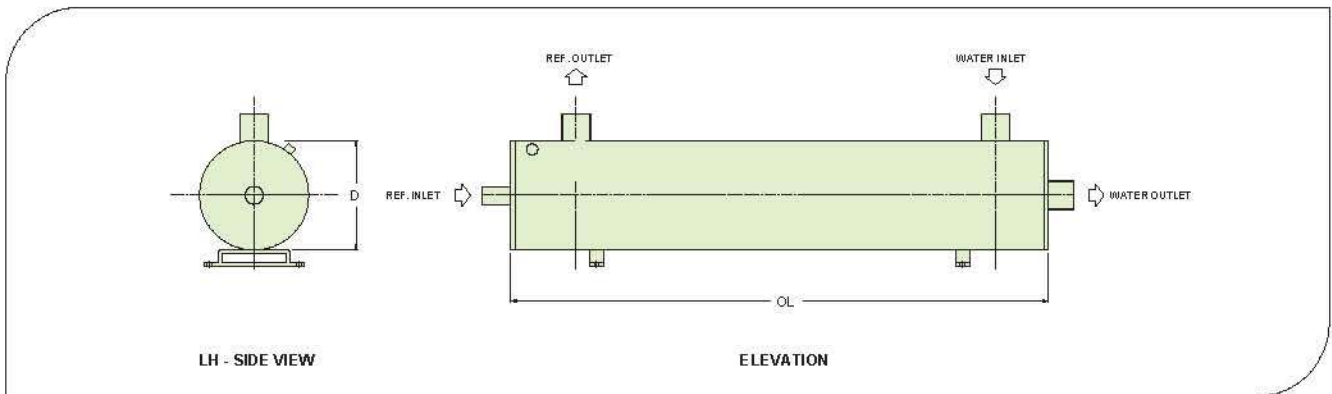

Sr.	Model no	Capacity (TR)	Dia. (Inch)	Length (mm)
1	BS-04-015	1.5	5	460
2	BS-04-020	2	5	535
3	BS-04-030	3	5	685
4	BS-04-050	5	5.5	815
5	BS-04-075	7.5	6	1220
6	BS-04-100	10	6	1425
7	BS-04-125	12.5	6.5	1525
8	BS-04-150	15	6.5	1905

Sr.	Model no	Capacity (TR)	Dia. (Inch)	Length (mm)
1	BS-16-015	1.5	5	460
2	BS-16-020	2	5	610
3	BS-16-030	3	5	760
4	BS-16-050	5	5.5	890
5	BS-16-075	7.5	6	1220
6	BS-16-100	10	6.5	1425
7	BS-16-125	12.5	6.5	1600
8	BS-16-150	15	6.5	1980

Oil Cooler



Oil cooler is an Industrial utility to run the plant/system to deliver uninterrupted production. Shell & Tube design delivers better results & support to run the system safely.

Optimized design against specific requirements with Copper/SS/MS tube material with new variety of geometry having enhanced surface area for efficient heat transfer.

- Enquiries shall be reciprocated with best design / offer.

Inter Cooler / After Cooler



After Cooler is an equipment clubbed with Air Compressor to deliver required conditioned air to operate pneumatic machineries uninterrupted.

**FITZER** designs the equipment with Copper tubes for better heat transfer having latest tube geometry having enhanced surface area for improving performance.

- Enquiries shall be reciprocated with best design / offer.



**Bush Connection (BC)**

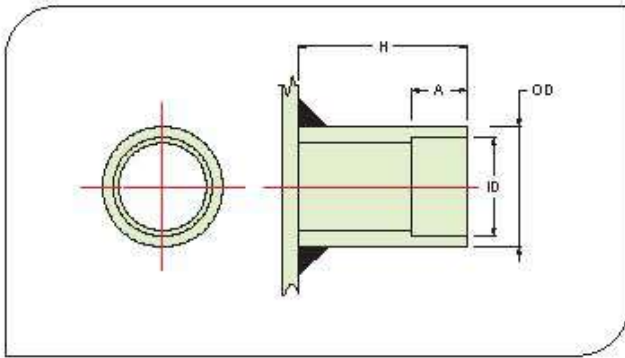

Type	OD [mm]	ID [mm]	A [mm]	H [mm]
BC16	21.8	16.2	15	60
BC22	27.3	22.5	15	60
BC28	34.2	28.9	20	60
BC35	42.9	35.3	20	60
BC42	48.8	41.7	30	80
BC54	60.8	54	30	80
BC67	76.6	67	40	100

**Rotolock Connection (RC)**

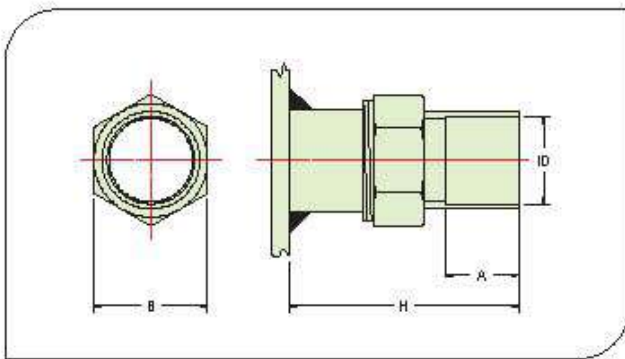

Type	Thread	ODS [Inch]	ID [mm]	A [mm]	B [mm]	H [mm]
RC13	1" - UNS	1/2	13	16	30	55
RC16	1" - UNS	5/8	16.2	16	30	55
RC19	1-1/4" - UNF	3/4	19.3	22	36	70
RC22	1-1/4" - UNF	7/8	22.5	22	36	70
RC28	1-3/4" - UN	1-1/8	28.9	22	50	85
RC35	1-3/4" - UN	1-3/8	35.3	35	50	90
RC42	2-1/4" - UN	1-5/8	41.7	35	62	100

**Pipe Connection (PC)**

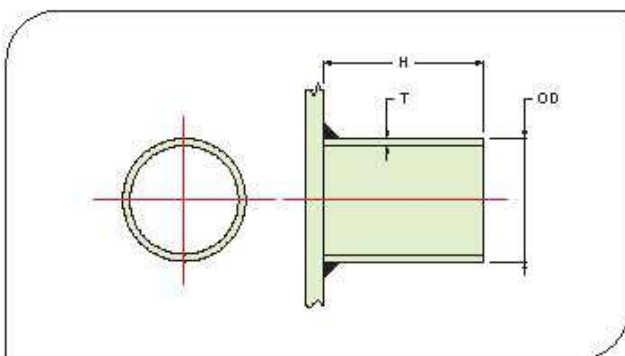

Type	OD [Inch]	T [mm]	H [mm]
PC 50	60.8	4.5	100
PC 65	76.6	4.5	100
PC 80	89.9	4.85	100
PC 100	115	5.4	100
PC 125	140.8	5.4	100
PC 150	166.5	5.4	100

**Threaded Connection (TC) / NPT Coupling Connection (NC)**

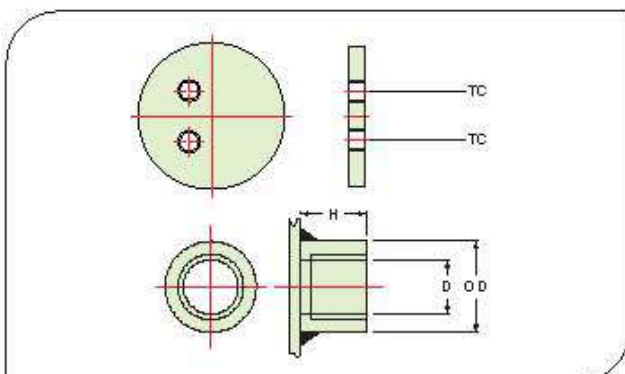

Type	Thread	D [Inch]
TC 25	BSP	1
TC 40	BSP	1.5
TC 50	BSP	2
TC 65	BSP	2.5
TC 80	BSP	3

Type	D [Inch]	OD [mm]	H [mm]
NC 14	1/4	20	21
NC 38	3/8	25	21
NC 12	1/2	30	25
NC 01	1	40	30

**Flange Connection (FC)**

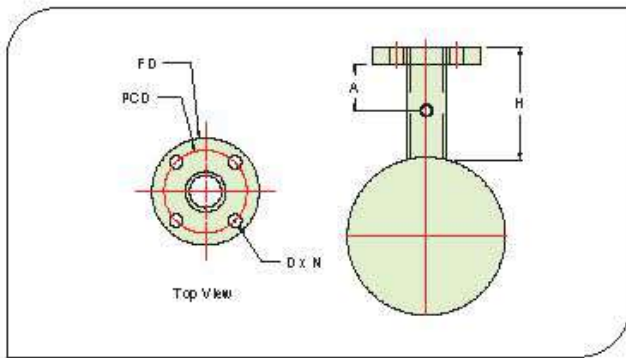

Type	DN [ inch ]	H [ mm ]	A [ mm ]	FD [ mm ]	PCD [ mm ]	D [ mm ]	N [ Nos. ]
FC40	1.5	130	55	127	98	16	4
FC50	2	130	55	152	120	19	4
FC65	2.5	130	55	178	140	19	4
FC80	3	150	65	190	152	19	4
FC100	4	150	65	228	190	19	8
FC150	6	150	65	279	241	22	8

**BSP Coupling Connection (CC)**

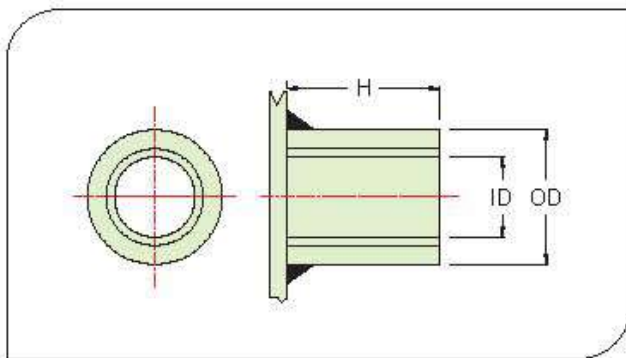

Type	D [ mm ]	H [ mm ]
CC40	55	55
CC50	70	65
CC65	85	70
CC80	100	75
CC100	125	90

**Victaulic Pipe Connection (VPC)**

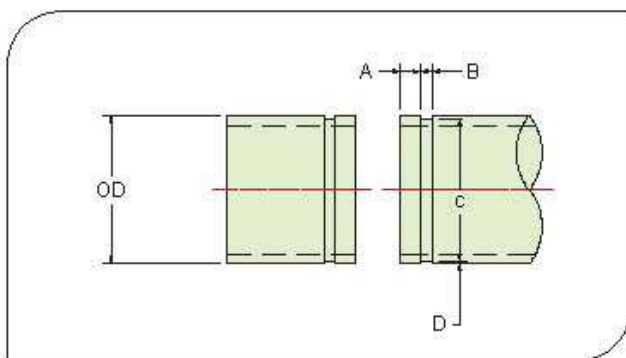

Type	DN [ inch ]	OD [ mm ]	A [ mm ]	B [ mm ]	C [ mm ]	D [ mm ]
VPC40	1.5	48.3	15.88	7.14	45.09	1.6
VPC50	2	60.3	15.88	8.74	57.15	1.6
VPC65	2.5	73	15.88	8.74	69.09	1.98
VPC80	3	88.9	15.88	8.74	84.94	1.98
VPC100	4	114.3	15.88	8.74	110.08	2.11
VPC125	5	141.3	15.88	8.74	137.03	2.13
VPC150	6	168.3	15.88	8.74	163.96	2.16

**Victaulic Coupling Connection (VC)\***

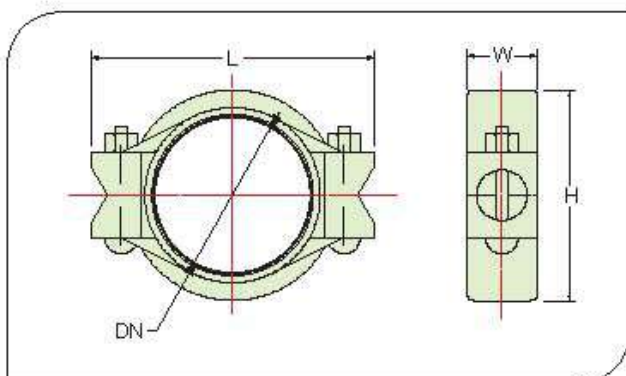

Type	DN [ inch ]	L [ mm ]	H [ mm ]	W [ mm ]
VC40	1.5	112	70	44
VC50	2	124	82	44
VC65	2.5	148	96	44
VC80	3	166	113	44
VC100	4	193	140	48
VC125	5	222	167	50
VC150	6	252	196	44

\* Will be provided on special request at additional cost.



# Pressure - Temperature Chart



TEMP °C	R12		R134A		SP34E		R409A		R22		R410A		R419A		R407C		R502		R404A		R408A		R507	
	kPa	psig	kPa	psig	kPa	psig	kPa	psig	kPa	psig	kPa	psig	kPa	psig	kPa	psig	kPa	psig	kPa	psig	kPa	psig	kPa	psig
-42	43	12.7	55	16.3			55	16.0	5	1.6	56.2	8.2	26	3.8	24.6	7.2	17	25	18	2.6	9	1.3	27	3.9
-38	30.9	9.1	45	13.2	44.6	13.1	44	12.9	14	2.0	87.9	12.7	9	1.3	7.5	2.2	40	58	42	6.1	30	4.4	52	7.5
-34	17	5.0	32	9.4	31.9	9.4	32	9.1	36	5.2	130	18.9	10	1.5	12.4	1.8	67	97	69	10.0	55	8.0	81	11.7
-30	-1	0.3	17	5.0	17	5	17	4.8	62	9.0	172	24.9	32	4.6	35	5.1	97	14.1	99	14.4	84	12.2	113	16.4
-28	8	1.1	9	2.6	8.6	2.5	9	2.3	76	11.0	194	28.1	45	6.5	48	7.0	113	16.4	116	16.8	100	14.5	131	19.0
-26	17	2.5	0	0.0	0.5	0.1	0.7	0.1	92	13.3	219	31.8	58	8.4	62	9.0	131	19.0	134	19.4	117	17.0	150	21.8
-24	27	3.9	10	1.5	10.1	1.5	9	1.3	108	15.7	244	35.4	73	10.6	77	11.2	149	21.6	154	22.3	135	19.5	170	24.7
-22	38	5.5	20	2.9	20.5	3	19	2.6	125	18.1	272	39.5	88	12.8	93	13.5	169	24.5	174	25.2	154	22.3	192	27.8
-20	50	7.3	31	4.5	31.7	4.6	29	4.2	143	20.7	301	43.7	104	15.1	110	16.0	190	27.6	196	28.4	174	25.2	214	31.0
-18	62	9.0	43	6.2	43.5	6.3	41	5.9	163	23.6	332	48.2	122	17.7	128	18.6	212	30.7	219	31.8	195	28.3	238	34.5
-16	75	10.9	56	8.1	56.3	8.2	53	7.7	184	26.7	364	52.8	140	20.3	148	21.5	235	34.1	243	35.2	218	31.5	264	38.3
-14	88	12.8	69	10.0	69.9	10.1	66	9.6	205	29.7	398	57.7	160	23.2	169	24.5	260	37.7	269	39.0	242	35.1	291	42.2
-12	103	14.9	84	12.2	84.3	12.2	80	11.6	229	33.2	435	63.1	181	26.3	191	27.7	286	41.5	296	42.9	267	38.7	319	46.3
-10	118	17.1	99	14.4	99.7	14.5	95	13.8	253	36.7	473	68.6	203	29.4	214	31.0	313	45.4	324	47.0	294	42.5	349	50.6
-8	134	19.4	115	16.7	116.1	16.8	111	16.1	279	40.6	513	74.4	227	32.9	239	34.7	342	49.6	355	51.6	322	46.7	380	55.1
-6	151	21.9	133	19.3	133.6	19.4	127	18.4	306	44.4	556	80.6	252	35.5	265	38.4	372	54.0	387	56.1	352	51.1	414	60.0
-4	169	24.5	151	21.9	152	22	145	21.0	334	48.4	601	87.2	278	40.3	293	42.5	404	58.6	420	60.9	383	55.5	448	65.0
-2	187	27.1	171	24.8	171.7	24.9	164	23.8	365	52.9	648	94.0	306	44.4	322	46.7	437	63.4	455	66.0	416	60.3	485	70.3
0	207	30.0	191	27.7	192.4	27.9	184	26.7	396	57.4	697	101.1	336	48.7	353	51.2	472	68.5	493	71.5	450	65.3	524	76.0
2	226	33.1	213	30.9	214.5	31.1	205	29.7	429	62.2	749	108.6	367	53.2	386	56.0	508	73.7	532	77.2	487	70.5	564	81.8
4	250	36.3	236	34.2	237.8	34.5	227	32.9	464	67.3	803	116.5	400	59.0	420	60.9	547	79.3	572	83.0	525	76.1	606	87.9
6	273	39.6	260	37.7	262.3	38	250	36.3	501	72.7	860	124.7	434	62.9	457	66.3	587	85.1	615	89.3	565	81.9	651	94.4
8	297	43.1	286	41.5	288.3	41.8	275	39.9	539	78.2	919	133.3	471	68.3	495	71.8	628	91.1	660	95.7	606	87.9	697	101.1
10	322	46.7	313	45.4	315.6	45.6	301	43.7	579	84.0	962	142.4	509	73.6	534	77.5	672	97.5	707	102.5	650	94.3	746	106.2
12	348	50.5	341	49.5	344.4	49.9	328	47.6	621	90.1	1047	151.9	549	79.6	576	83.5	717	104.0	756	109.8	696	100.9	797	115.5
14	376	54.5	371	53.8	374.6	54.3	357	51.8	665	96.5	1115	161.7	591	85.7	620	89.9	765	111.0	808	117.2	744	107.9	850	123.3
16	404	58.6	402	58.3	406.4	58.9	387	56.1	711	103.1	1166	172.0	636	92.2	666	96.6	814	116.1	862	125.0	794	115.2	905	131.3
18	434	62.9	435	63.1	439.6	63.8	419	60.8	759	110.1	1260	182.7	682	98.9	715	103.7	865	125.5	918	133.1	846	122.7	953	139.7
20	466	67.6	470	68.2	470.4	68.2	452	65.6	808	117.2	1338	194.1	731	106.0	765	111.0	916	133.1	976	141.6	900	130.5	1023	148.4
22	496	72.2	506	73.4	508.2	73.7	487	70.6	860	124.7	1416	205.7	761	113.3	816	116.6	974	141.3	1037	150.4	957	138.8	1066	157.5
24	533	77.3	544	78.9	556.6	80.7	524	76.0	915	132.7	1502	217.8	835	121.1	873	125.6	1031	149.5	1101	159.7	1016	147.4	1151	166.9
26	568	82.4	583	84.6	594.7	86.3	562	81.5	971	140.8	1590	230.6	890	129.1	931	135.0	1091	158.2	1167	169.3	1078	156.4	1219	176.8
28	605	87.7	625	90.6	622.7	90.3	602	87.3	1029	149.2	1681	243.6	940	137.5	991	143.7	1159	167.2	1236	179.3	1142	165.0	1290	187.1
30	643	93.3	668	96.9	650.6	94.4	644	93.4	1090	158.1	1776	257.6	1009	146.3	1054	152.9	1218	176.7	1308	189.7	1208	175.2	1364	197.8
32	683	99.1	713	103.4	698.4	101.3	687	99.6	1154	167.4	1874	271.8	1072	155.5	1119	162.3	1284	186.2	1382	200.4	1278	185.4	1440	208.9
34	725	105.2	761	110.4	746.2	106.2	733	106.3	1219	176.6	1976	286.6	1136	165.1	1166	172.3	1359	196.2	1460	211.6	1350	195.0	1520	220.5
36	768	111.4	810	117.5	792.1	114.9	781	113.3	1288	186.8	2082	302.0	1206	174.9	1259	182.6	1425	206.7	1540	223.4	1424	206.5	1602	232.4
38	813	117.9	861	124.9	836.1	121.3	830	120.4	1359	197.1	2193	318.1	1278	185.4	1333	193.3	1499	217.4	1624	235.5	1502	217.8	1688	244.8
40	859	124.6	915	132.7	880.2	127.7	882	127.8	1432	207.7	2307	334.6	1352	196.1	1411	204.6	1576	226.6	1711	246.2	1583	229.6	1777	257.7
42	907	131.5	970	140.7	926.9	134.4	936	135.8	1508	218.7	2426	351.9	1430	207.4	1491	215.3	1655	240.0	1800	261.1	1666	241.6	1869	271.1
44	957	138.8	1028	149.1	976.6	141.6	982	143.9	1587	230.2	2549	369.7	1510	219.0	1575	226.4	1737	251.9	1894	274.7	1753	254.3	1964	284.9
46	1009	146.3	1089	157.9	1026	146.8	1051	152.4	1669	242.1	2676	388.1	1594	231.2	1663	241.2	1822	264.3	1990	288.6	1842	267.2	2063	299.2
48	1062	154.0	1151	166.9	1078.3	156.4	1111	161.1	1753	254.3	2808	407.3	1681	243.8	1754	254.4	1909	276.9	2090	303.1	1935	280.6	2165	314.0
50	1118	162.2	1216	176.4	1129.5	163.8	1174	170.3	1841	267.0	2945	427.1	1772	257.0	1849	268.2	2000	290.1	2194	318.2	2031	294.6	2271	329.4
52	1175	170.4	1284	186.2	1193.2	173	1240	179.8	1931	280.1	3085	447.5	1865	270.5	1948	282.5	2094	303.7	2301	333.7	2131	309.1	2381	345.3
54	1234	179.0	1354	196.4	1248.5	181.1	1308	189.7	2025	293.7	3233	468.9	1963	284.7	2051	297.5	2190	317.6	2412	349.8	2234	324.0	2494	361.7
56	1295	187.8	1427	207.0	1312.4	190.3	1379	200.0	2122	307.8	3384	490.8	2064	299.4	2158	313.0	2290	332.1	2526	366.4	2341	339.5	2612	378.8
58	1359	197.1	1502	217.8	1381.1	200.3	1453	210.7	2222	322.3	3541	513.6	2169	314.6	2270	329.2	2393	347.1	2644	383.5	2451	355.5	2733	396.4
60	1424	206.5	1581	229.3	1449.5	210.2	1529	221.8	2325	337.2	3703	537.1	2278	330.4	2367	346.2	2500	362.6	2767	401.3	2564	371.9	2858	414.5

Red figures under kPa are minus kilopascals Red figures under psi are inches of mercury

NOTE: Measurement of static pressures may vary slightly from tabulated figures for any refrigerant blend

## Freezing Point Chart

Freezing point (°C)	Ethylene Glycol (% Weight)	Propylene Glycol (% weight)
-5	14.0	15.2
-10	23.6	25.0
-15	30.5	33.0
-20	36.2	39.0
-25	41.1	44.0
-30	45.4	48.0
-35	49.3	51.0
-40	52.8	54.0



Add : S/F-16, OMKAR COMPLEX, VALIA CHOKDI, GIDC, ANKLESHWAR, GUJARAT, INDIA - 393002

Contact: +91 9137077904 Email: fitzerincorporation@gmail.com Website: www.fitzerincorporation.com