

FINNED TUBES & HEAT EXCHANGERS

FITZER
INCORPORATION
SINCE 1986



www.fitzerincorporation.com

FITZER INCORPORATION, is engage in the field of Design, Manufacturing & Exporting various types of such as, Extruded finned tube, Serrated finned tube, Spiral finned tube, Crimped finned tube, wire wound finned tube, Helical finned tube, welded finned tube, H' type finned tube, Economizer coil, Spiral type Heat exchanger, Finned Tube Heat Exchangers, Oil coolers Fin Fan Coolers Process Gas Cooler, Air Heater, Air Pre Heaters, , Hydraulic oil coolers, Air Cooled Heat Exchangers & various types of Shell & Tube Heat exchangers / Evaporators / Condensers, Industrial Dehumidifiers, Blowers & Evaporative Condenser

Other Products: - Block Ice Plant, Tube Ice Plants, Flake Ice Plants.

Our brand chooses to stand firm in the Indian & International market with promise, Standard & guarantee. Established by two technocrats vast experience in Stainless Steel Fabrication, Thermal Heat Transfer Systems & Refrigeration HVAC equipment

Our team result oriented Qualified Techno-Commercial Staff having spirit of team work, enthusiasm and a passion for excellence to deliver outstanding performance in the field of manufacturing GMP and Non GMP Equipments for Chemical, Pharmaceutical, Paints and Other Process Industries. We design and manufacture as per international standard such as ASME / TEMA

Our products can be seen operating in refineries & petrochemical, pharmaceutical, chemical, marine, steel & various process industries.

Our products have exported our products to Africa, Middle East & Asian countries
Our Quality Control facilities include trained personnel and calibrated instruments

WIRE FINNED TUBE

FITZER Products is the INDIA's largest manufacturer of wire fin tubes. Our wire fin tubing is found all over the India in a wide range of applications. The major uses for wire finned tubes are in heat recovery associated with boilers, gas turbines for power generation and in furnace applications for the petrochemical Industry.

Our wire finned tubes are helically wound using specialized high-quality brazing techniques and may have plain or serrated fin types.

These finned tubes have fins made of wire instead of strips. Continuous loops of wire are formed and are continuously soldered to the circumference of the tube to ensure 100% contact. Loops per turn and turns per foot can be altered as per surface area requirements. Due to continuous soldering of wire loops these finned tubes offer a very high heat transfer efficiency with less air pressure drop. Used in air cooled Oil Coolers in thermo Pac units and also used for Air Heating applications.

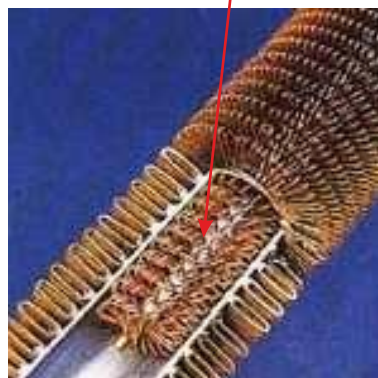
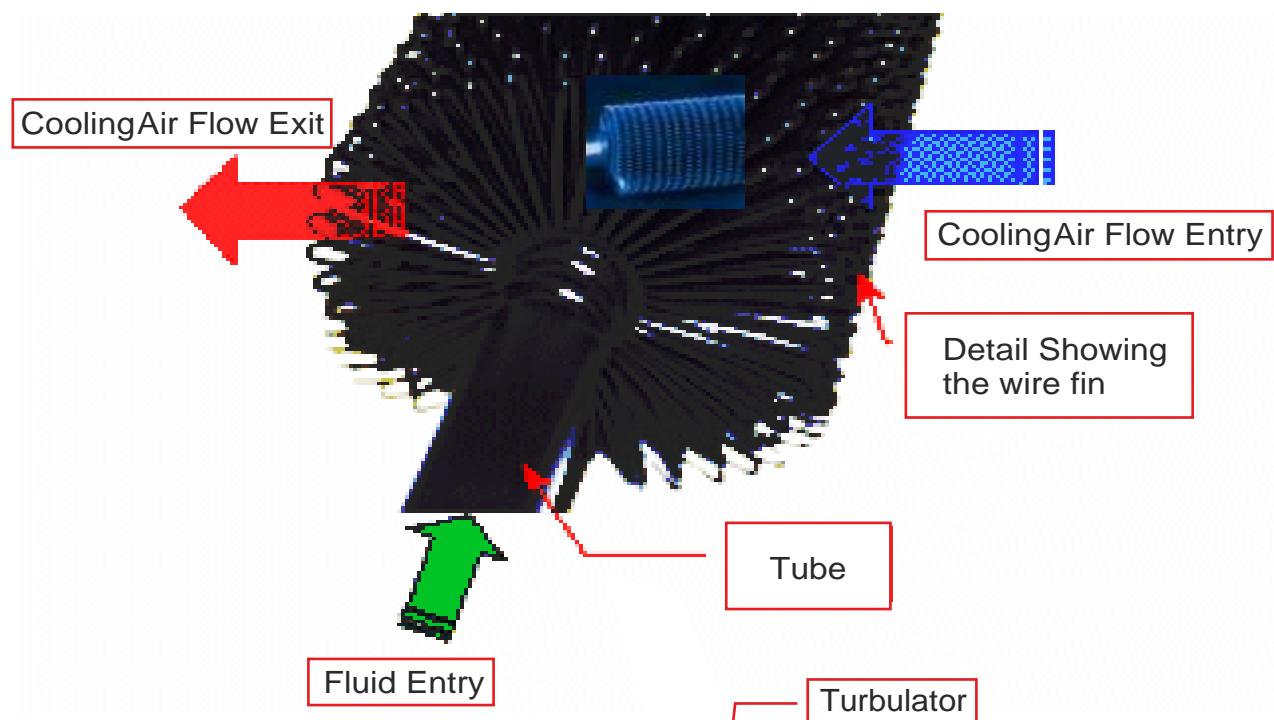

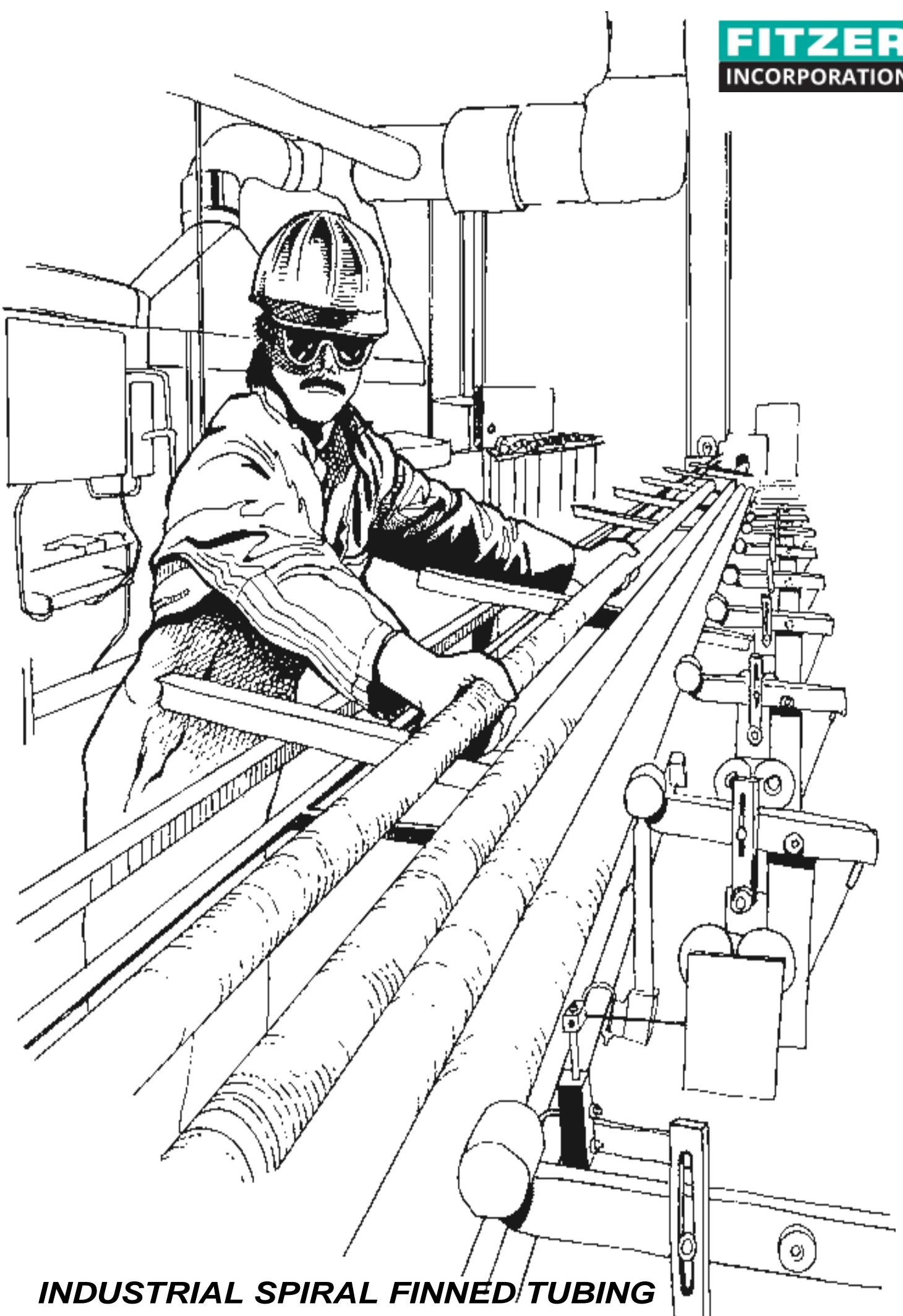

INDUSTRIAL SPIRAL FINNED TUBING
Manufacturing Waste Heat Transfer Products to Save Energy

SPIRAL FINNED TUBE

FITZER Products is the INDIA's largest manufacturer of spiral surface tubing. Our spiral finned tubing is found all over the India in a wide range of applications. The major uses for spiral finned tubes are in heat recovery associated with boilers, gas turbines for power generation and in furnace applications.

Our spiral finned tubes are wound using specialized high- quality brazing techniques and may have plain or serrated fin types. We have vast expertise and more than 57 years' experience in this field.

These types of fins are semi-crimped and wrapped under tension around the outside of the base tube. Fins are either tack welded or crimped to the base tube at each end of the tube. These finned tubes can be further HOT DIPPED GALVANISED for surface protection where as the deposition of Zinc also adds up to the efficiency of finned tubes.

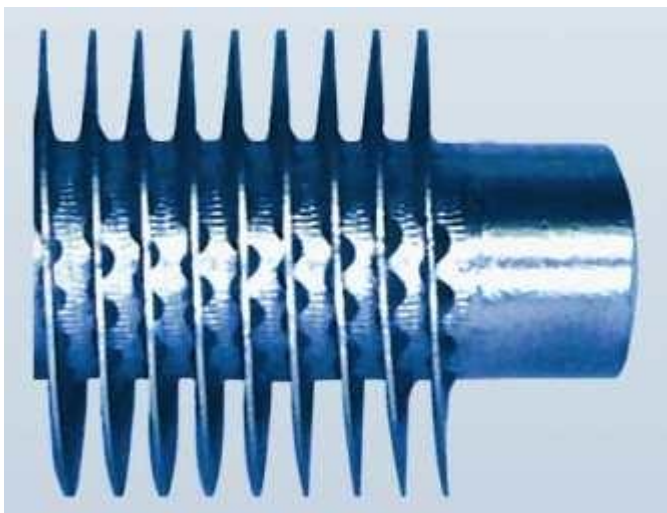
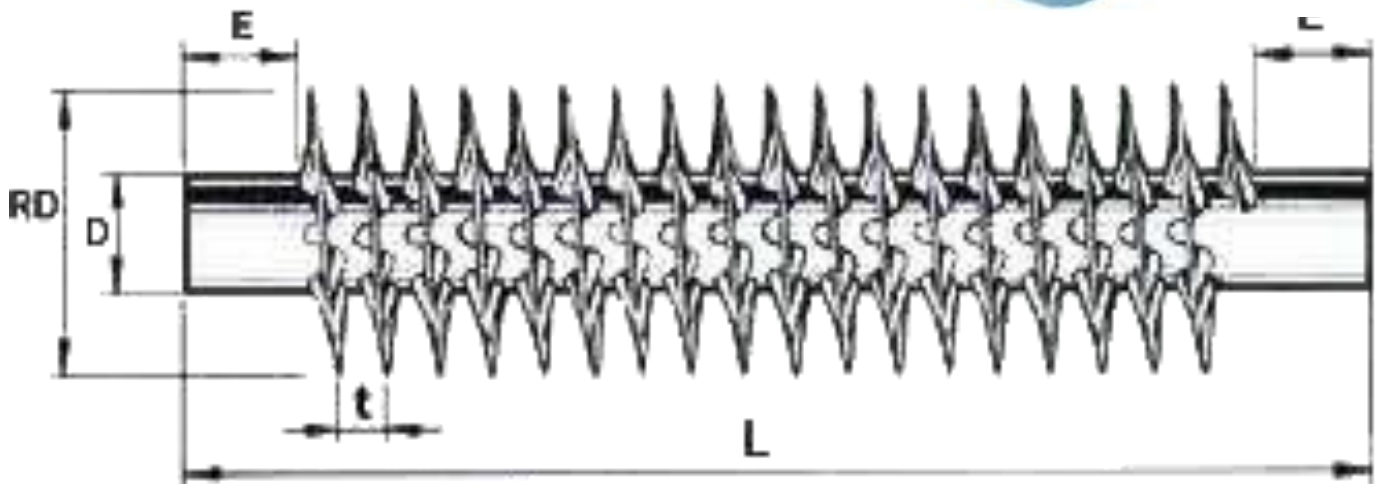



WELDED FINNED TUBE

FITZER Products is the INDIA's largest manufacturer of extended surface tubing. Our welded/brazed finned tubing is found all over the India in a wide range of applications. The major uses for welded/brazed finned tubes are in heat recovery associated with boilers, gas turbines for power generation and in furnace applications for the petrochemical industry.

Our finned tubes are helically wound using specialized high-frequency welding techniques and may have plain or serrated fin types.

Our pre-eminence in this kind of work enables us to offer customers:

- Short lead times
- An extensive range of material combinations for customized applications
- Exceptional quality standards

Solid/Plain Fin Type



Serrated Fin Type

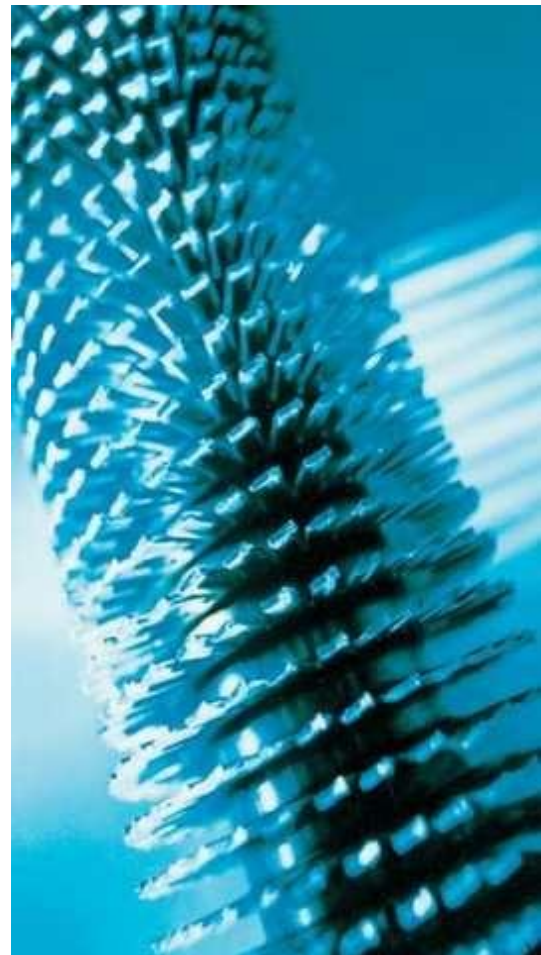

PRODUCT SPECIFICATION

Our machines are capable of handling tube/pipe sizes from 25mm O/D to 350mm O/D in carbon, alloy and stainless steels, as well as high nickel alloys. Fin sizes range from 10mm to 50mm high and from 0.8mm to 3.5mm thick in carbon steel, stainless steels (300 and 400 series) and high nickel alloys.

QUALITY

The FITZER name is a guarantee of high standards. We supply finned tubes in accordance with the international standard for dimensions, tolerances and test of HF resistance welded fins. We have also supported the setting up of an ASTM standard for HF-welded finned tubes. FITZER not only works within all international quality standards, in many cases it established those standards through its own quality leadership.

CORROSION PROTECTION

If required, the external surfaces of finned tubes can be treated with corrosion-resistant fluids.

WORLDWIDE AVAILABILITY

We dispatch tubes throughout the world by road, rail, container or ship, and can offer a full export packing service on request.

AN EXCEPTIONAL SERVICE

In addition to manufacturing extended surface tubing, our company FITZER Fin Tube can incorporate it into the heat recovery system and supply it as a complete unit. As with our tube manufacturing processes, they work to recognized BS and ASME quality standards, employing highly-skilled certified welders and operating to stringent guidelines. We believe the expertise and experience available to FITZER Fin Tube Products in this field are unique, and are confident that major operators will find this a quite exceptional service.

Solid/Plain Fin Type

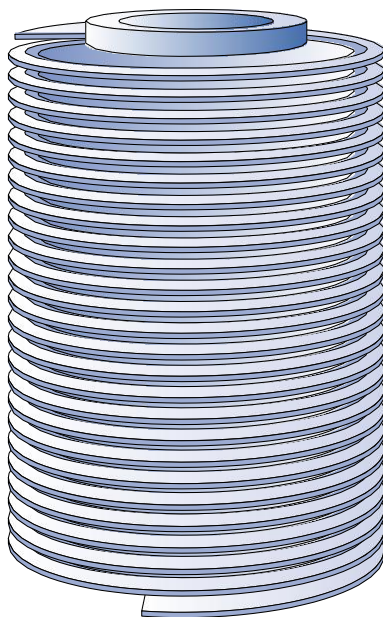

Serrated Fin Type

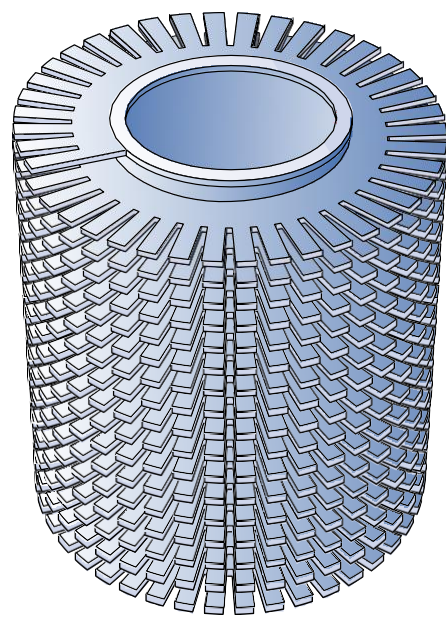

EXPERTISE IN KEY PROCESSES

The processes involved in creating high frequency resistance welded finned tubing raise a number of interesting technical demands to which we bring highly specialist expertise and long experience of this kind of work.

For the benefit and interest of plant operators, we outline below some of the issues involved in:

- Resistance welding
- Weld quality
- Minimizing pressure drop

RESISTANCE WELDING

High-frequency resistance welding usually employs a current of 450,000 Hz. With this technique, the fin is edge wound encircling the tube to give a continuous weld.

The forming of the fin around the tube and the heat of welding causes some upsetting or widening of the base of the fin, resulting in a contact area wider than the fin itself.

Here again, the function of the weld is to maintain the contact between the fin and the tube. Heat is thus transferred across the whole interface and not just through the weld itself. However, the quality of the HF weld is more important in maintaining negligible resistance to heat transfer between the fin and tube.

The use of high-frequency current results in very localized heating of the tube surface and the edge of the fin. This skin effect produces higher weld speeds and greater ease in welding difficult material combinations.

The HF process also allows much thicker fins to be welded. In fact, it is now possible to weld fins heavy enough to replace those previously available only with MIG, TIG and stud-welding processes, which are generally more expensive and require post-weld heat treating.

The HF process involves the use of heat and pressure to obtain coalescence of the fin and tube. An electric current is applied by contacts on the fin and tube, and the resistance in this circuit produces the heat necessary for welding.

Maximum resistance and therefore maximum heating occur at the interface between the fin and the tube. Pressure is applied by various forms of tooling to forge the fin and the tube together at the point of maximum heating.

The resistance welding process produces a strong metallurgical bond between the fin and the tube while minimizing the heat-affected zone (HAZ) in the tube.

The use of pressure to forge the fin and the tube together helps to minimize the heat input necessary to make the weld. In addition, the HF process allows the whole weld area to be continuously water-drenched which keeps the tube cool, except in the immediate area of the weld.

As a result, most common tube materials show little changes in grain structure or physical properties when fins are welded to them.

The most notable exceptions to this are the 3% to 9% chromium steels which change from a ferrite to a martensitic microstructure in the heat-affected zone, with a significant increase in hardness

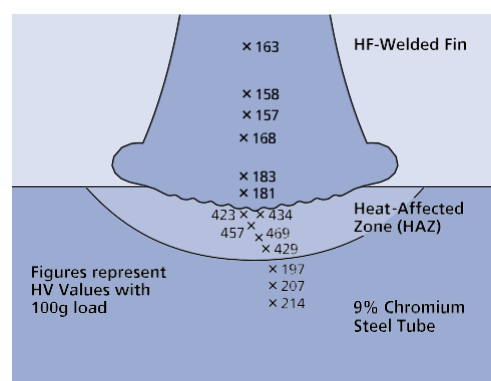

The diagram above is a hardness study for a 9% chromium steel tube with HF-welded fins. The heat-affected depth is minimal when compared with other types of welding.

Post-weld heat treatment of HF-welded fins is not considered necessary for satisfactory service, even in the extreme case shown above, because of the superficial nature of the changes in the microstructure.

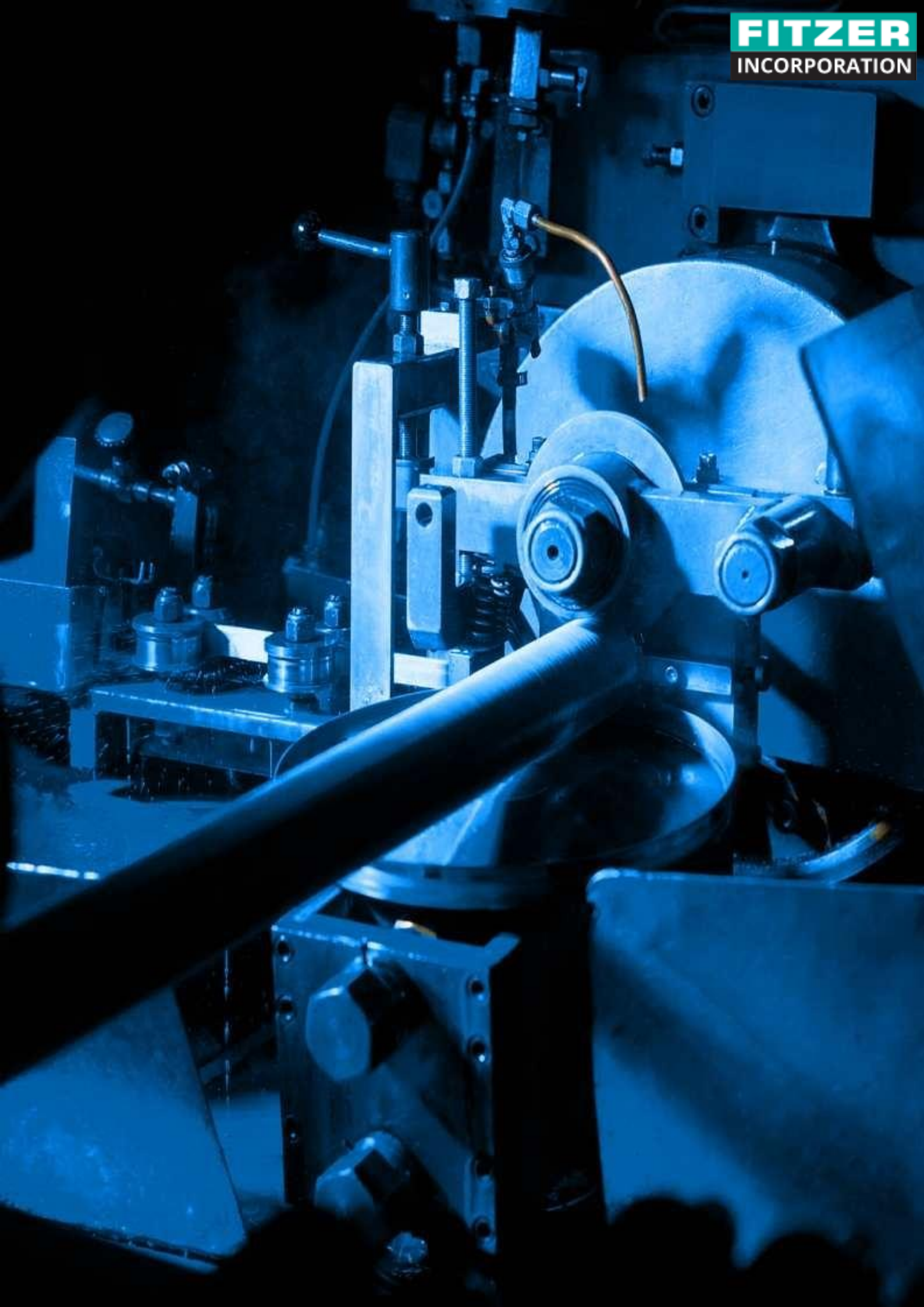

APPLIED FINNED TUBES

THE TYPES OF FINNED TUBE

We supply four types of applied finned tubes, as well as the higher specification extruded tube, used for more demanding applications.

APPLIED FINNED TUBES

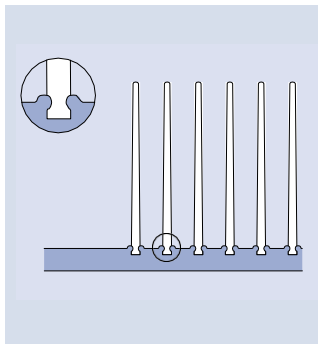

in
(Embedded
Fin)

Application: High-efficiency fin for high operating temperatures
Upper limiting temperature: 450°C
Manufacture: A helical groove is formed in base tube displacing of material and fin is wound into the groove under tension, followed by backfilling of the displaced material to lock the fin root into the tube
Fin materials: Aluminum
Base tube materials: Any readily machinable material

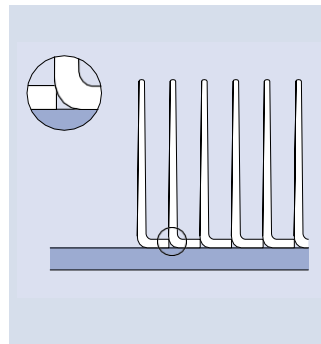

L Fin
(Wrapped Fin)

Application: Standard fin for low-temperature application where some degree of tube wall protection is required
Upper limiting temperature: 180°C
Manufacture: Fin foot is pre-formed into L shape and applied to base tube under tension. The adjacent fins abut one another, giving a degree of base tube protection for less aggressive environments
Fin materials: Aluminum
Base tube materials: Any metallic material

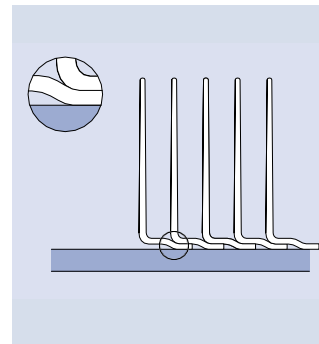

LL Fin
(Overlapped L Fin)

Application: Standard fin for low-temperature applications giving increased atmospheric corrosion protection of the base tube
Upper limiting temperature: 200°C
Manufacture: Fin foot is pre-formed into an LL shape (overlapped LL) and applied to base tube under tension. However, foot is pre-shaped to give overlap of one foot onto another, thereby improving base tube protection and thermal contact area
Fin materials: Aluminum
Base tube materials: Any metallic material

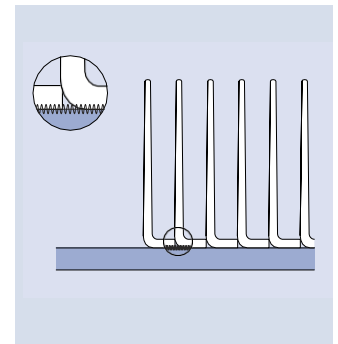

KL Fin
(Knurled L Fin)

Application: Standard fin for medium-temperature Applications, giving increased atmospheric corrosion protection to the outer surface of the base tube
Upper limiting temperature: 280°C
Manufacture: Fin foot is pre-formed into an L shape and applied to base tube under tension. Knurling tools both precede and follow the laying down of the fin foot so that the fin material is locked into the pre-knurled tube. This gives up to 50% greater thermal contact area than standard L fin and also ensures an airtight fin to tube bond, resulting in greater tube protection
Fin materials: Aluminum
Base tube materials: Any metallic material

EXTRUDED FIN TUBE

FITZER Fin Tube is the INDIA's premier manufacturer of Finned Tubes for air cooled/fin tube heat exchangers. Because good quality cooling water is either too costly or unavailable, such exchangers are relied upon heavily by most process and power generation plants throughout the world.

The heart of the fin tube heat exchanger is the extended surface – the section where heat is transferred. This surface is composed of helical high-finned tubes which need to be replaced from time to time due to corrosion, fouling or damage – either to the fins or to the base material.

Finned tubes are supplied in either applied or extruded form. Their differences are detailed in the following pages. We can supply replacement finned tubes to suit your planned shutdowns or for emergency use.

EXTRUDED FINS

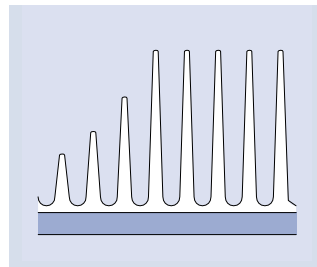

G-Extruded Fin (Bi-metallic Fin)

Application: High-efficiency fins for higher temperature applications giving complete and permanent atmospheric Corrosion –protection of the base tube. Using over 40% more aluminum than the equivalent applied fin, the extended fin is very robust and resistant to

Mechanical damage, allowing the finned tubes to be cleaned without damage using either steam or high-pressure water
Upper limiting temperature: 325°C

Manufacture: A carefully decreased core tube fitted into an aluminum primary tube. This assembly is then fed into the triple-spindle fining head of the fin-extruding machine.

Three special multi-disc packs extrude the aluminum tube into helical high fins while reducing the inner diameter to give firm

Pressure contact with the core tube

Fin materials: Aluminum

Base tube materials:

Any metallic material

Extruded Finning Machine



FINNED TUBES

FITZER Fin Tube is the Indian company to manufacture Wire, Spiral, Welded, Applied and Extruded Finned Tubes, FITZER has the ability to manufacture high-specification tube from 25mm to 350mm diameter for uses in process/ engine Coolers, Boilers, Furnaces and Industries.

Using FITZER to manufacture your finned tubes will guarantee that you receive a high-quality product, delivered on time at a highly-competitive price.

Spiral Finning Machine



Wire Finning Machine



Welded Finning Machine



Applied Finning Machine



Extruded Finning machine



QUALITY

When you place your order with FITZER Fin Tube you can be confident in the fact that we have your best interest in mind at all times. Quality issues begin as soon as your order is booked and are constantly monitored through completion by people whose experience is measured in years.

Your order is compared to documentation for accuracy. The shop order drawings receive multiple checks before issuance. Materials are inspected upon receipt for accuracy & condition. Checks are completed on every item. Inspector's monitor & record these measurements during production. Inspection by customer prior to shipment is welcomed. Shipping arrangements are made and a photo taken of each outgoing load. If at any time a question should arise during this process, the customer is notified immediately.

FITZER Fin Tube is totally committed to the requirements of its customers. Our Quality Control System is for the control of shop fabrication of Heat Exchangers, Finned Tubing, and Coils. Our system is based on the ASME standard for heat exchanger design. May it be ISO, ASME, ASTM, TEMA, or other customer specified system we can adapt our system to meet your requirements. FITZER Fin Tube's system includes accurate document control. This means your job is inspected and reported in every stage of manufacturing.

RECEIVING:

Whether the component parts are customer consigned or FITZER Fin Tube supplied each is inspected to ensure they meet material specification, dimensional specifications, and physical count.

FIRST ARTICLE INSPECTION:

The first production run piece from each lot is inspected to customer print.

IN PROCESS INSPECTION:

Machine operators and Quality Control Inspectors check parts throughout run. Dimensional check fixtures and gages are used when necessary.

FINAL INSPECTION:

When the fabrication or assembly of a job item is complete, the Quality Control Inspector will make the final inspection and initial/date the Work Order when the item meets the job requirements.

PRODUCT RELEASE:

Quality Control inspects packaging, checks quantity, assembles certifications and signs off for product release.

Quality and Customer Satisfaction is not only a decision it is our company policy. **FITZER** Fin Tube looks forward to providing excellent quality product to fit your needs.

TYPICAL APPLICATIONS

The wide range of uses for helical high-finned tubes includes:

- Steam condensers
- Oil coolers
- Air pre-heaters
- Water coolers
- Overhead condensers
- Product coolers – gas, chemicals, petrochemicals, oil etc

Our Finning machines are recognized as the most efficient and reliable for the manufacture of applied finned tubes.

Using **FITZER** to manufacture your finned tubes will guarantee that you receive a high-quality product, delivered on time at a highly-competitive price.

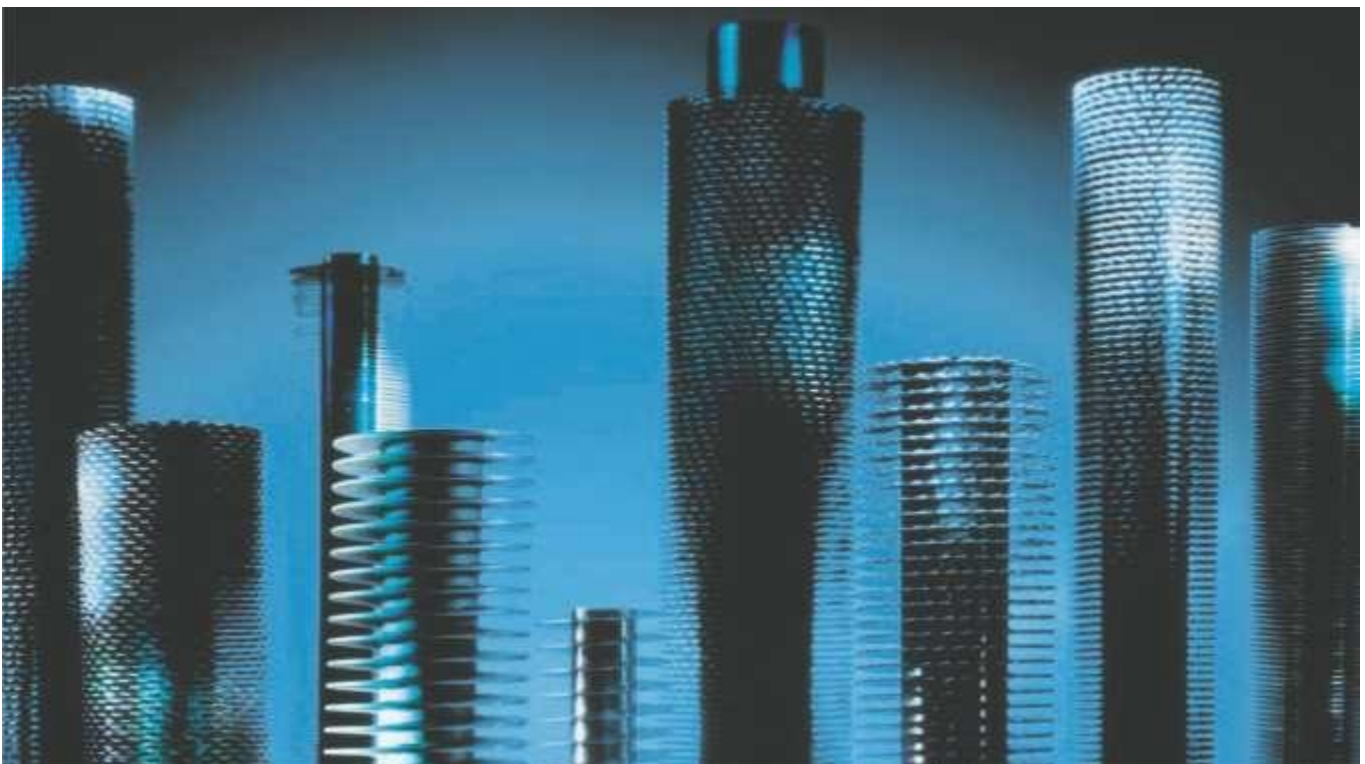

HEAT EXCHANGERS

AIR HEATER / AIR COOLER

The wide range of uses for finned tubes includes:

- Steam condensers
- Water coolers
- Product coolers :
gas, chemicals,
petrochemicals etc.
- Oil coolers
- Air coolers
- Air pre-heaters

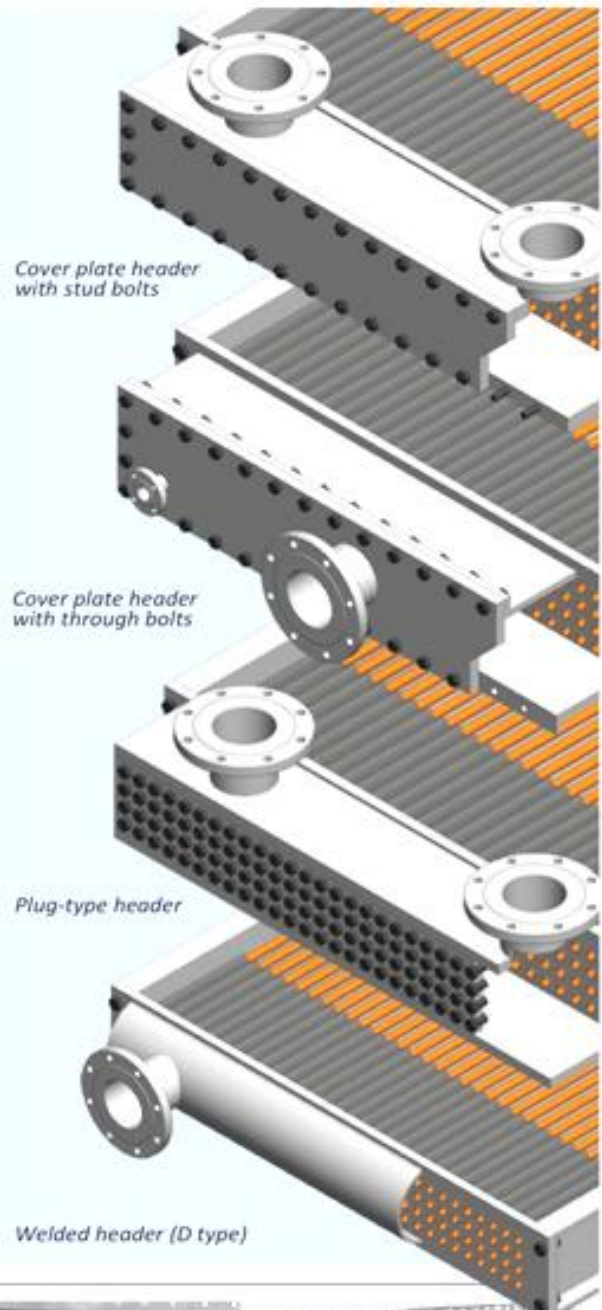
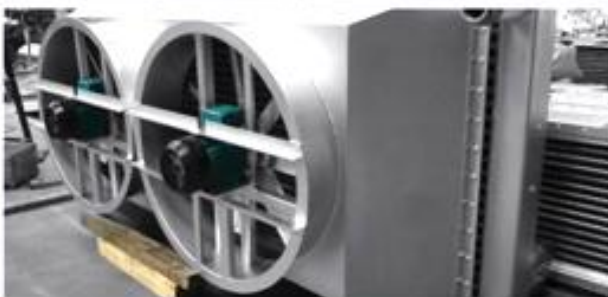



• **AIR PREHEATER FOR RICE MILL**

Air preheater are heat exchangers for heating evaporator for cooling and condensing and for heat recovery.

• **WIDE RANGE SPECIIL VARIANTS**

- Air pre cooler
- Air Heat exchanger for steam and condensate
- Heat recovery system
- Economizers waste heat

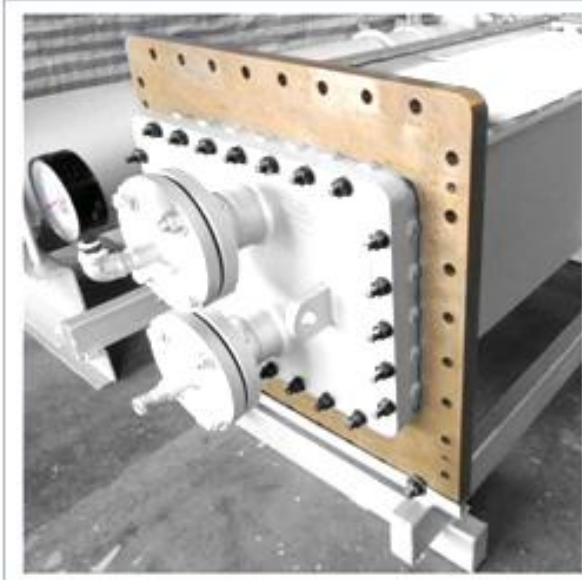

SHELL & TUBE HEAT EXCHANGERS

We manufacture shell & tube for process and other heating cooling applications.

APPLICATION WATER COOLER

- Oil Cooler
- Condensers & Evaporators for Chemical, Process
- Lube oil Cooler Power Plant
- Hydraulic System
- Process heat removal and preheating of feed water

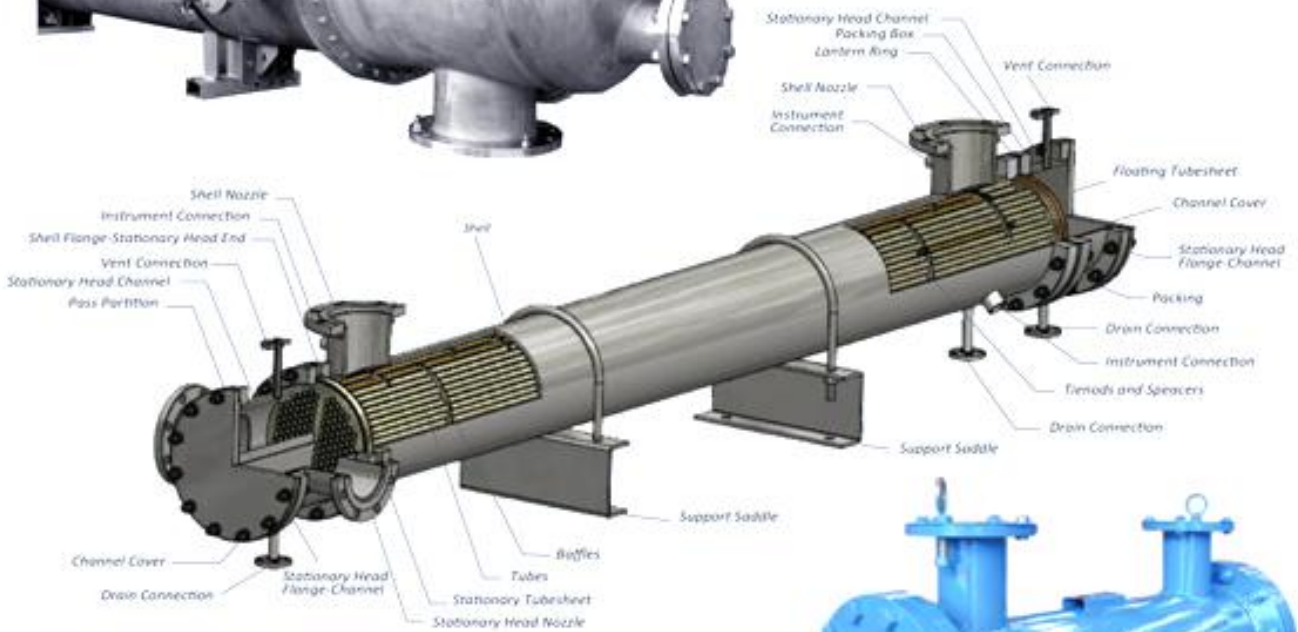

TUBE

- CuNi 90/10
- CuNi 70/30
- Stainless Steel grade 304/316
- Carbon Steel A179
- DUPLEX



PROJECT REFERENCE

- Finned Tubes
- Compact Heat Exchangers
- Air Heater/ Air Cooler
- Shell & Tube Heat Exchangers



Shell & Tube Heat Exchangers



Air Heater/ Air Cooler

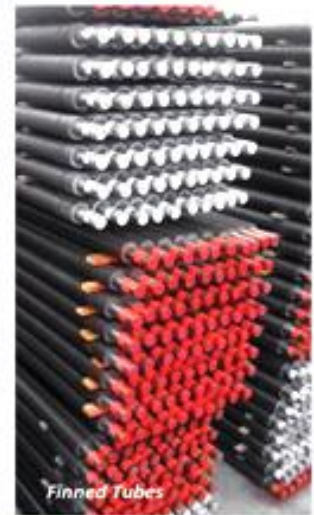

Finned Tubes



Finned Tubes



Shell & Tube



Air Heater/ Air Cooler



Shell&Tube Heat Exchangers



Air Heater/ Air Cooler

FITZER INCORPORATION

Add: S/F-16, OMKAR COMPLEX, VALIA CHOKDI, GIDC, ANKLESHWAR, GUJARAT, INDIA 393002

Contact: +91 9137077904 Email: fitzerincorporation@gmail.com

Website: www.fitzerincorporation.com