

## AV-311 F.S.S. Needle Valve (Regulating Valve), Class-800

### Features

One Piece Design, Reduced Bore, Renewable Needle Type Disc, SS Trim, Screwed Female NPT Threads as per ASME B1.20.1  
Product Standard: API-602

### Test Pressure

Body - 207 Bar (Hyd.)  
Seat - 152 Bar (Hyd.)  
Testing Standard : API-598

### Suitability

Water, Steam, Oil



### Material Combination

P.No.	Name of Part	Material	Specification
1	Body	F.S.S	ASTM A182 Gr. F304
2	Washer	Stainless Steel	ASTM A276 TYPE 304
3	Gland Packing	To Suit	-
4	Gland	Stainless Steel	ASTM A276 TYPE 304
5	Gland Nut	Stainless Steel	ASTM A276 TYPE 304
6	Stem	Stainless Steel	ASTM A276 TYPE 304
7	Handle	Stainless Steel	ASTM A276 TYPE 304

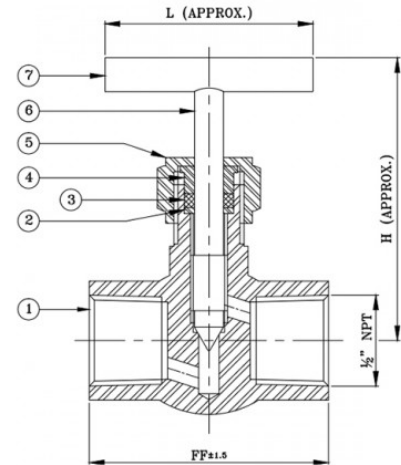

### Dimensional Data

Nominal Size (mm)	FF ±1.5	H	L
15	58	75	55