

AV-96A Cast Iron Butterfly Valve Class 125

Features

Wafer Type, Without Lugs, Renewable Liner, Suitable for insertion between flanges Flanged as per ANSI B16.1 Class 125 DIN ND-10 & BS-10 Table 'E'

Test Pressure

Body : 21 Bar (Hyd.)

Seat : 14 Bar (Hyd.)

Testing Standard

IS 13095

Note

FF dimension is from metal surfaces. Valves size 8" & above with gear arrangement.

Suitability

Water



Material Combination

P.No.	Name of Part	Material	Specification
1	Lever Assembly	Carbon Steel	-
2	Packing Ring	PTFE	-
3	Body	C.I.	IS 210 Gr. FG 200
4	Upper Stem	Stainless Steel	ASTM A276 Type 410
5	Bush	Bronze	ASMA B62
6	Body Liner	EPDM (Renewable Liner)	-
7	Disc	C.S.S.	ASTM A351 Gr. CF8
8	Lower Stem	Stainless Steel	ASTM A276 Type 410
9	O - Ring	Nitrile Rubber	-
10	Bottom Cover	C.I.	IS 210 Gr. FG 200
11	L - Key Screw	Carbon Steel	-
12	Gear Box	C.I.	IS 210 Gr. FG 200

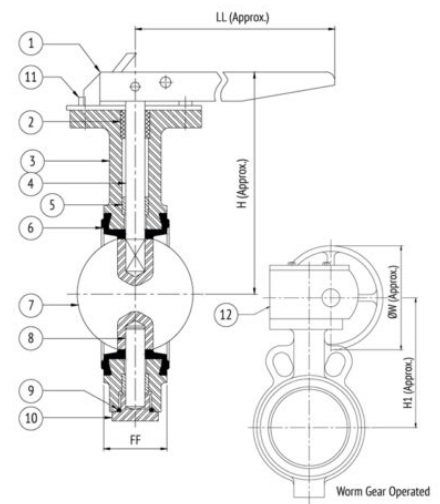

Dimensional Data

Nominal Size (mm)	FF	LL	H	H1	ØW
40	33	208	128	-	-
50	43	208	140	-	-
65	46	208	155	-	-
80	46	257	165	-	-
100	52	257	180	-	-
125	56	257	200	-	-
150	56	257	210	-	-
200	60	-	-	305	200
250	68	-	-	350	200
300	78	-	-	400	200