

**ARCHITECTURAL**

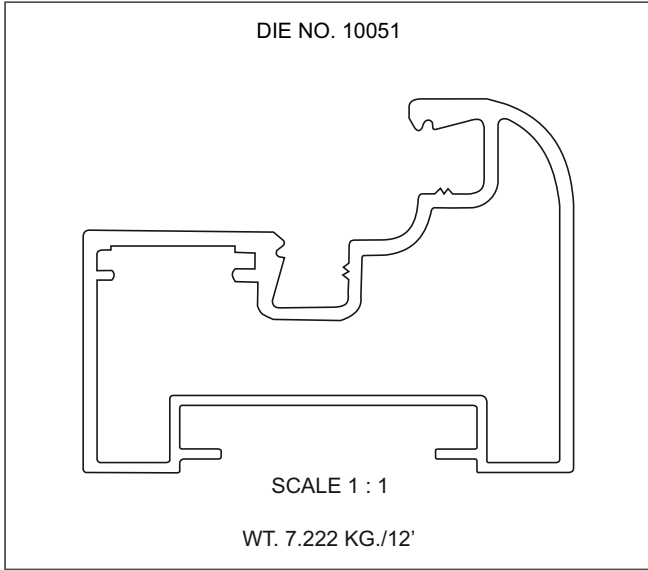

**CLEAN ROOM & OMEGA SECTION**

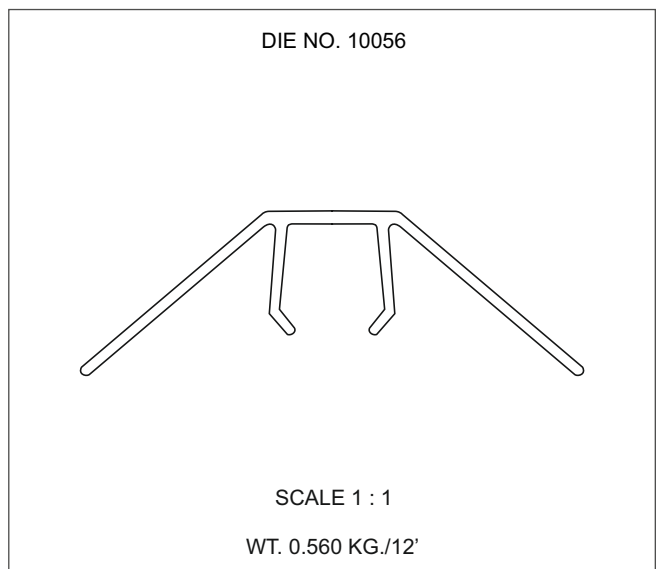
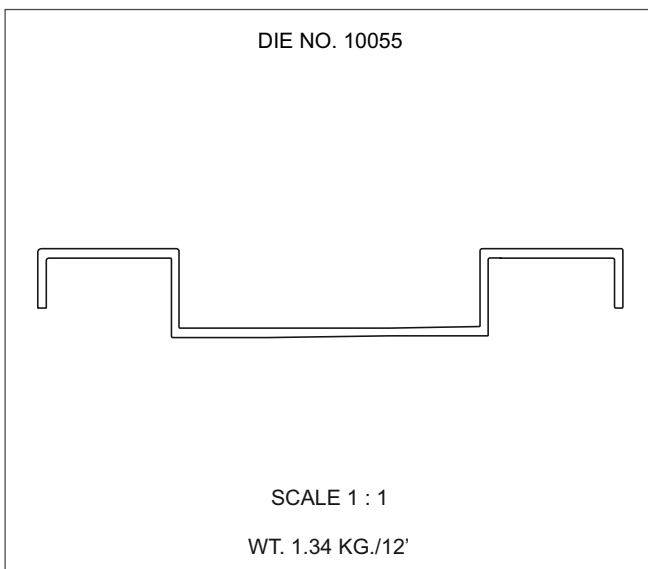
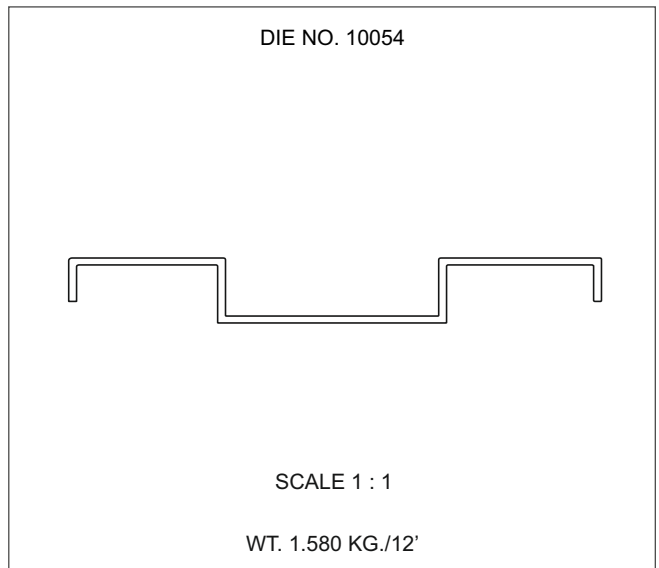
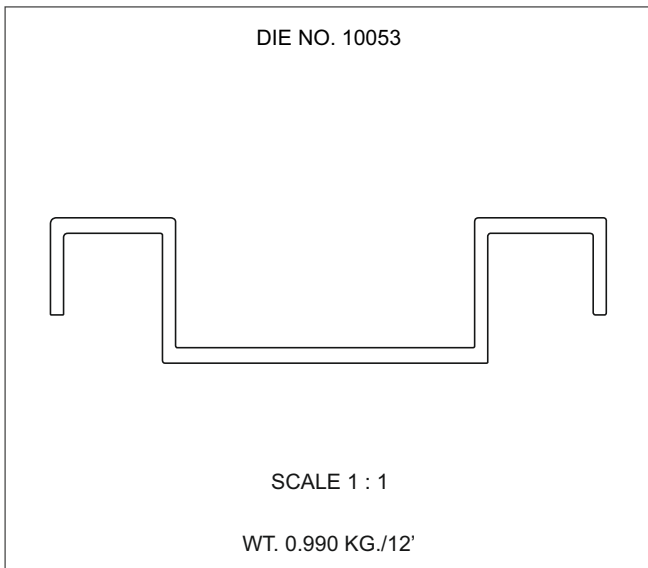
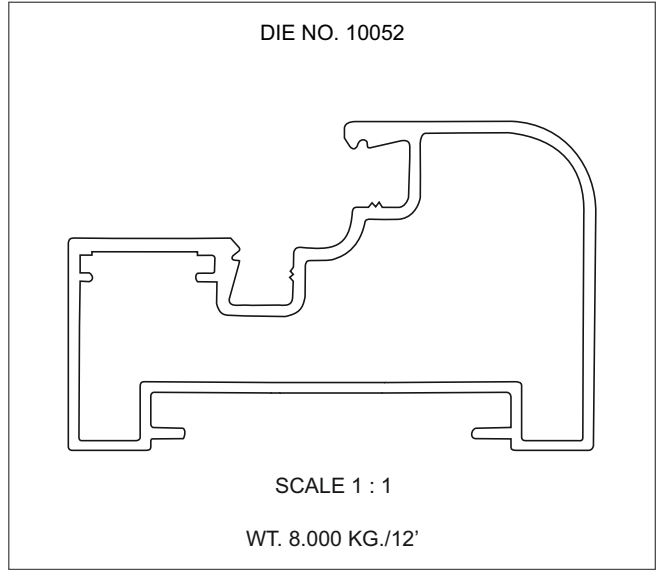

SELECTIONS NOT TO BE SCALED

ALL DIMENSIONS ARE IN MM

**ARCHITECTURAL**

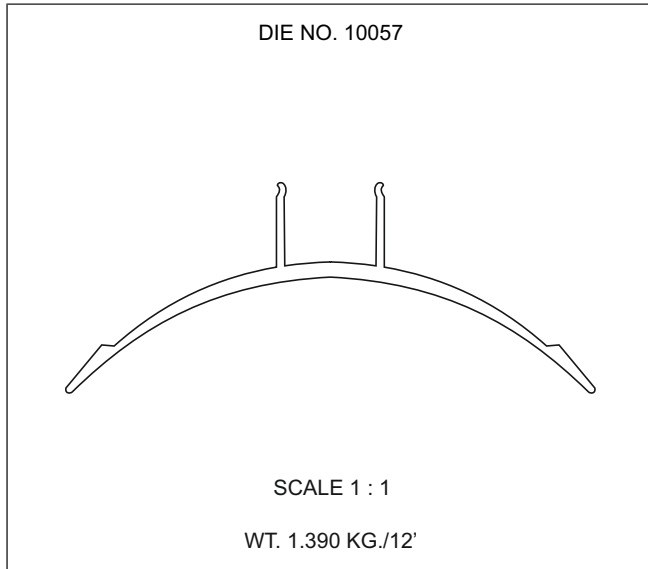

**CLEAN ROOM & OMEGA SECTION**

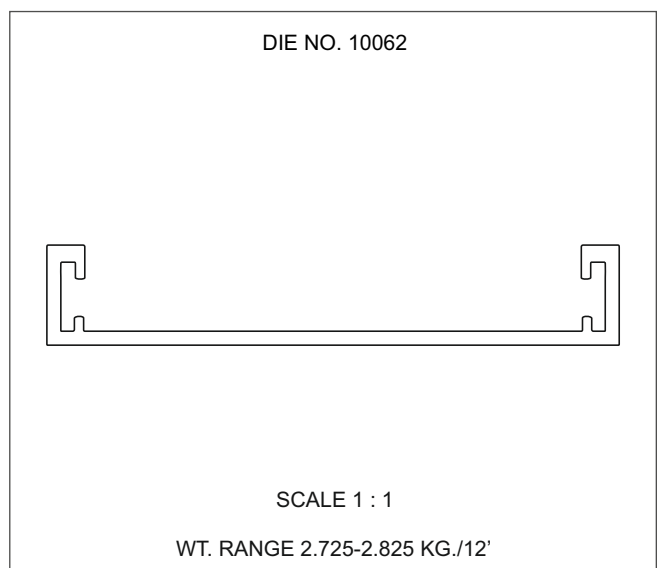
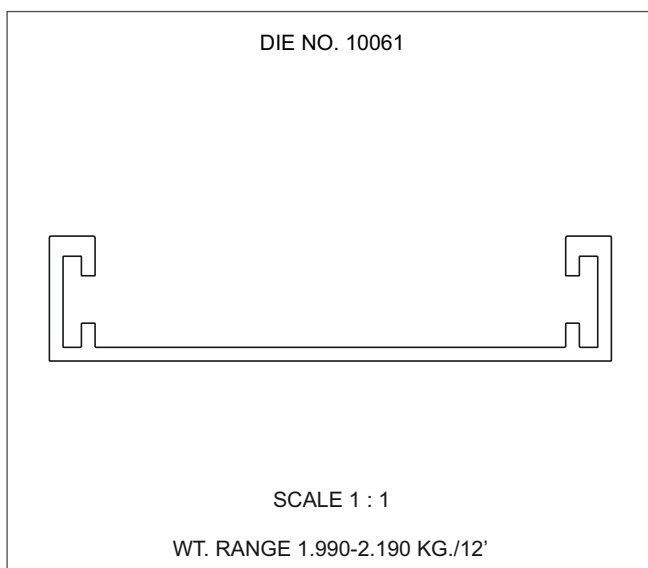
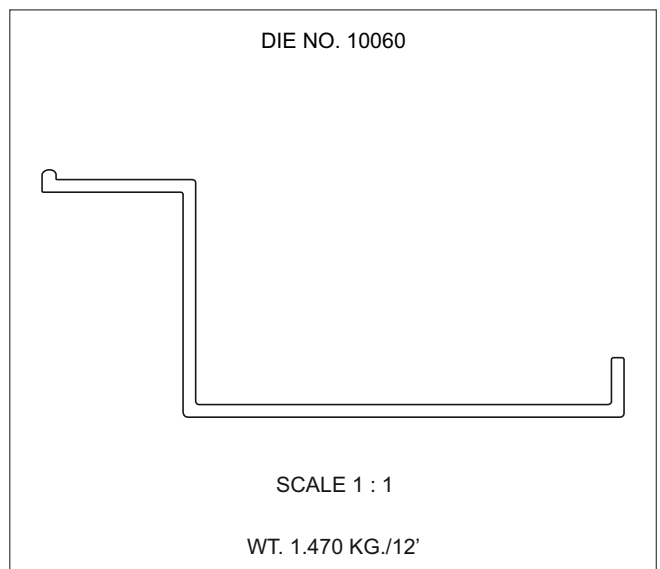
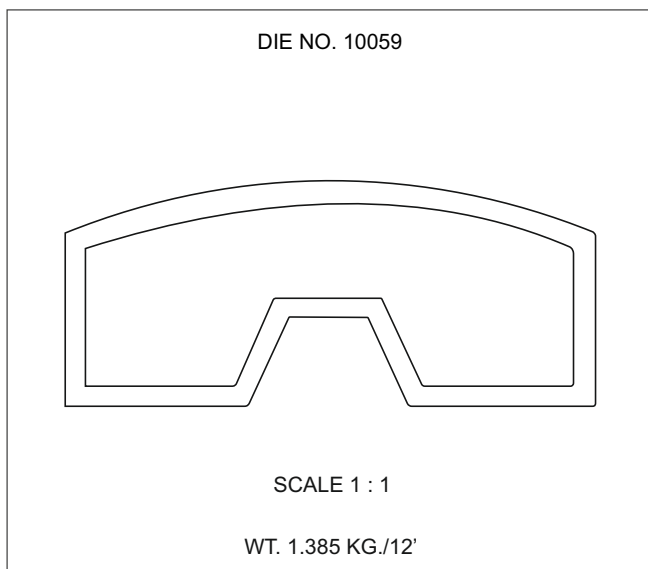
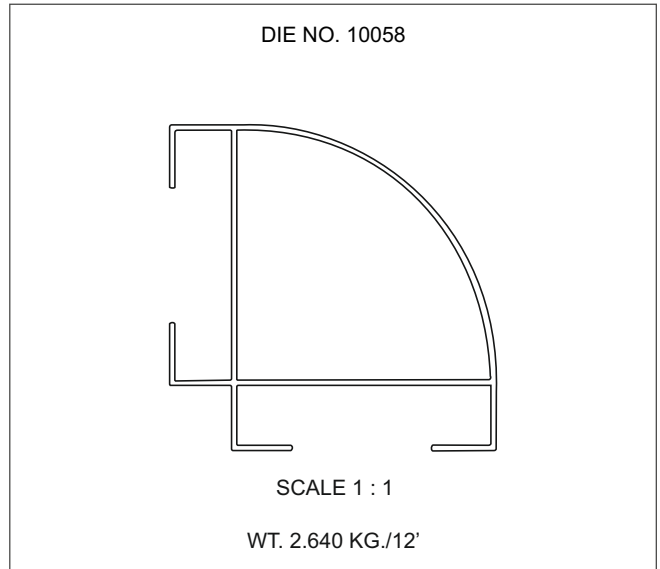

SELECTIONS NOT TO BE SCALED

ALL DIMENSIONS ARE IN MM

**ARCHITECTURAL**

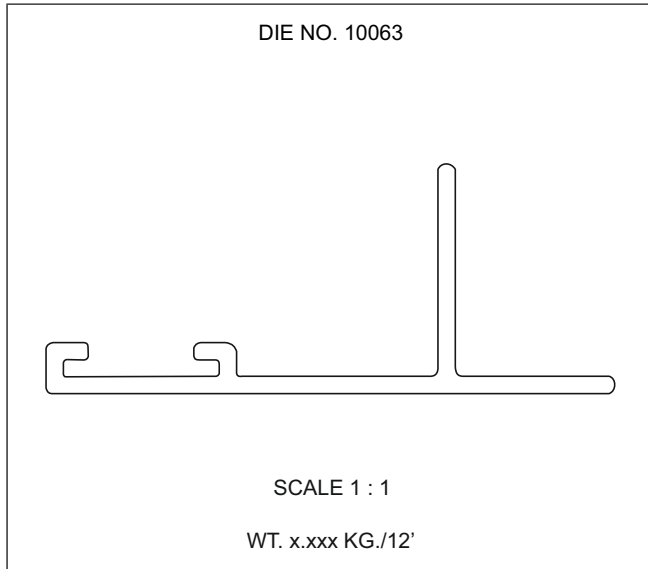

**CLEAN ROOM & OMEGA SECTION**

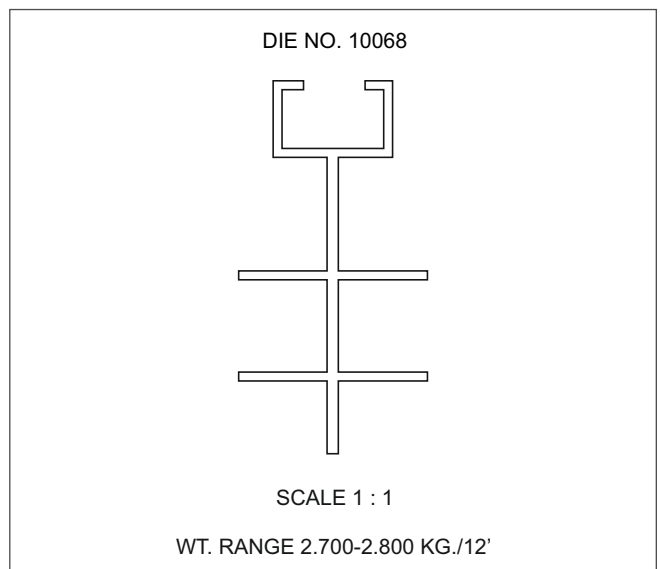
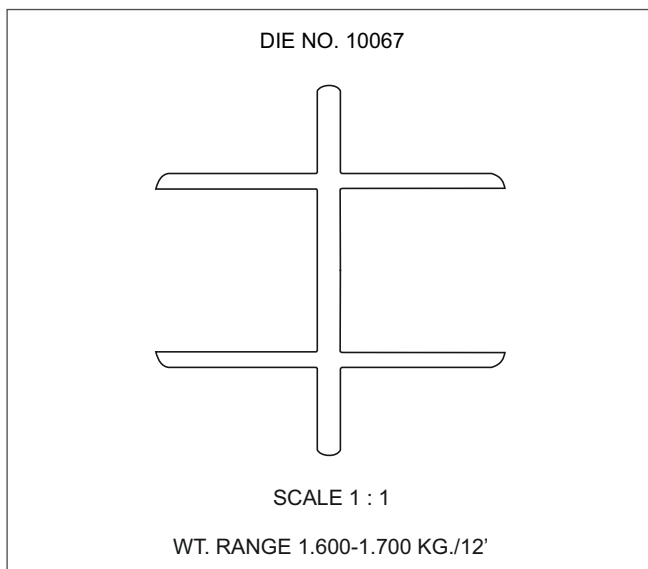
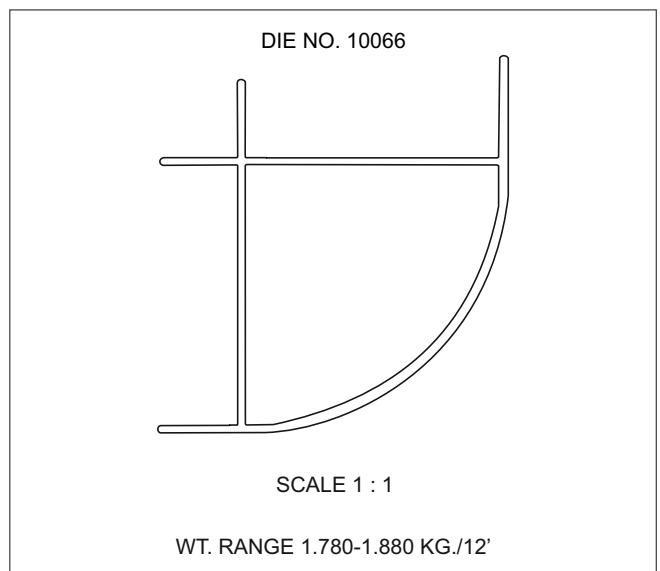
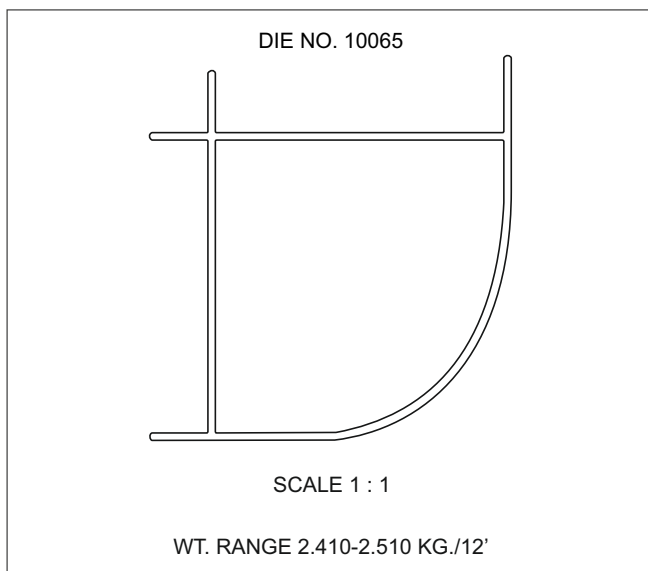
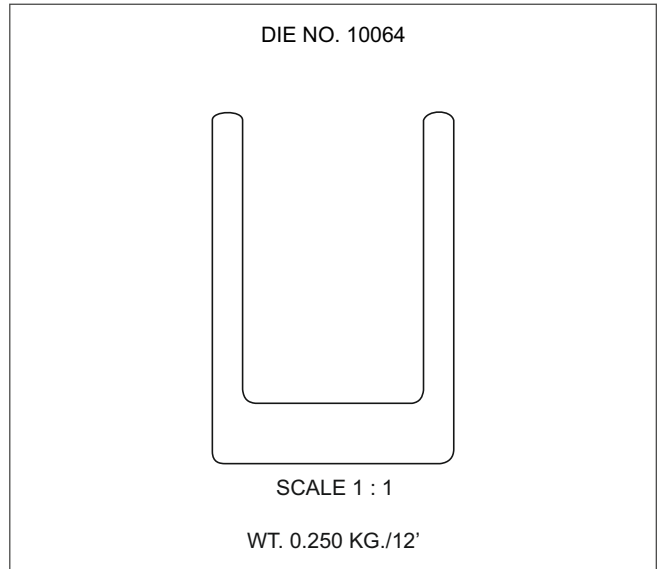

SELECTIONS NOT TO BE SCALED

ALL DIMENSIONS ARE IN MM

**ARCHITECTURAL**

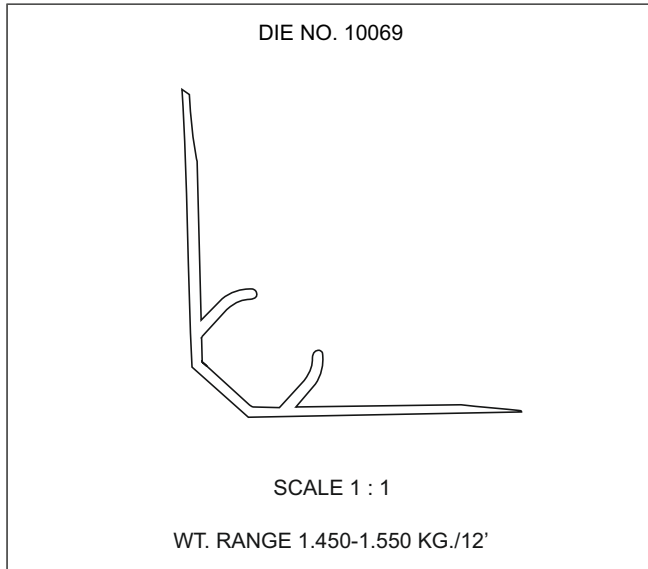

**CLEAN ROOM & OMEGA SECTION**

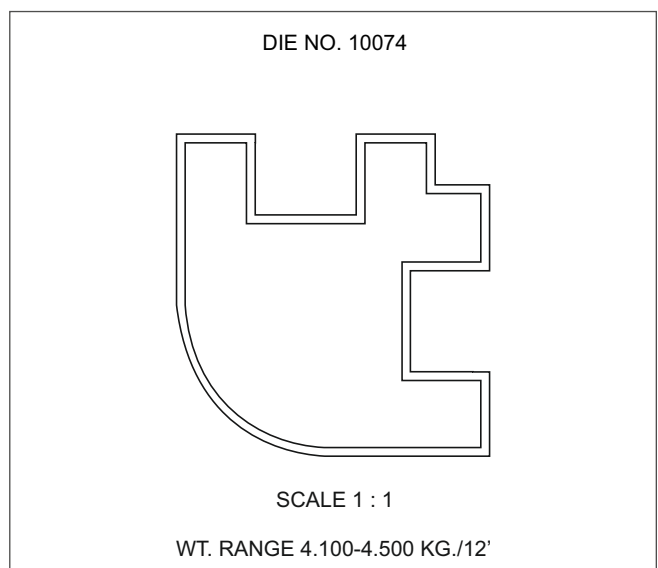
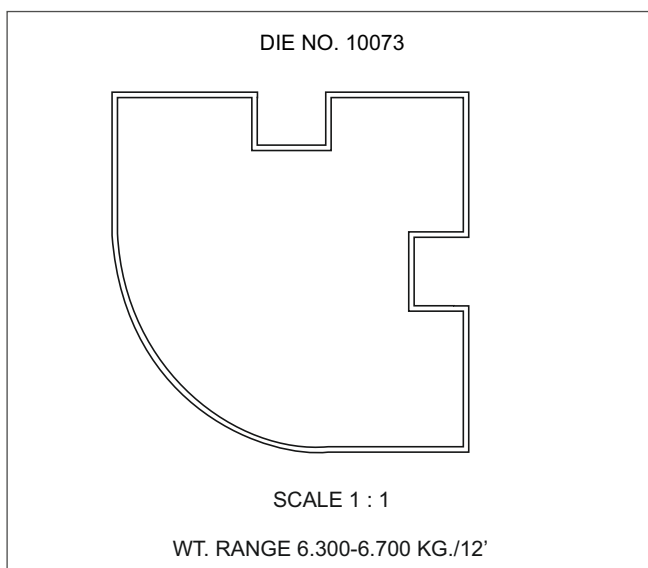
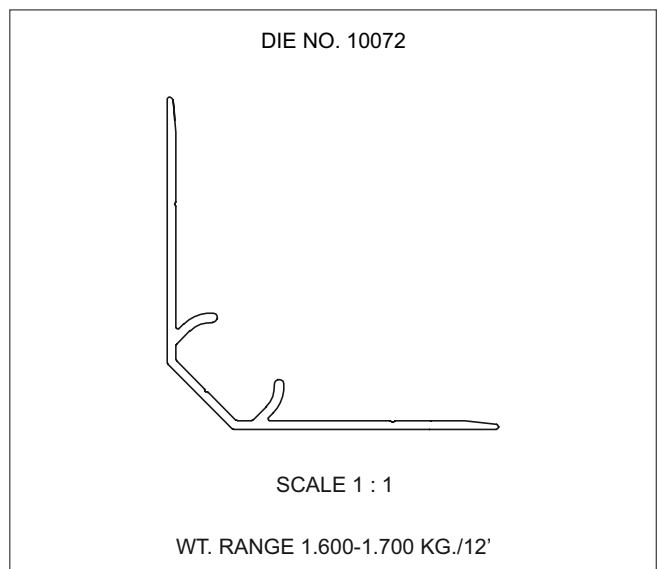
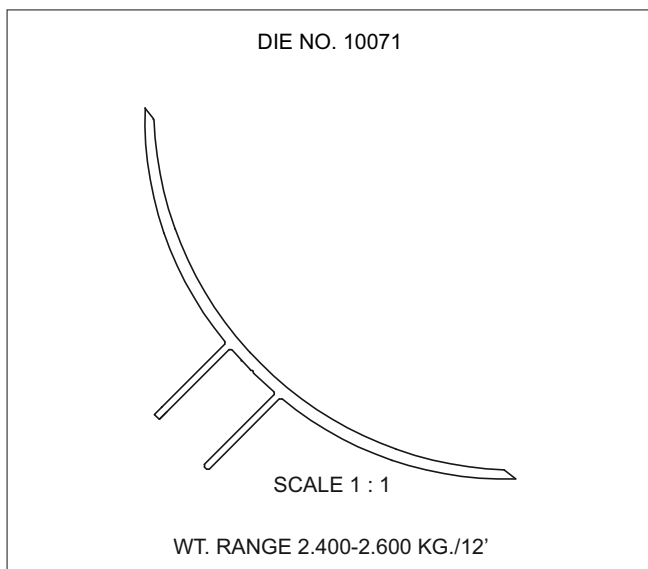
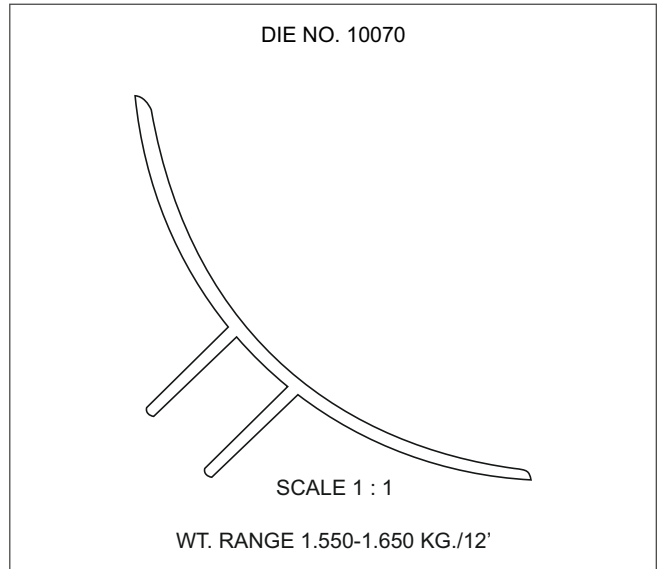

SELECTIONS NOT TO BE SCALED

ALL DIMENSIONS ARE IN MM

**ARCHITECTURAL**

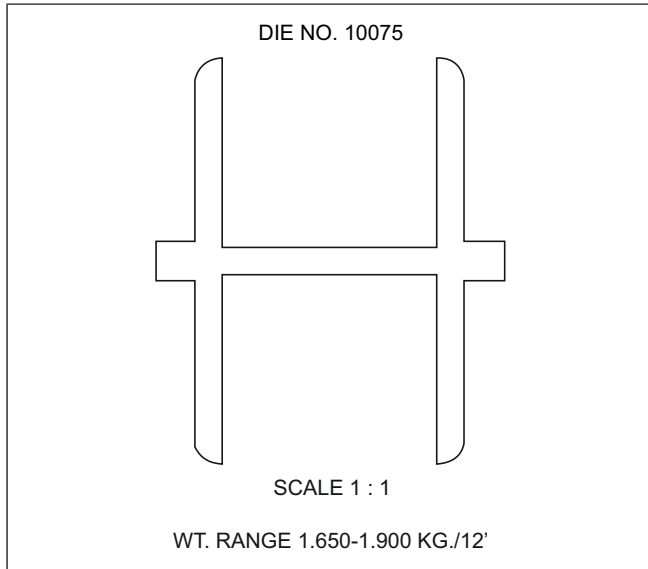

**CLEAN ROOM & OMEGA SECTION**

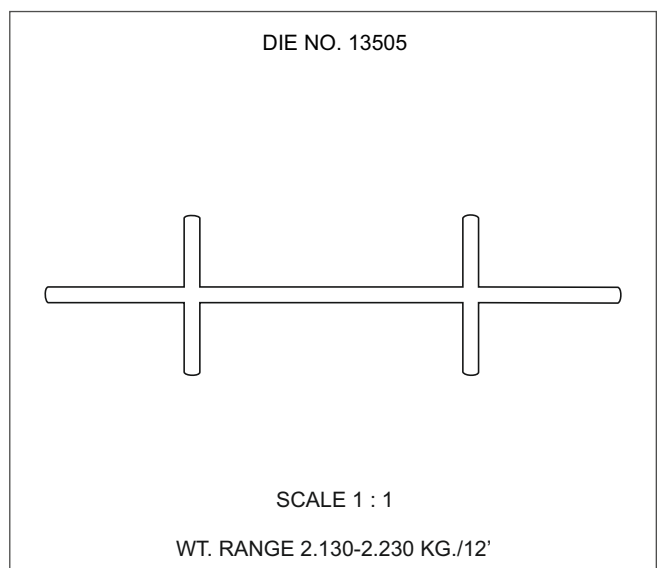
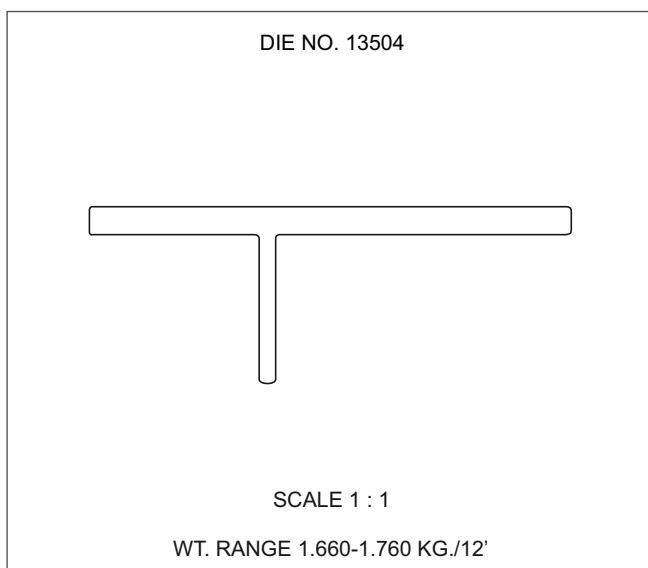
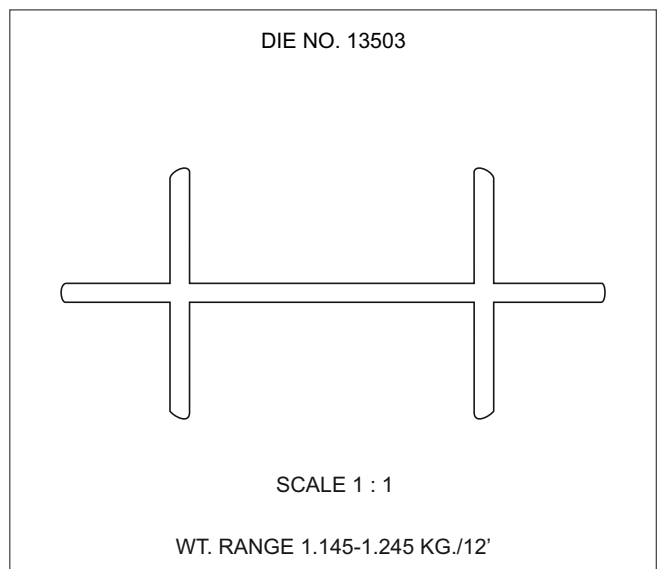
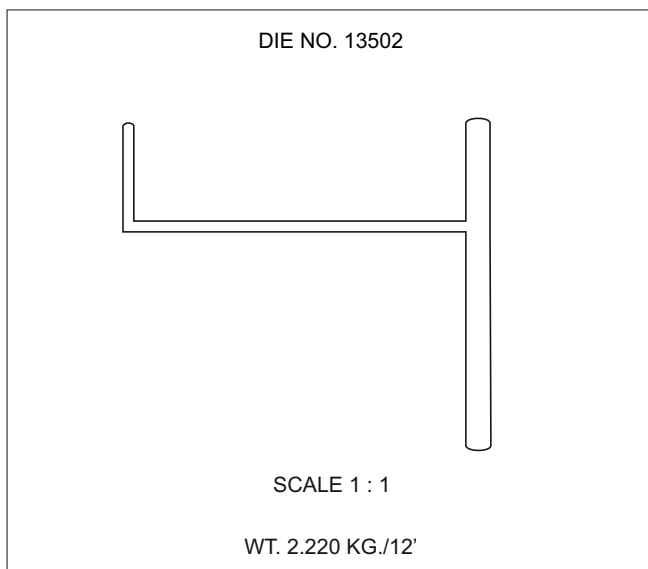
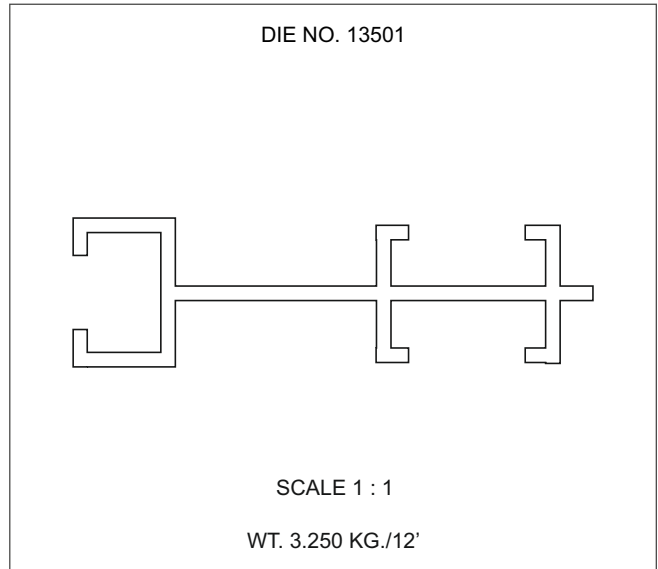

SELECTIONS NOT TO BE SCALED

ALL DIMENSIONS ARE IN MM

**ARCHITECTURAL**

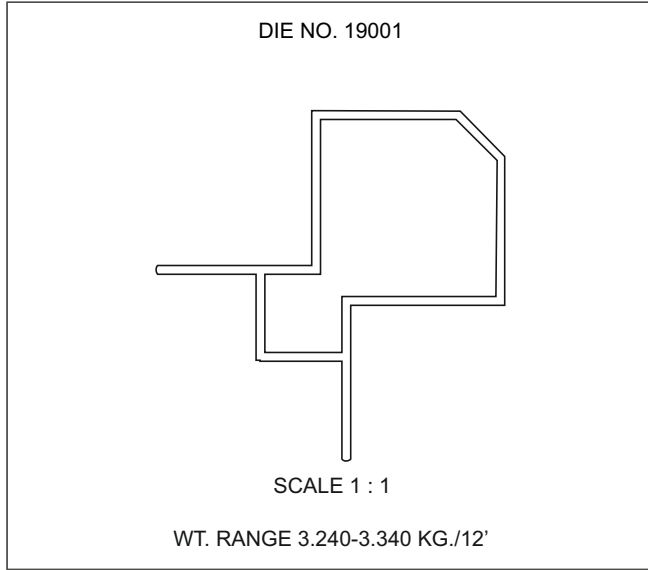

**CLEAN ROOM & OMEGA SECTION**

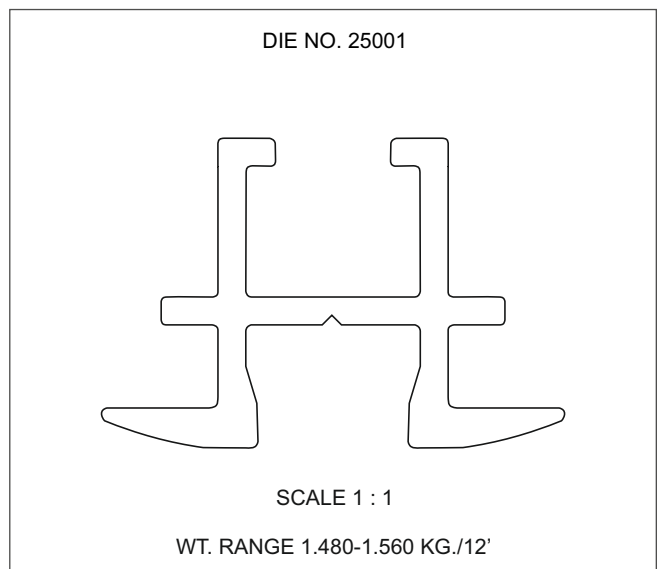
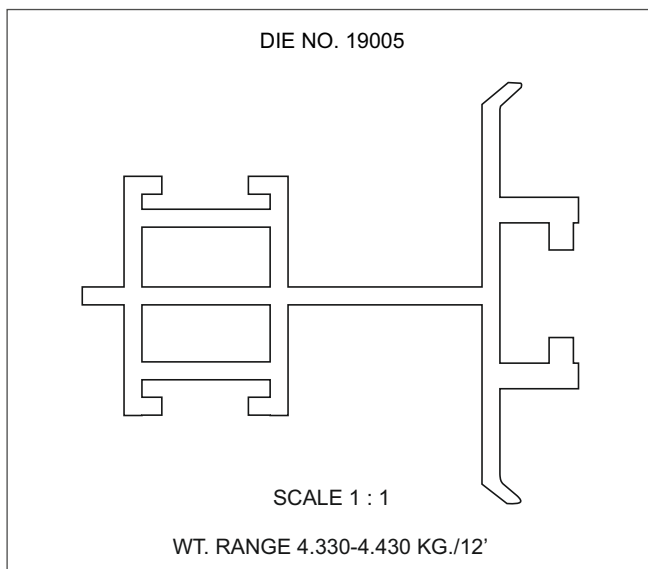
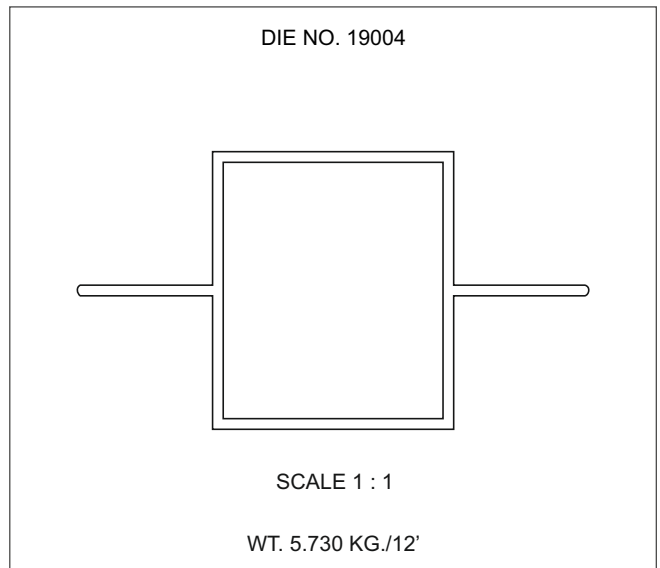
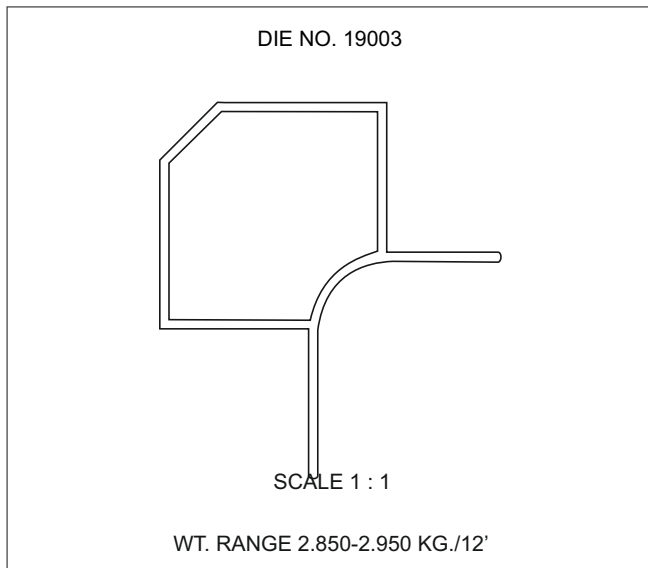
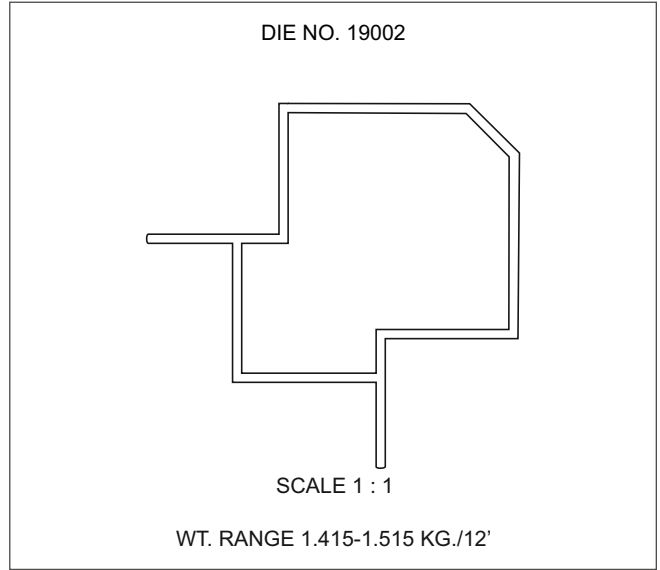

SELECTIONS NOT TO BE SCALED

ALL DIMENSIONS ARE IN MM

**ARCHITECTURAL**

DIE NO. 26001

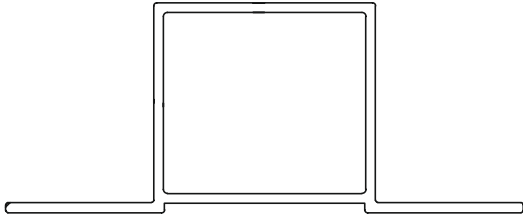

SCALE 1 : 1

WT. 0.545 KG./MTR.

**CLEAN ROOM & OMEGA SECTION**

DIE NO. 26002

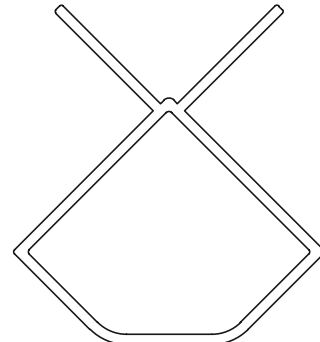

SCALE 1 : 1

WT. 0.545 KG./MTR.

DIE NO. 26003

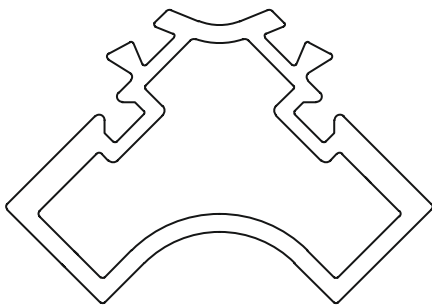

SCALE 1 : 1

WT. 0.790 KG./MTR.

DIE NO. 26004

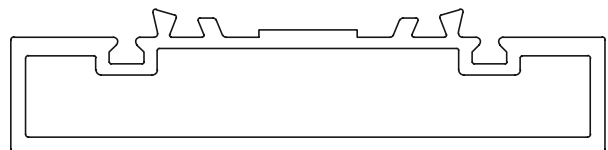

SCALE 1 : 1

WT. 1.140 KG./MTR.

DIE NO. 26005

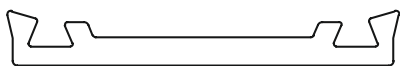

SCALE 1 : 1

WT. 0.357 KG./MTR.

DIE NO. 26006

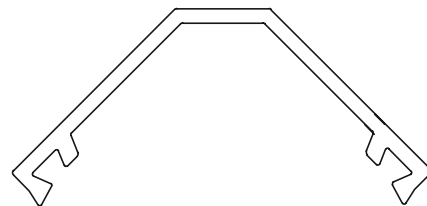

SCALE 1 : 1

WT. 0.455 KG./MTR.'

SELECTIONS NOT TO BE SCALED

ALL DIMENSIONS ARE IN MM

**ARCHITECTURAL**

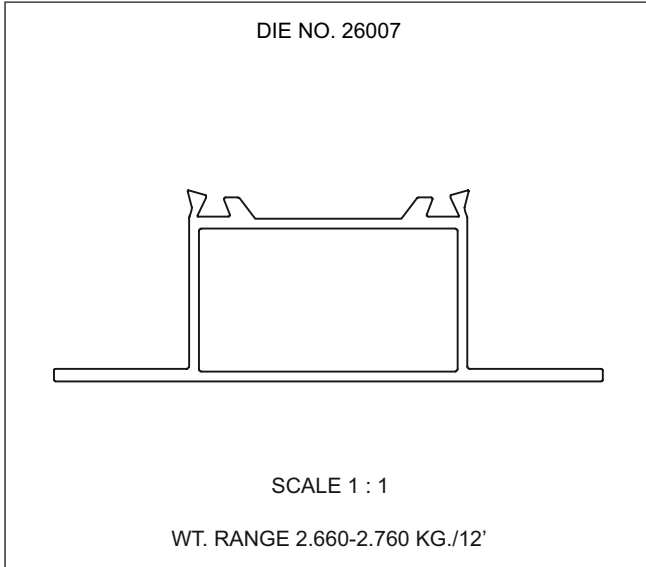

**CLEAN ROOM & OMEGA SECTION**

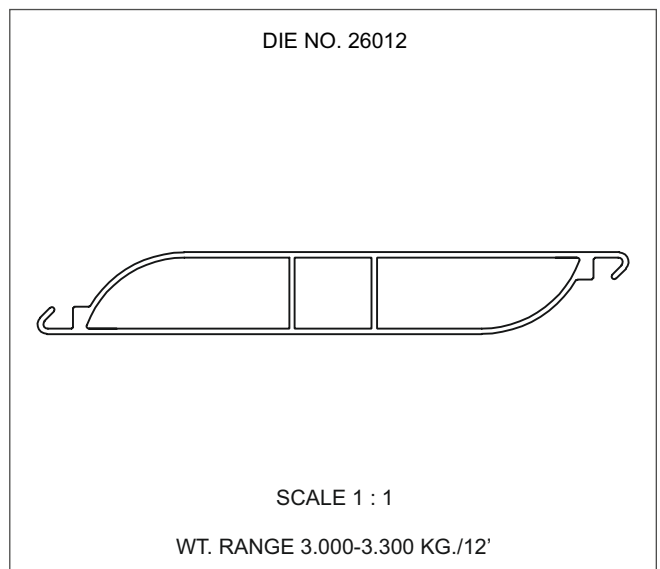
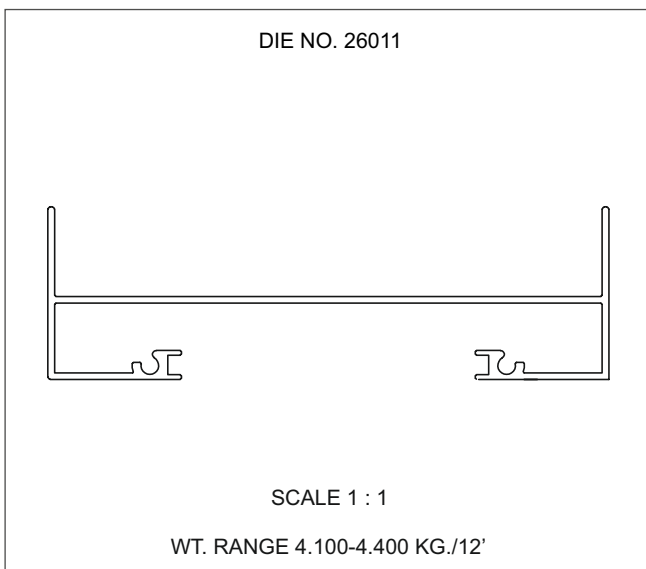
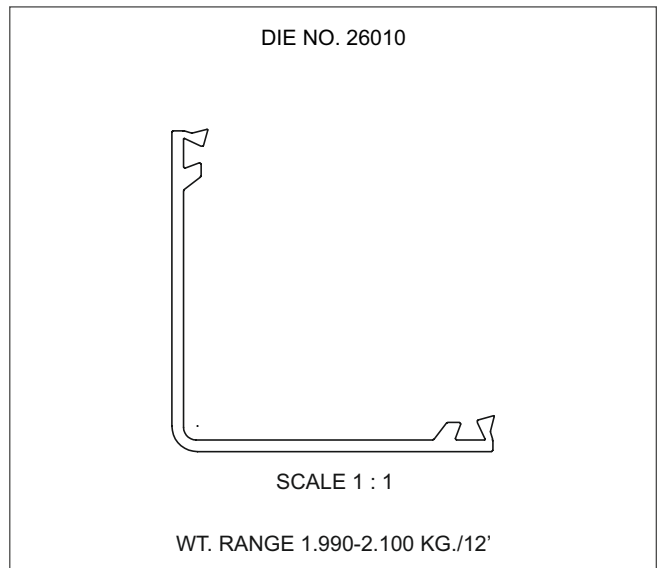
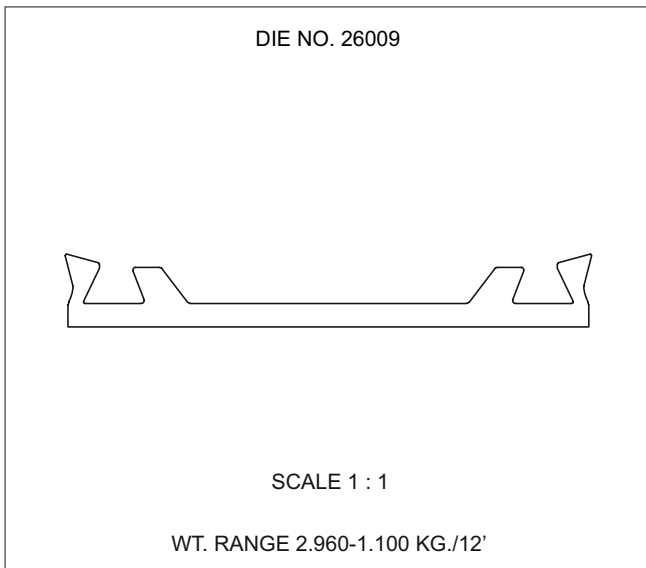
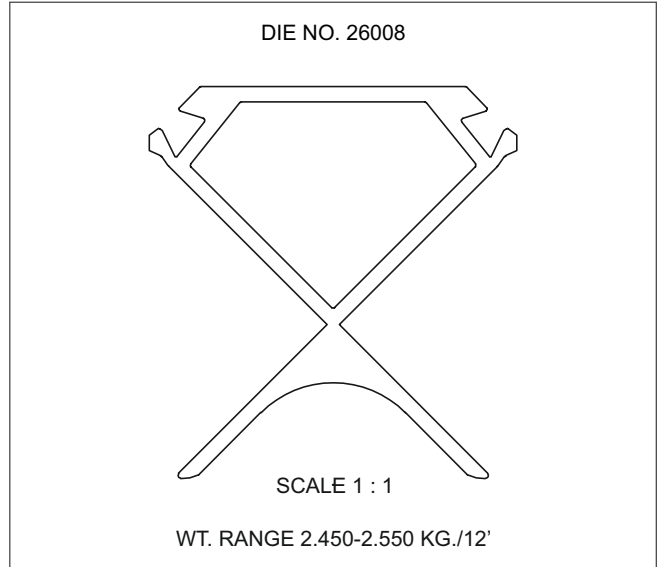

SELECTIONS NOT TO BE SCALED

ALL DIMENSIONS ARE IN MM



**ARCHITECTURAL**

DIE NO. 26013

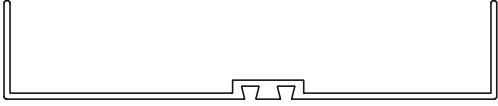

SCALE 1 : 1

WT. RANGE 2.900-3.200 KG./12'

**CLEAN ROOM & OMEGA SECTION**

DIE NO. 30001

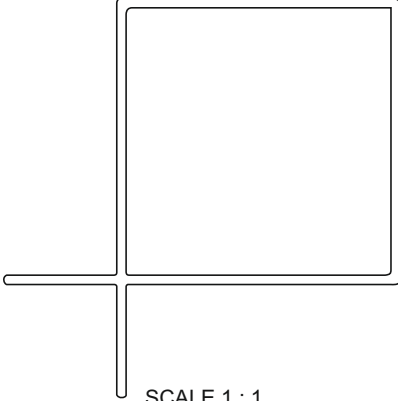

SCALE 1 : 1

WT. RANGE 3.900-4.500 KG./12'

DIE NO. 30002

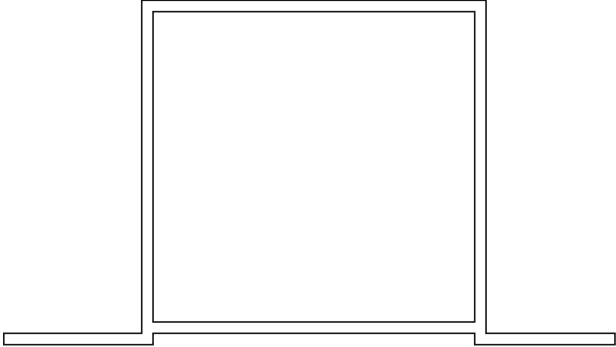

SCALE 1 : 1

WT. 3.900-4.500 KG./12'

DIE NO. 30003

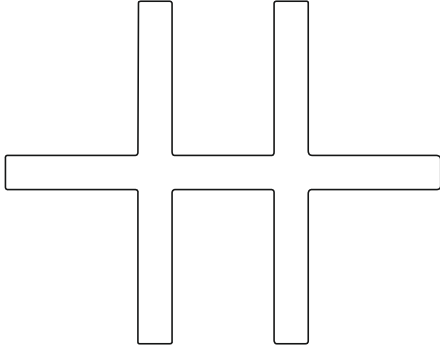

SCALE 1 : 1

WT. RANGE 1.200-1.500 KG./12'

DIE NO. 30004

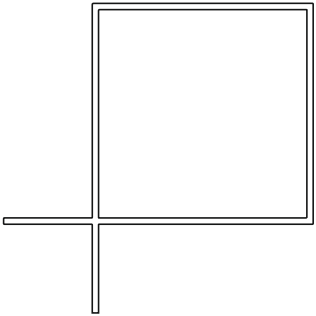

SCALE 1 : 1

WT. RANGE 3.900-4.500 KG./12'

DIE NO. 30005

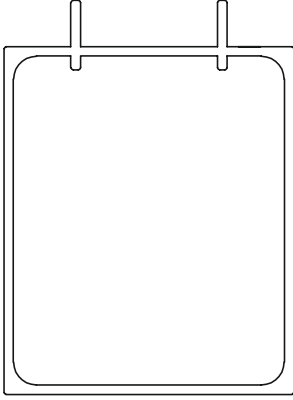

SCALE 1 : 1

WT. RANGE 3.800-4.200 KG./12'

SELECTIONS NOT TO BE SCALED

ALL DIMENSIONS ARE IN MM

**ARCHITECTURAL**

DIE NO. 30006

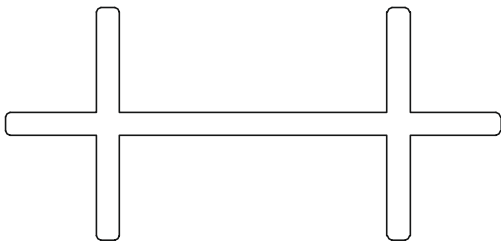

SCALE 1 : 1

WT. RANGE 1.550-1.800 KG./12'

**CLEAN ROOM & OMEGA SECTION**

DIE NO. 30007

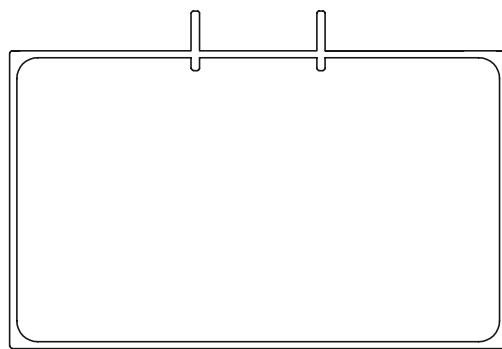

SCALE 1 : 1

WT. RANGE 4.770-5.300 KG./12'

DIE NO. 36501

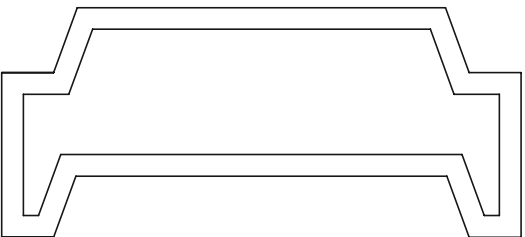

SCALE 1 : 1

WT. RANGE 16.600-17.600 KG./12'

DIE NO. 36502

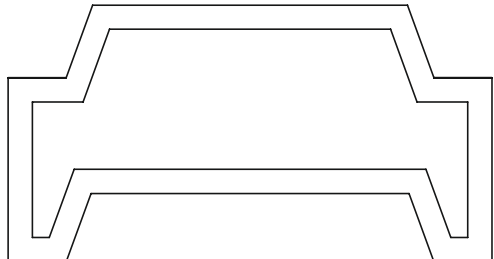

SCALE 1 : 1

WT. RANGE 14.700-15.700 KG./12'

DIE NO. 36503

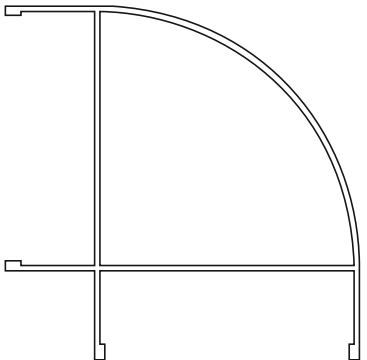

SCALE 1 : 1

WT. RANGE 3.240-3.700 KG./12'

DIE NO. 36504

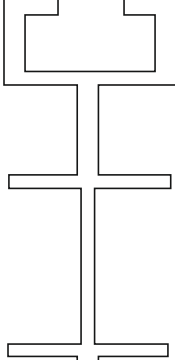

SCALE 1 : 1

WT. RANGE 3.390-3.800 KG./12'

SELECTIONS NOT TO BE SCALED

ALL DIMENSIONS ARE IN MM

**ARCHITECTURAL**

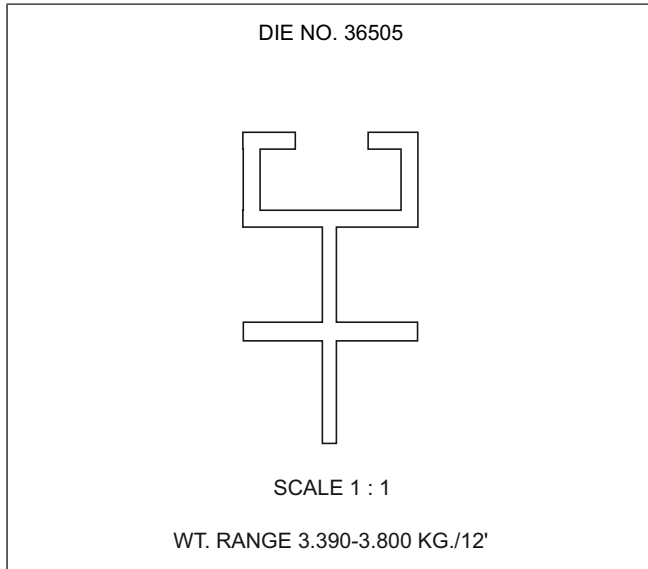

**CLEAN ROOM & OMEGA SECTION**

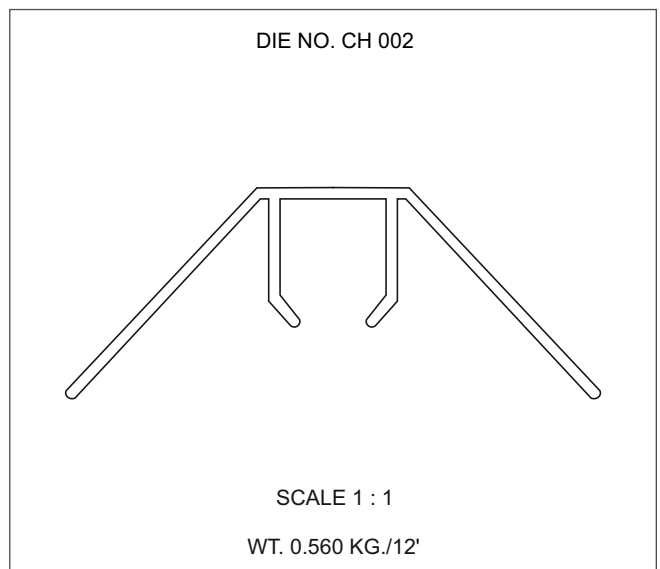
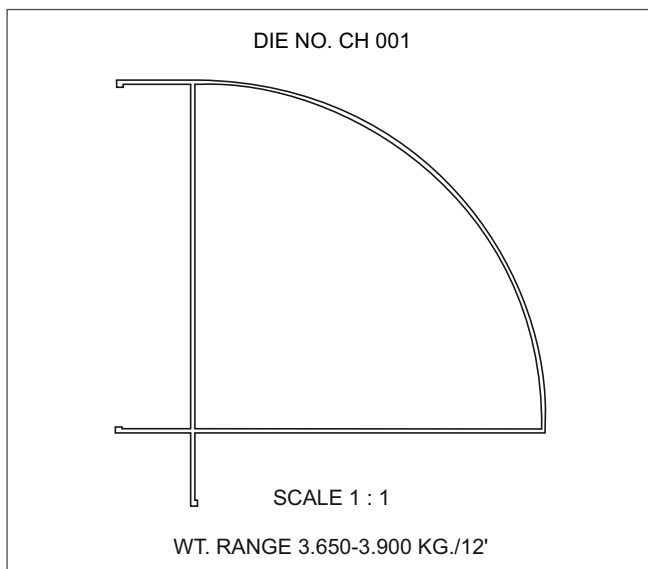
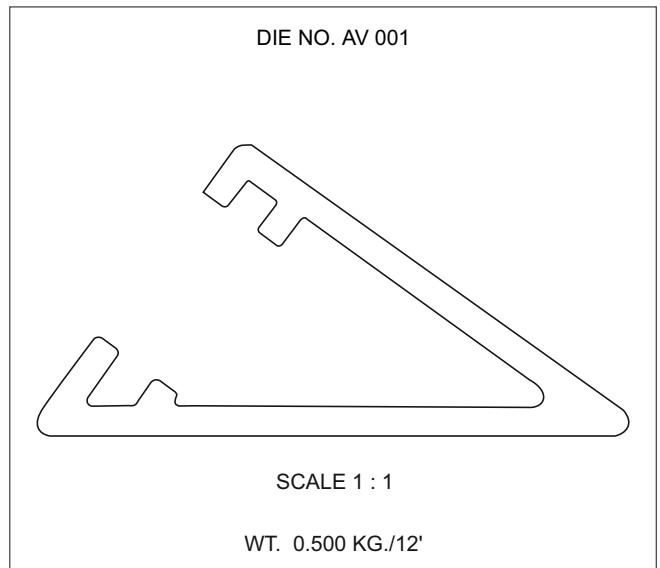
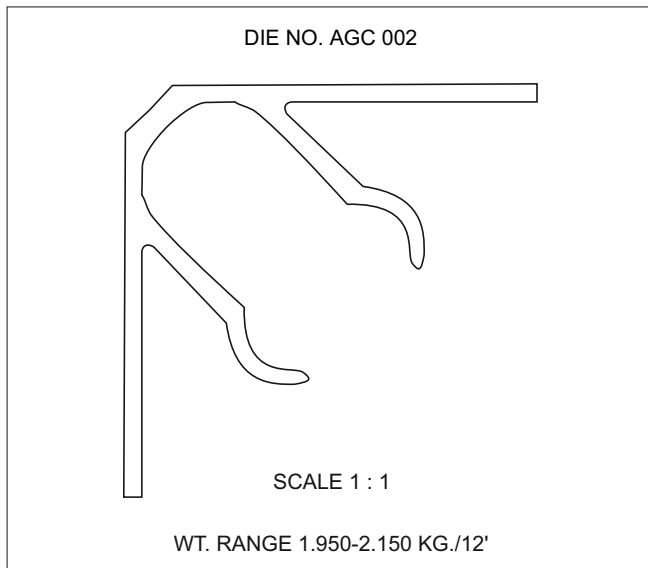
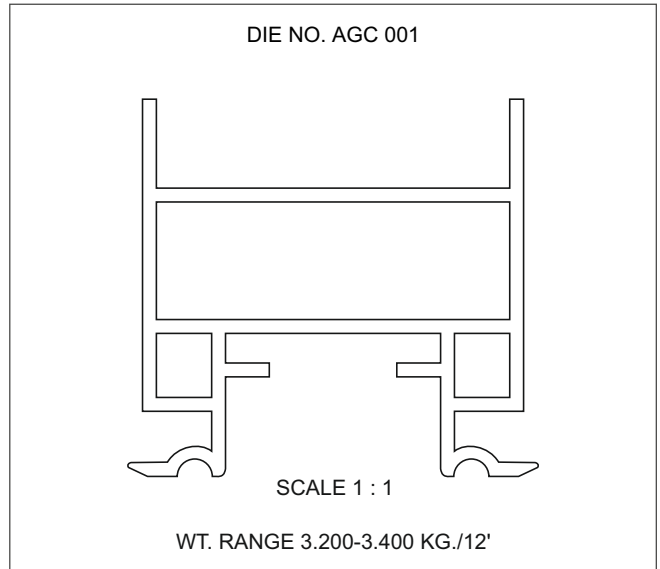

SELECTIONS NOT TO BE SCALED

ALL DIMENSIONS ARE IN MM

**ARCHITECTURAL**

DIE NO. CH 003

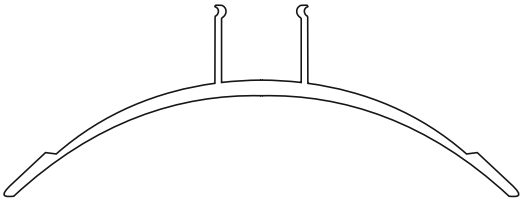

SCALE 1 : 1  
WT. 1.400 KG./12'

**CLEAN ROOM & OMEGA SECTION**

DIE NO. CH 004

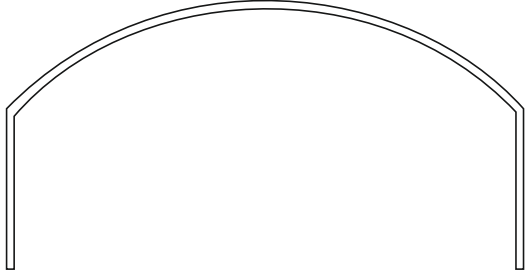

SCALE 1 : 1  
WT. RANGE 1.150-1.330 KG./12'

DIE NO. 36501

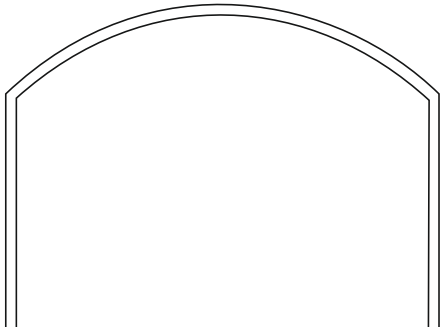

SCALE 1 : 1  
WT. RANGE 0.800-0.900 KG./12'

DIE NO.

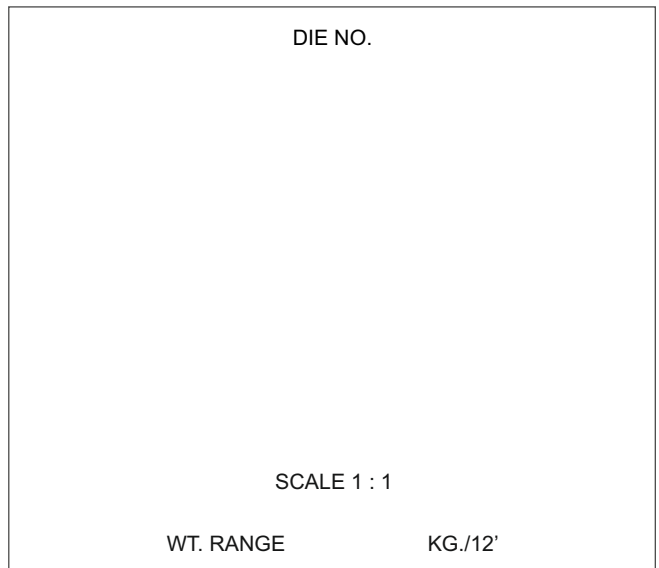

SCALE 1 : 1  
WT. RANGE                      KG./12'

DIE NO.

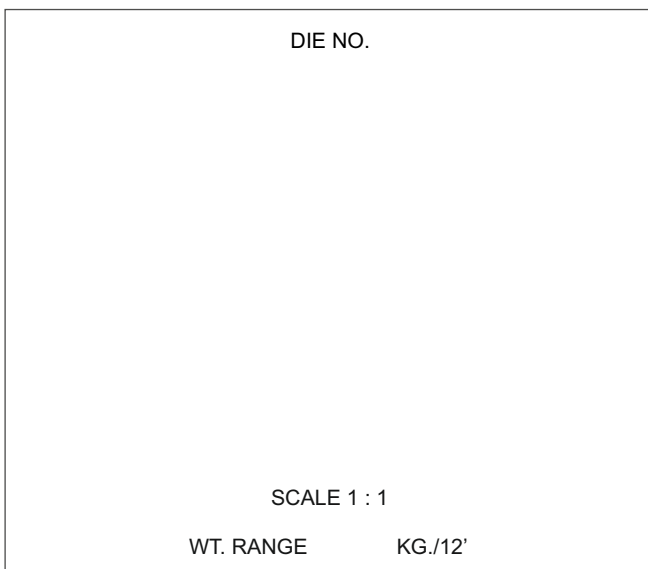

SCALE 1 : 1  
WT. RANGE                      KG./12'

DIE NO.

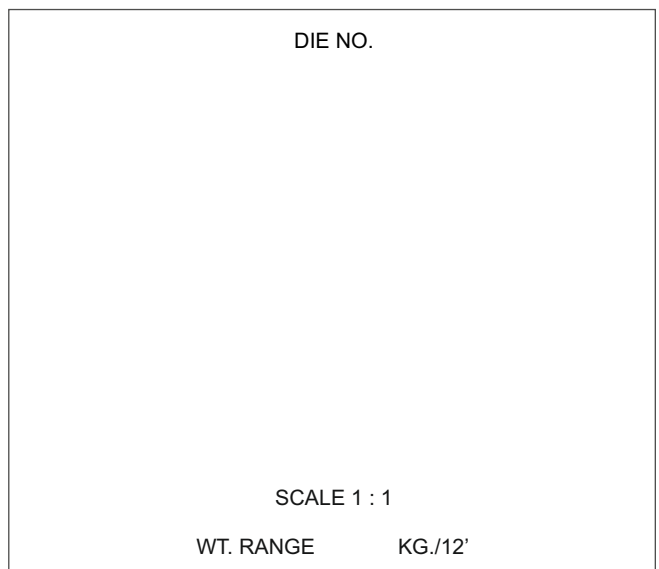

SCALE 1 : 1  
WT. RANGE                      KG./12'

SELECTIONS NOT TO BE SCALED

ALL DIMENSIONS ARE IN MM