



PILOT OPERATED PRESSURE RELIEF VALVES PPR

ENGINEERING

1

Ref. No. P04897

Release 07/2008

Description

Two stage poppet type Relief Valve.
Solenoid Unloading facility as an Optional feature.
Vent Connection for remote control.
Three Standard sizes in Sub-plate mounting construction.
Five standard sizes in Threaded Construction.



Section

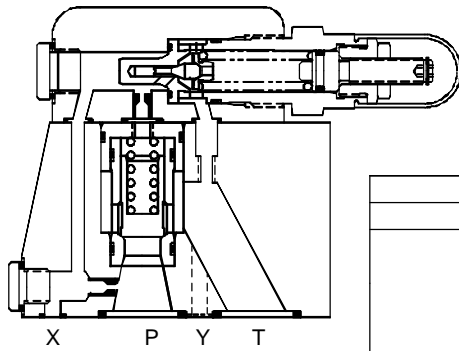

Hydraulic Symbol

PPR Description	Normally	
	Open	Close
Internal pilot Internal Drain		
X - External pilot Internal Drain		
Internal pilot Y - External Drain		
X - External pilot Y - External Drain		

Polyhydron Pvt. Ltd.

78-80, Machhe Industrial Estate,
Machhe, Belgaum - 590 014. INDIA.

Phone : +91-(0)831-411001
Fax : +91-(0)831-411002
E-mail : polyhydron@vsnl.com
Website : www.polyhydron.com



PILOT OPERATED PRESSURE RELIEF VALVES PPR

ENGINEERING

2

Ref. No. P04897

Unit Dimensions

Valve : Subplate mounting.

Size	10	20	30
H1	120	115	143
H2	82	76	93
H3	-	12	14
L1	150	167	182
L2	80	120	155
L3	0	5	5
L4	13.1	35.9	47.3
L5	53.8	66.7	88.9
M	M12	M16	M18
W1	80	100	120
W2	53.8	70	82.6
Mass kg.	4.8	6.7	12

Table No. 2

Size	Valve fixing screws S.H.C. Screw	Tighting torque
10	M12 x 100 L, 4 M16 x 90 L, 4 nos.	120 Nm.
20	M16 x 100 L, 4 nos.	295 Nm.

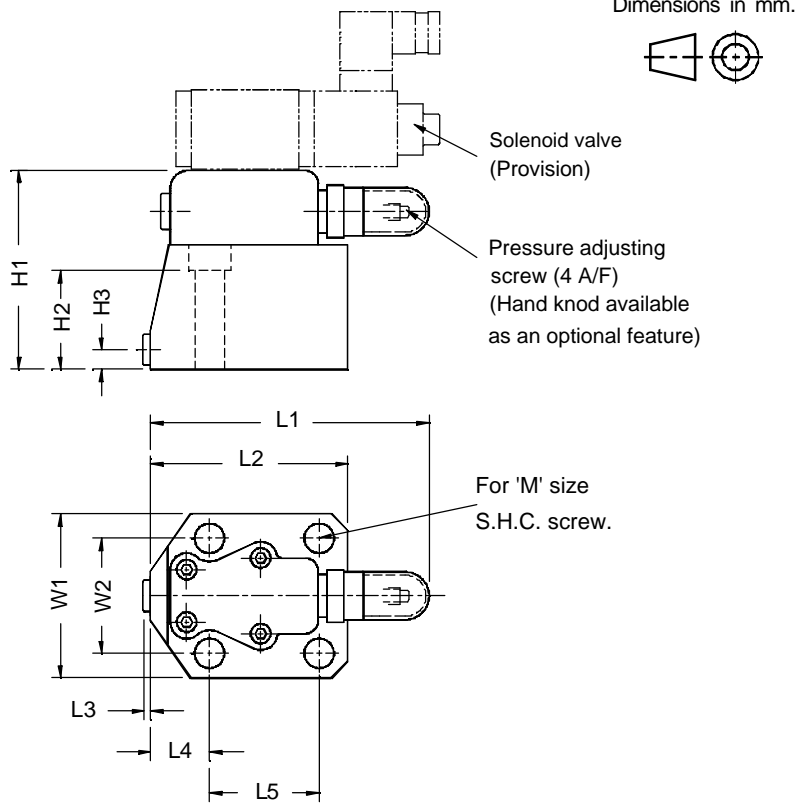

Valve : Threaded body

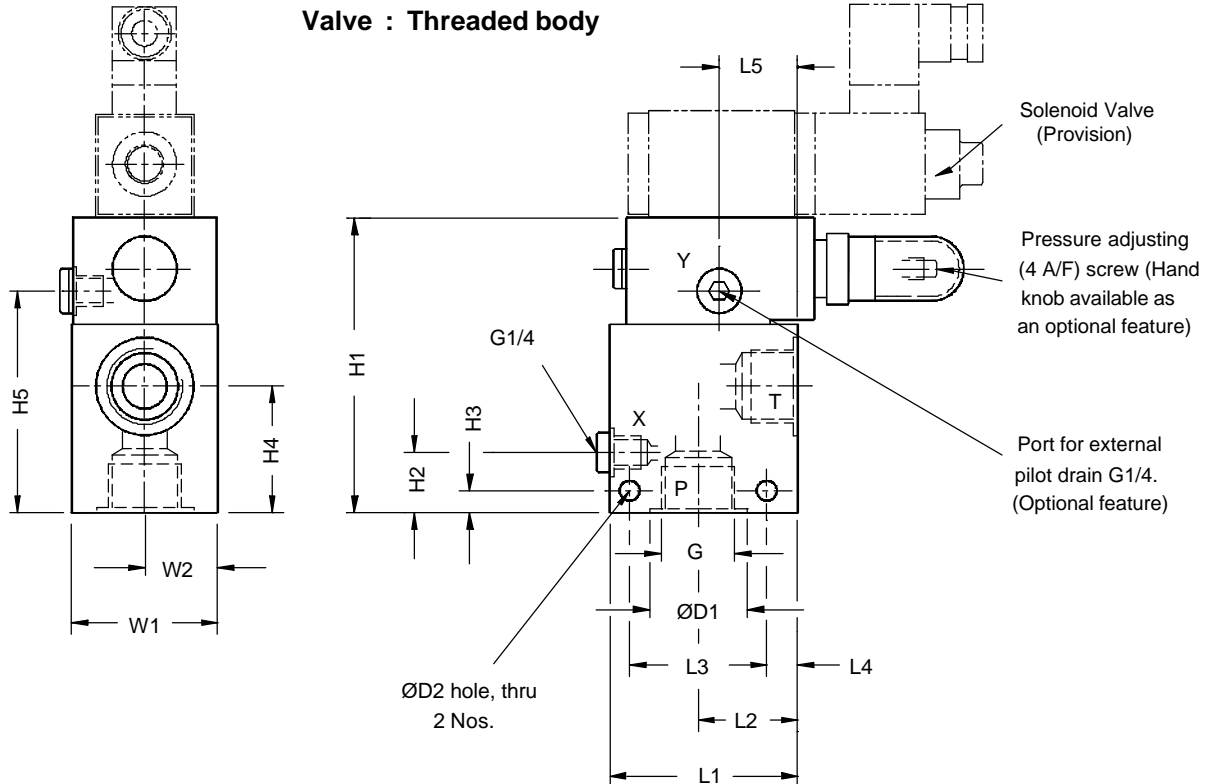

Size	Mass Kg.	G	H1	H2	H3	H4	H5	L1	L2	L3	L4	L5	W1	W2	ØD1	ØD2
20	4.8	G1	133	27	10	57	100	85	45	62	14	35.5	66	33	44	9
30	9.5	G1 1/2	170	42	13	80	138	100	54	72	18	41.5	86	43	60	11

Accessory : Subplate

Table No. 4

Size	Model	B1	B2	B3	B4	B5	B6	B7	B8	B9	ØD1	ØD2	ØD3	ØD4	ØD5	ØD6	G	L1	L2	L3
10	1SR06G04	10	65	85	5.6	26.9	53.8	32.5	30.5	56.5	14	30	9	14.5	4.5	4.5	G1/2	10	30.	0
20	1SR08G06	12	81	105	5.5	35	70	40.5	40.5	72.5	18	36	14	20	6.3	6.3	G3/4	12	48.	23.8
	22.5										44	G1								
30	1SR10G10	12	101	125	9.2	41.3	82.6	50.5	50.5	92	25	54	14	20	6.3	6.3	G1 1/4	12	55.	31.8
	31.7										60	G1 1/2								

Size	Model	L4	L5	L6	L7	L8	L9	L10	L11	L12	L13	L14	L15	L16	M	R1	R2	T1	T2	W
10	1SR06G04	22.1	22.1	47.5	53.8	10	45	85	85	60	110	130	31.8	65	M12	31	16	22	22	35
20	1SR08G06	11.1	33.4	55.6	66.7	8	52	112	124	102	146	170	43.7	84.5	M16	30	16	13	26	40
	1SR08G08																			
30	1SR10G10	12.7	44.5	76.2	88.9	13	63	138	139	90	176	200	54.9	105	M18	40	16	15	30	42
	1SR10G12																			

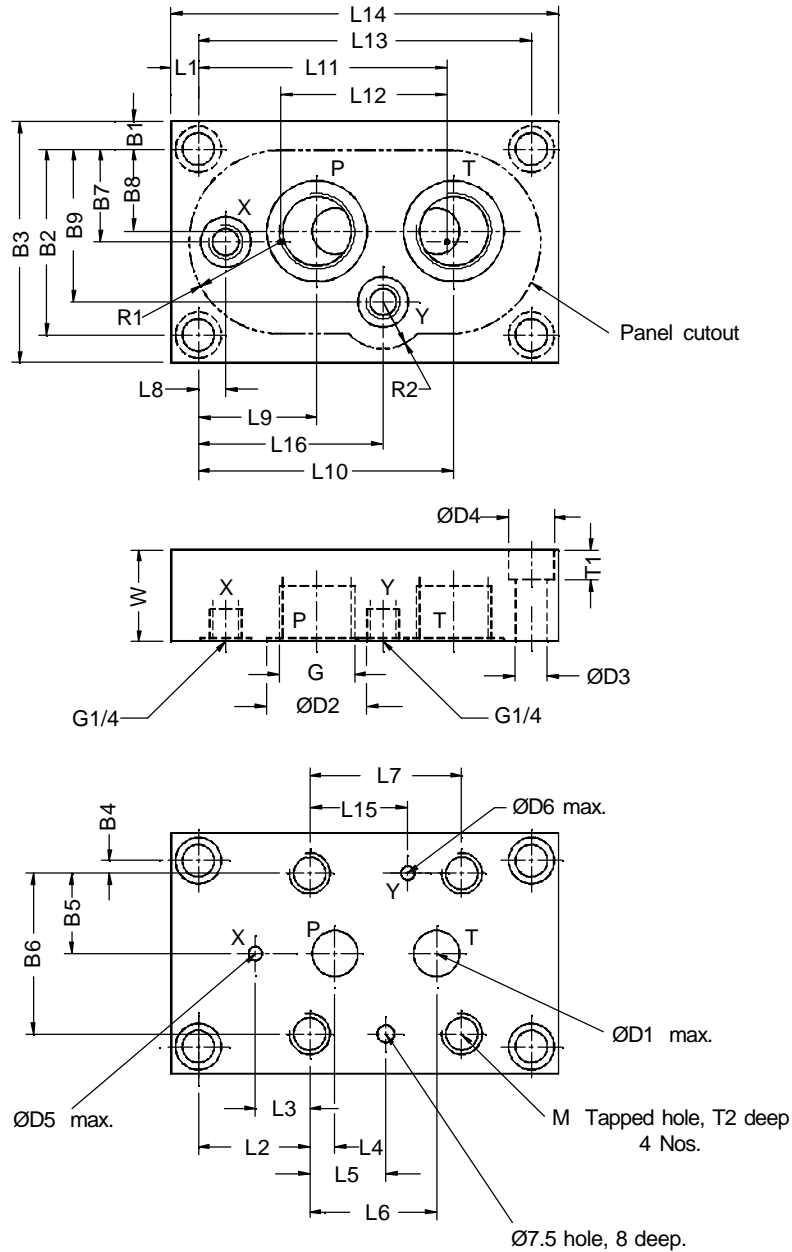

PILOT OPERATED PRESSURE RELIEF VALVES PPR

ENGINEERING

4

Ref. No. P04897

Technical Specifications

Construction	Two stage poppet valve.
Mounting	Threaded bodies; company standards Sub-Plate Mounting; ISO6264.
Mounting position	Optional.
Flow direction	From port 'P' to port 'T'.
Operating pressure	
For valves with internal drain	For port P and X 315 bar For port T 60 bar
For valves with external drain	For port P and X 315 bar For port T 315 bar For port Y 60 bar
Hydraulic medium	Mineral oil.
Viscosity range	10 cSt to 380 cSt.
Fluid temperature range	-20 °C to +70 °C.
Fluid cleanliness requirement	As per ISO 16/13.
Maximum flow handling capacity	For valve size
	10 100 l/min.
	20 200 l/min.
	30 400 l/min.
Mass	Refer individual table.

Ordering Code

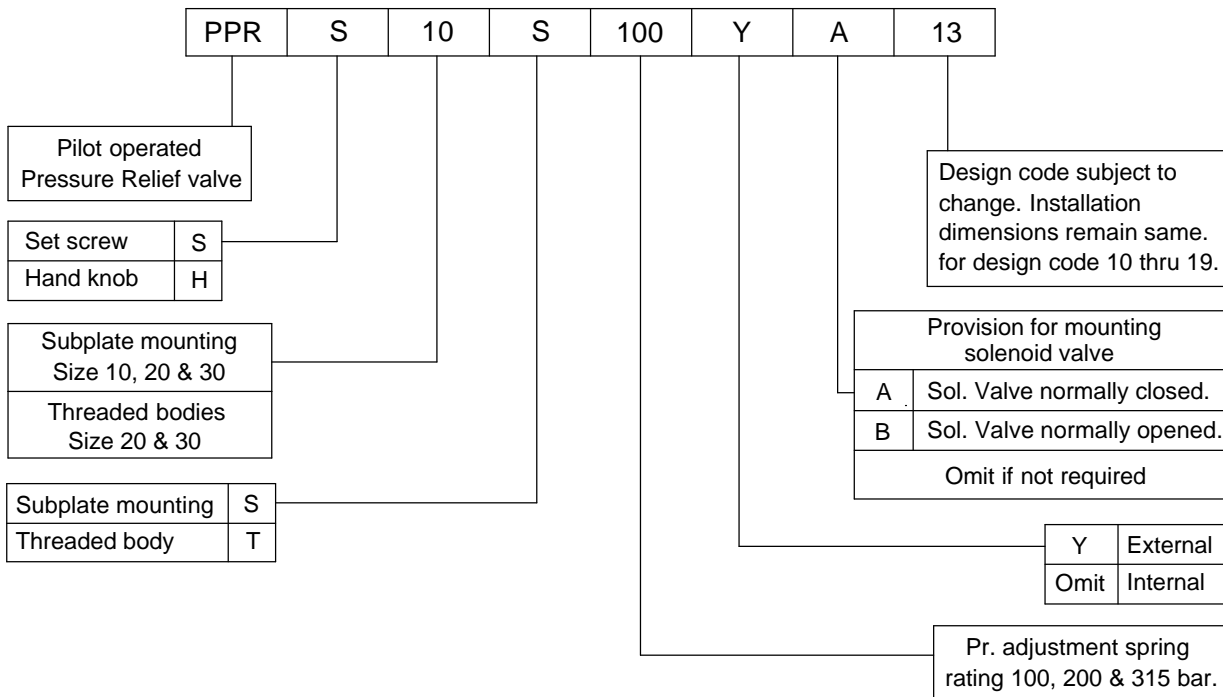

Note : Solenoid (refer spool type) and Subplate to be ordered separately.

