



LEVEL GAUGE

Features & Description

- 'O' Ring type construction
- 2 size 3" & 5" between bolt centre
- For non pressurised tanks only
- Can mounted on tapped holes
- Suitable for mineral & petroleum based oils
- Maximum temperature 80°C



Unit Dimensions

Face type

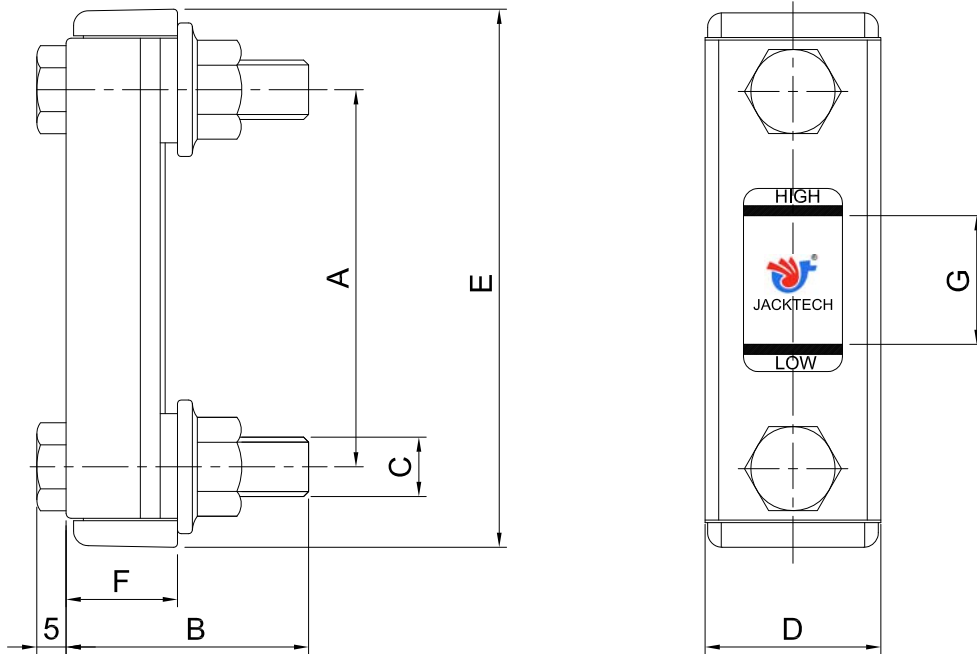

Table-1

MODEL CODE	A	B	C	D	E	F	G
FLG 6 - 03	3"	48	M12	34	108	20	37
FLG 6 - 05	5"	48	M12	34	159	20	76



LEVEL GAUGE

Assembly details

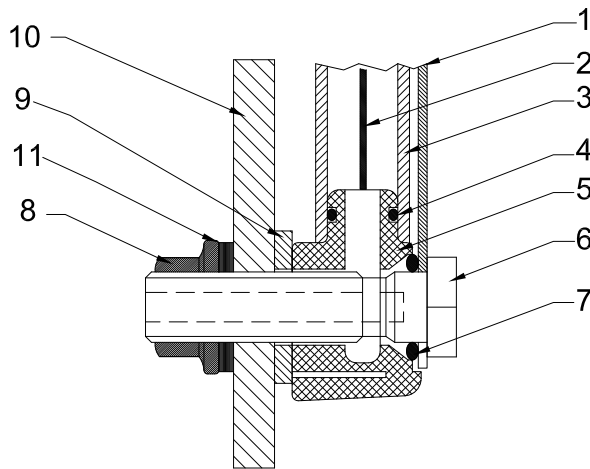

1. COVER
2. INDICATOR
3. TUBE
4. 'O' RING
5. END PIECE
6. BOLT M12
7. 'O' RING
8. NUT
9. WASHER (RUBBER)
10. TANK PLATE
11. MS WASHER

Note: * Bolt Torque to be limited to 3 FT LBS

Unit Dimensions

Knob (Threaded) type (Sight level gauge)

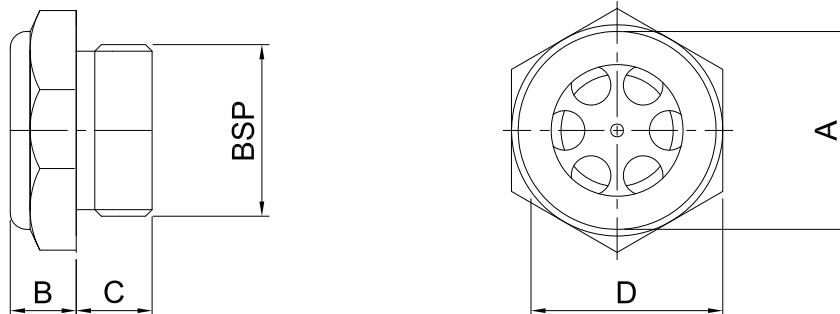

Table-2

Part no.	BSP	A	B	C	D
KLG - 1/4"	1/4"	10	8	8	17
KLG - 3/8"	3/8"	12	7	9	22
KLG - 1/2"	1/2"	15	7	10	27
KLG - 3/4"	3/4"	20	8	11	32
KLG - 1"	1"	25	9	14	40
KLG - 1 1/4"	1 1/4"	34	9	15	50
KLG - 1 1/2"	1 1/2"	38	9	15	55