

GENERAL SPECIFICATIONS

- Input supply** : Input supply 220v to 250v A/C, 50Hz
- Channel(Output)** : 10 Channel (230v A/C Output)
- On Time** : Pulse Duration Range of Adjustability 20 to 200 Mili Seconds /Multiple of 20 Sec
- Off Time** : Pulse Frequency Range Of Adjustability 2 to 180 Seconds /Multiple of 18 Sec
- Number of Sequence steps** : 2 to through 10, adjustable in field (Factory set at 10)
- Protection** : Main's Incoming Fuse 3 Amps. Quick Blow Ceramic
- Temperature** : Operating Temperature Range 0 C to 50C,
- Accuracy** : Repetitive Accuracy On Time sequence +/- 5 %
- Current Rating** : Current rating per sequence step, max . in rush current 2A at 230v A/C (50Hz)
- Mountings** : Four holes of 5.5mm each at four corners (steel enclosure on request)
- Dimensions** : Open type, 215mm length, 147mm wide ,and 48mm height.
- Indication** : Power on LED provides visual indication and pilot valve number 1 is immediately energized. " Output 1 " LED provides visual indication of this event. The pilot valve will remain energized for the length of time as set by the time setting trim pot.

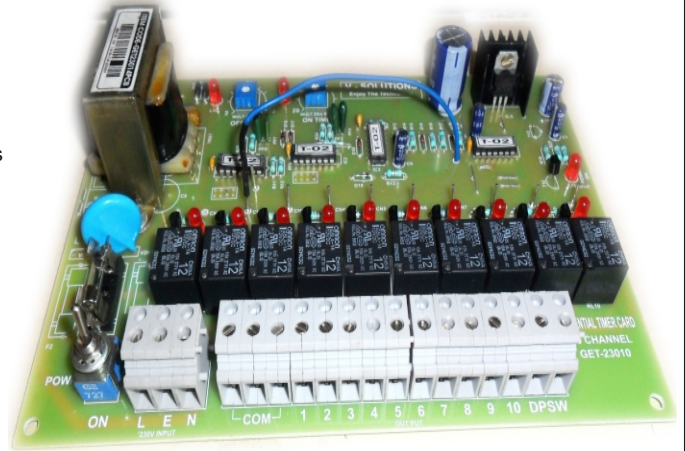

SEQUENTIAL TIMER CARD designed by **v-solutions** is to operate the solenoid pilot valves used on dust collector equipment. LED provide visual indication of energized pilot valve in sequence, and also "power on " indication. The number of sequence step is adjustable from 2 through 10.

Controls are provided to adjust the length of time between valves being energized (pulse frequency) and the length of time that the valve is energized (pulse duration). Silicon semiconductor components control all timing and logic functions.

Two independent methods of starting and stopping the timer are provided.

The first method will automatically stop the sequence and reset the controller to the first valve position whenever A/C power is removed and then reconnected. The second method is by a remote contact connected to the terminals provided.

Field Wiring Procedure

A 18 -POINT terminal block for connection of conductors is provided on the timer for convenient wiring of the control power, loads and remote contact (if used)

Wiring Diagram illustrates, where all necessary wiring should be made. Loads should be wired in desired sequence as needed. Only after all connection has been re-checked, should power be applied to the controller.

Warranty:

one year manufacturers warranty on freight paid basis. All products are manufactured under strict quality control process and utmost care is taken for selection of best components of reputed brands only. Warranty covers components only.

Instructions:

1. When remote contact is used, jumper between half (P1 & P2) must be removed.
2. Number of sequenced steps are adjustable in field by moving jumper wire

Dealer.



Wiring Diagram

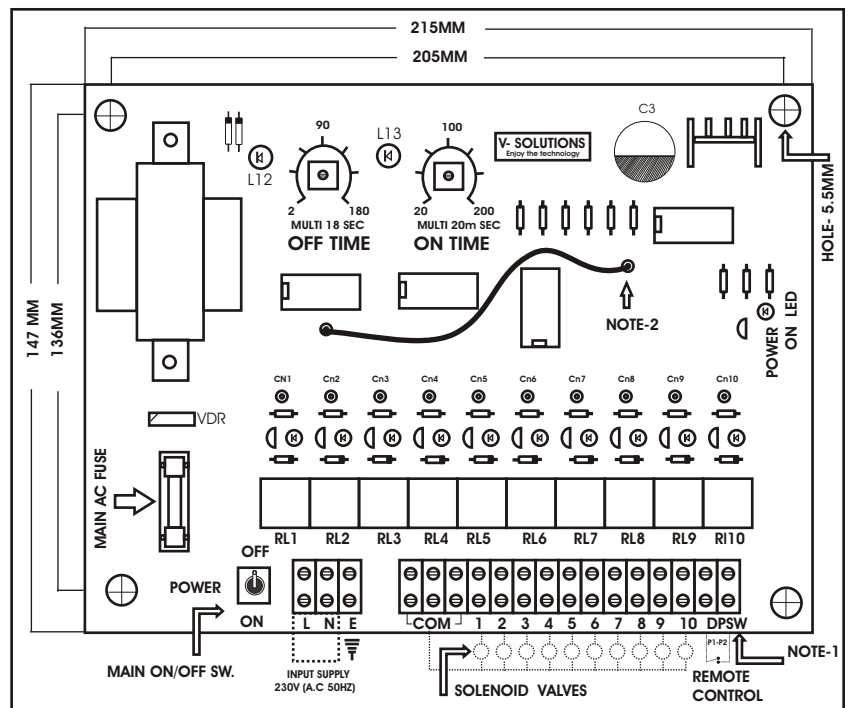

Manufactured by:
GOLDEN ELECTRONICS