



SOURCING    STORING    SUPPLY



## Threaded Studs(Internal Threaded)

**Material: Stainless Steel**



**Stainless Steel**

**Part Code: MV2-4X-WTI**

**Example:**  
MVX- XX- XXX

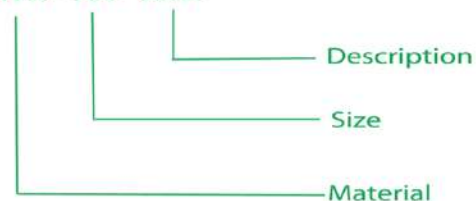

$d_2 * l_1$	$d_1 \pm 0.6$	$b \pm 0.5$	$d_3 \pm 0.2$	$d_4 \pm 0.08$	$l_3$	$h$	$\alpha \pm 1^0$
M4*6	6	6.00	7.50	0.75	0.80	0.7-1.4	3°
M4*8	6	6.00	7.50	0.75	0.80	0.7-1.4	3°
M4*10	6	6.00	7.50	0.75	0.80	0.7-1.4	3°
M4*12	6	6.00	7.50	0.75	0.80	0.7-1.4	3°
M4*15	6	6.00	7.50	0.75	0.80	0.7-1.4	3°
M4*16	6	6.00	7.50	0.75	0.80	0.7-1.4	3°
M4*20	6	6.00	7.50	0.75	0.80	0.7-1.4	3°
M4*25	6	6.00	7.50	0.75	0.80	0.7-1.4	3°
M4*30	6	6.00	7.50	0.75	0.80	0.7-1.4	3°
M4*35	6	6.00	7.50	0.75	0.80	0.7-1.4	3°
M4*40	6	6.00	7.50	0.75	0.80	0.7-1.4	3°
M4*45	6	6.00	7.50	0.75	0.80	0.7-1.4	3°

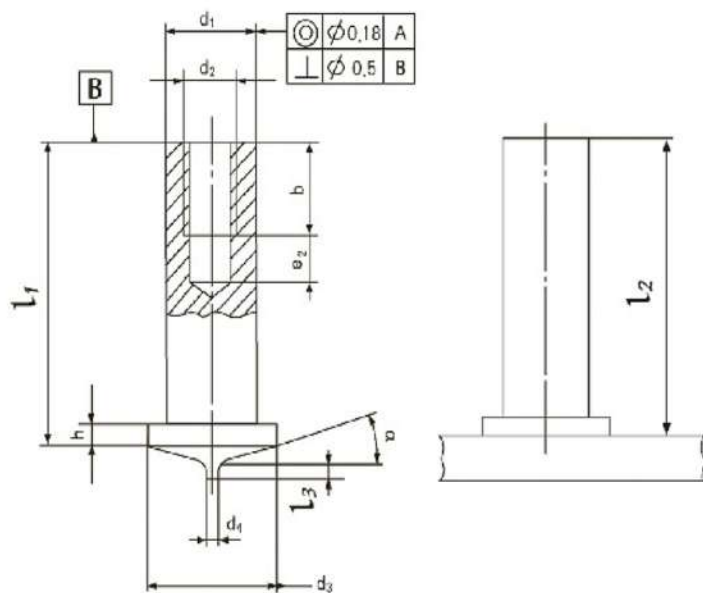

**(Before Welding)**

**(After Welding)**