



SOURCING STORING SUPPLY

Part Code:
MV-KF2 / MV-KFS2



Broaching Nuts

Electro Tin Plated Steel: MV-KF2 | Stainless Steel: MV-KFS2

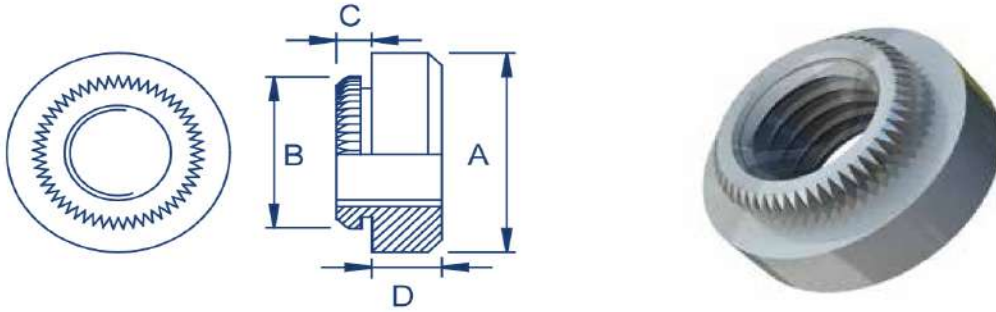

Metric Dimensions

Thread	M2	M2.5	M3	M3.5	M4	M5
C max	1.53	1.53	1.53	1.53	1.53	1.53
B ±0.08	4.19	4.68	4.68	5.88	6.86	7.37
A ±0.13	5.56	5.56	5.56	7	8.74	9.53
D ±0.13	1.5	1.5	1.5	1.6	2	3
Min rec sheet thickness	1.53	1.53	1.53	1.53	1.53	1.53
Hole size +0.08 -0.00	3.73	4.22	4.22	5.5	6.40	6.90
Min distance to edge of sheet	4.2	4.4	4.4	5.5	6.4	7.1

Metric Performance Data: MV-KF2 / MV-KFS2

Thread	M2	M2.5	M3	M3.5	M4	M5
Test sheet FR4 fiberglass (thickness)	1.5mm	1.5mm	1.5mm	1.5mm	1.5mm	1.5mm
Installation (kN)	2.2	2.2	2.2	2.2	2.2	2.2
Torsional resistance (Nm)	1.36	1.36	1.36	2.06	3.75	4.55
Pushout (N)	200	200	200	210	335	355

These tests have been conducted in laboratory conditions, these figures should therefore be used for guidance only.

Mob : 9483389951 | Off : 9901633822 | support@mvdfasteners.com | mvdfasteners@gmail.com

693/186/16 | Kanika Nagar | Kachanayakana Halli | Bommasandra Ind. Area | Bangalore - 99