



# ZENCO INDUSTRIES

A3, Niemall Market, PCNTDA, Chikhali Road, Purnanagar,

Pune -411018.

Email : zenco.sales@gmail.com Mob : +91 8850364700

## **technical specification**

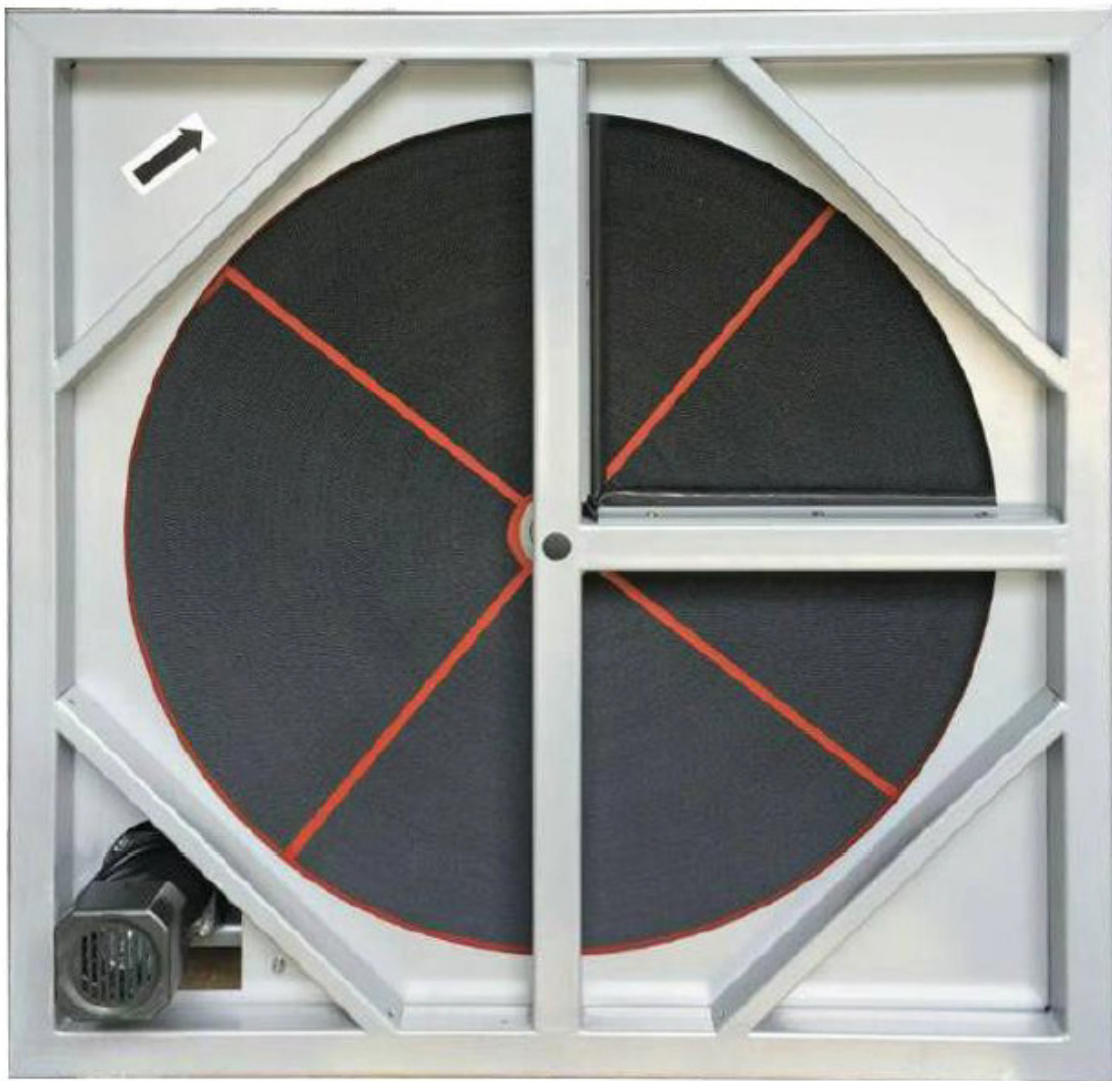

# Contents

I . Product principle .....	2
II . PSS performance.....	3
III. Application.....	7
IV. Application methods and characteristics .....	8
V . Product structure and the mechanical dimensions.....	10
VI. Introduction of the flange and box .....	14
1. Material of the box .....	14
2. Drive System .....	14
3. Sealing strip.....	15
VII. Manual .....	15
1. Rotor in the dehumidifier in normal use .....	15
2. Rotor's frame .....	15
3. Rotor's protection .....	17
4. Rotor's inspection.....	17
5. Rotor's maintenance: .....	17
6. Rotor's cleaning: .....	18
7. Sealing strip's inspection: .....	19
8. Replacement of the sealing: .....	19
VIII. Technical data curve&pressure loss: .....	20

## I . Product principle

Desiccant rotor is the core component of dehumidifier, it is made of special ceramic fiber carrier and adsorbent compound; Adsorption materials such as silica gel microstructure with chemical bond form solid and inorganic fiber crystallization together. The two sides of the wheel are divided into two areas by the special sealing device: the processing area and the regeneration area; When the dehumidified air passes through the processing area of the rotor, the water vapor of the humid air is adsorbed by the adsorbent of the rotor, and the dry air is sucked into the rotating area of the rotor. The processed fan is sent to the space needing to be treated, while the slowly rotating wheel turns the saturated water vapor into the regeneration area; the high-temperature air blown back in the regeneration area desorbs the moisture adsorbed in the rotor. The fan is discharged out of the room, so that the rotor to restore the ability to absorb moisture to complete the regeneration process, the rotor continues to rotate, the dehumidification and regeneration cycle again and again to ensure sustained and stable rotor dehumidification state.

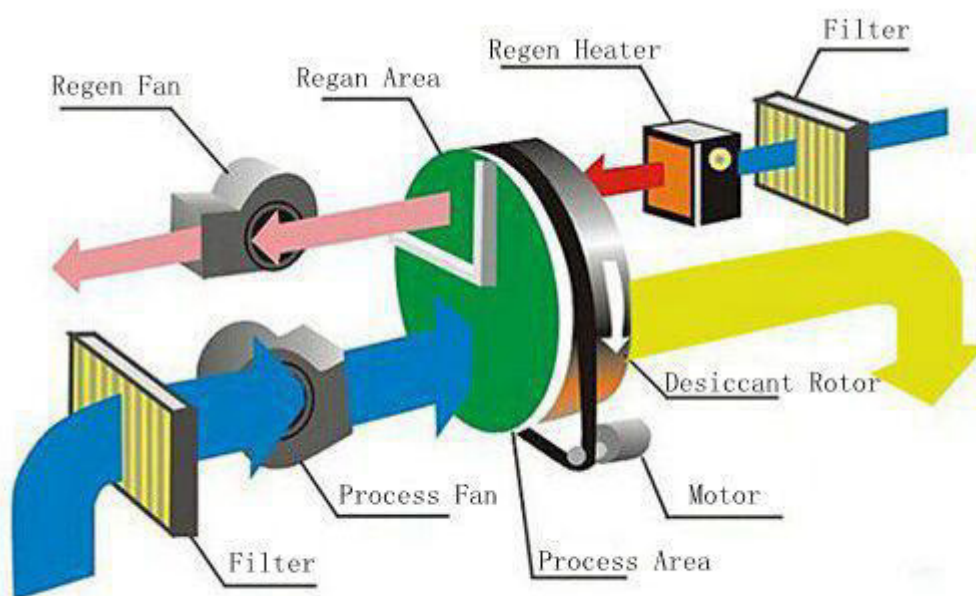
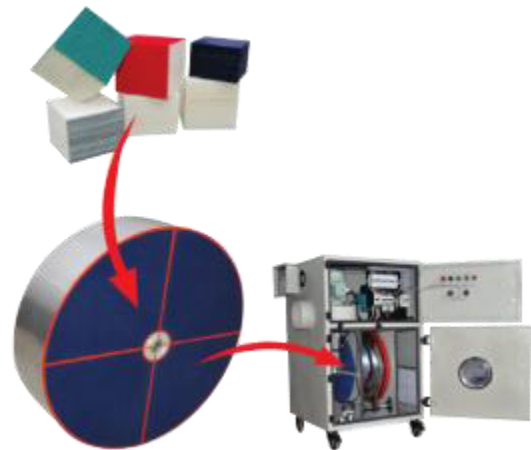

## II . PSS performance

**1. Material composition:** Special inorganic fiber substrate binder processed into a honeycomb, special inorganic fiber surface contains a large number of hydrophilic hydroxyl groups and inorganic silicate through rigorous and complicated process to the chemical bond firmly solidified together, will not fall off;

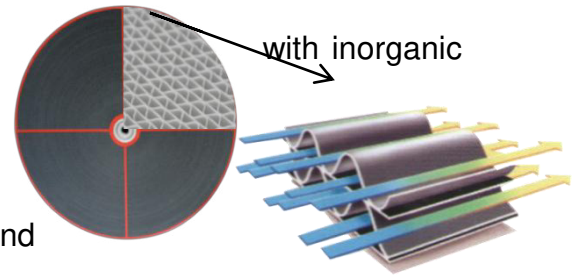

**2. Physical properties:** High adsorption performance, high surface strength, can be cleaned, can not afford to powder, no pollution;

**3. Chemical properties:** Chemical stability, but will react with alkali and hydrofluoric acid, avoid contact with such substances (avoid refrigerant leakage, strong alkali corrosion, hydrofluoric acid mist corrosion);

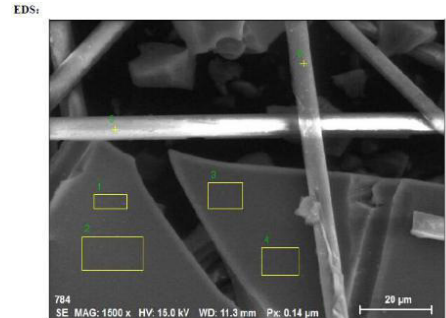

**4. Microscopic adsorption principle :** The adsorption between the silica adsorbent and the adsorbate is mainly a physical effect. This interaction includes the van der Waals interaction between the silica gel and the adsorbate molecules, and the hydrogen bonding between the silica hydrogens on the silica surface and the adsorbate. This adsorption is reversible adsorption, so the adsorbent in use can be repeated regeneration.

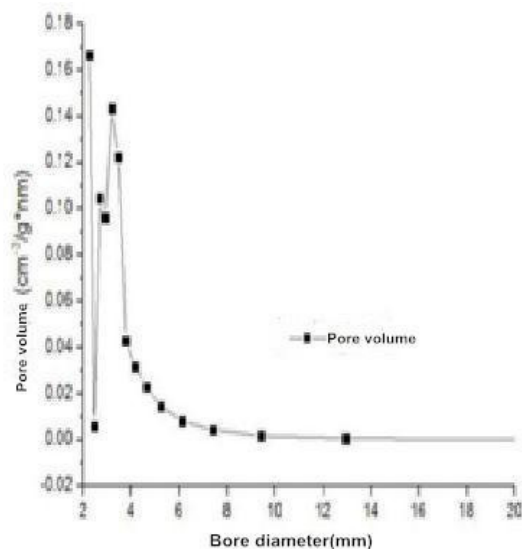
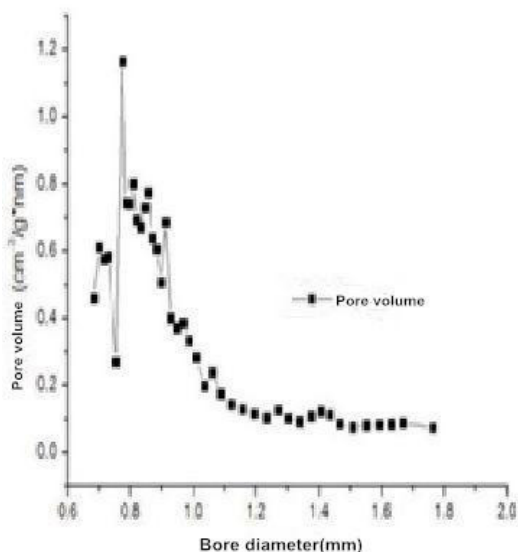
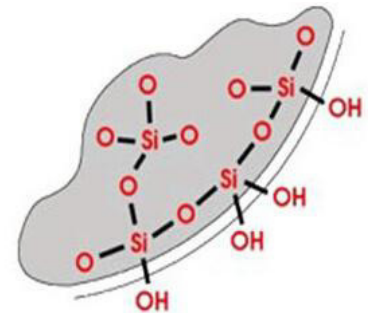

**5. Product quality and level:** Through a large number of orthogonal experiments and pilot production with many advanced production equipment, the world's leading control instruments, meters and systems to help, we get a high adsorption performance of the silica gel rotor products. In the surface adsorption pore distribution, the overall specific surface *area*, the heat transfer properties of materials and other basic research have reached the world leading level.

**6. Fire performance:** combustion index and smoke index are 0, the data are tested by ASTM E-84 standard.



**7. Surface strength:** 700N/cm<sup>2</sup> {70kgf/cm<sup>2</sup>}

**8. Coating performance description:** is from **AkzoNobel** or **SHERWIN-WILLIAMS(US)**, high temperature resistant, weather resistance, wear-resistant, anti-corrosion, no smell.

**9. Physical parameters:**

Name	data
Dry state's density (kg/m <sup>3</sup> )	240
Surface strength (N/cm <sup>2</sup> {kgf/cm <sup>2</sup> })	700 {70}
specific surface <i>area</i> (m <sup>2</sup> /g: BET)	735
Standard regeneration temperature (°C)	120—160°C

**10. Precautions for Silica Adsorption Material:**

- ① Silicone does not dissolve in water and any solvent, non-toxic and tasteless. Therefore, rinse with water and organic solvent maintenance.
- ② Silica gel can not only adsorb water vapor, but also can absorb SO<sub>2</sub>, H<sub>2</sub>S, NO<sub>x</sub> and other polar gases. But after water absorption, it will reduce the adsorption of other gases.
- ③ The adsorption material can adsorb a small amount of n-alkanes, and does not adsorb branched-chain alkanes.
- ④ Should be avoided in extremely harsh environments, such as dust, organic exhaust gas types, high content of the environment.
- ⑤ Before the rotor to add filters to capture solid particles in the air or very viscous compounds such as difficult to reproduce the material, otherwise, after the long running, these

substances is bound to reduce the adsorption capacity of the rotor.

⑥ Rotor also has a certain capacity of air purification, in the process of adsorption it will be adsorbed in the air trace volatile organic compounds (VOC), such as toluene, ethanol, acetaldehyde, trichloroethane.

(Note: There are electronics industry customers point out that turn on the rotor after a long time, there is a large odor may be because of this reason. The electronics industry workshop air environment is complex, generally containing a variety of volatile organic compounds, even if the concentration is not high, but After being stored for a long time, the stored rotor is enriched and concentrated, and the concentration increases, and the regenerative heating causes the gas to devolatilize in a short period of time.

#### 11. Adsorption properties of silica gel adsorption materials:

① Rich pore structure and high specific surface area makes it has excellent adsorption performance, is widely used as desiccant and adsorbent. The adsorption activity depends mainly on pore structure and specific surface area.

② Active silica gel pore surface has a large number of hydroxyl, with a certain polarity, is a polar adsorbent, can preferentially adsorb polar molecules such as H<sub>2</sub>O, SO<sub>2</sub>, H<sub>2</sub>S, NO<sub>x</sub>, etc.

③ Activated silica gel is hydrophilic and can adsorb a lot of water (up to 50% of its own weight). As a desiccant, it adsorbs other gases in addition to water vapor, but after the water absorption, the adsorption capacity of other gases will be reduced.

④ Rotor also has a certain capacity of air purification, in the process of adsorption it will be adsorbed in the air of trace amounts of volatile organic compounds.

⑤ A new generation of metal-doped silica gel due to the formation of M (metal) -O-S bond, enhanced affinity for water, able to absorb more water. The adsorption quantity relative to traditional silica gel has the significantly increased, the heat resistance and mechanical strength also increase greatly.

⑥ Since a n-alkane molecule can be adsorbed by multiple active sites on the surface of the alumina, the longer the n-alkane chain is, the stronger its adsorption on the alumina is. Therefore, a new generation of metal modified silica gel adsorbent can adsorb n-alkane.

## 12. Analysis of product life:

- ① The use of inorganic fiber substrate, high temperature, corrosion resistance, long-term use is not aging.
- ② Adsorbent through a special process solid crystal growth in the inorganic fiber substrate surface and pores in the reaction occurred in the substrate, the substrate surface and rich in a large number of hydrophilic hydroxyl groups, therefore, the adsorbent and substrate affinity is good, Combined with a strong, long-term use can not afford to powder.
- ③ Traditional silica gel adsorption material, for a long time in high temperature regenerative environment prone channel melting, collapse, jams, preparation of the wheel of life. The new type of metal-doped silica gel adsorbent, due to the formation of MO-Si bond (M on behalf of the doping metal), the surface pore skeleton support greatly enhanced pore structure is not easily damaged; The loss of sensible heat, slow the process of repeated high-temperature damage to the adsorption material, the preparation of the wheel life greatly extended.
- ④ Due to the formation of M-O-Si bond (M represents doping metal), the support of the pore structure of the new type of metal-doped silica gel adsorbent is greatly enhanced, that is, the mechanical strength is greatly enhanced, good for long-term use. In short, from the substrate, the adsorption material generation process, the absorption of heat-resistant properties of materials and mechanical properties of comprehensive analysis, rotor products have a longer service life. it is up to several years or even years.
- ⑤ Product adsorption material properties of stability, product maintenance and maintenance are simple, are conducive to long-term use.

### III. Application

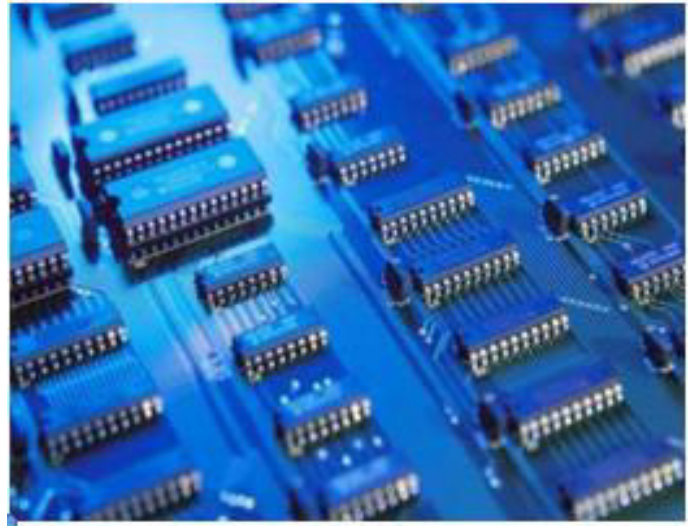
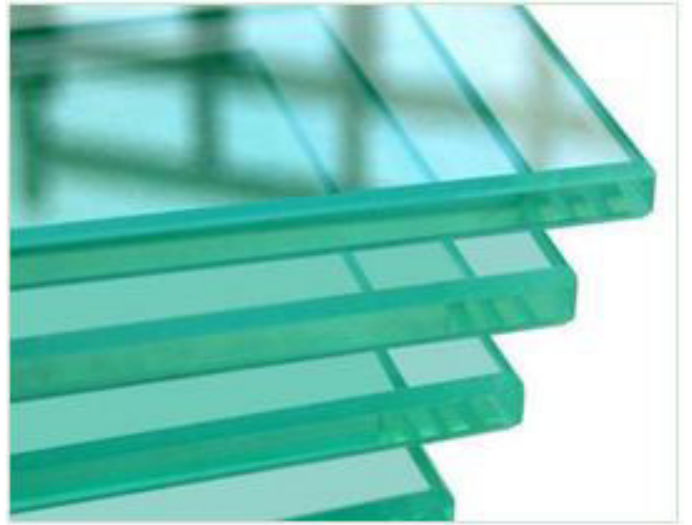



## IV. Application methods and characteristics

PSS desiccant rotor can be applied to many fields of industry, agriculture, commerce and human life under different thickness and different application conditions. The different application of PSS desiccant rotor is according to the different countries and regions.

a. There are the following partitions:

**1:3** For most areas of dehumidification, it can meet the normal state of the dehumidification operation, can be used for new wind, a return air and the second return air.

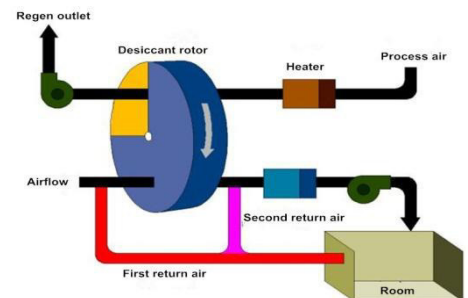

**1:1:2** It is suitable for many areas of dehumidification and AHU. It can effectively utilize the waste heat from the air cooling of rotor to improve the working surface area. and reduce the heating energy of the regenerative air. It is used in the small rotor dehumidifier.

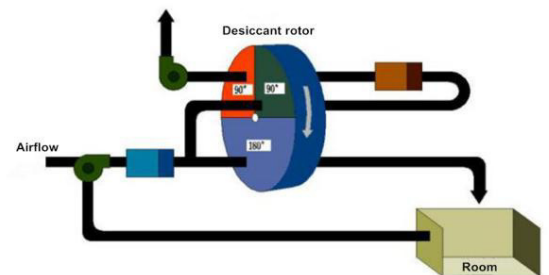

**30°:70°:260°** It can be used in many areas of dehumidification and AHU. It can effectively utilize the waste heat of the air cooling of rotor to improve the adsorption surface of the rotor and reduce the heating energy of regenerative air. The regeneration air can be reduced to 20% -40% of the process air.

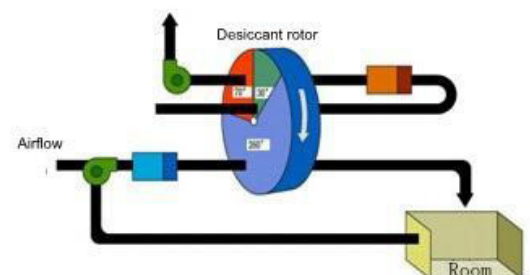

**1:1:6** It is suitable for treating low dew point, effectively utilizing the waste heat in the air cooling area of rotor, improving the working surface area of the rotor adsorption, reducing the heating energy consumption of regenerative air.

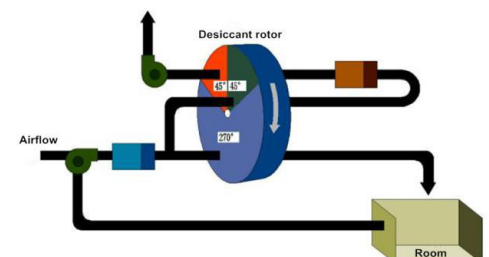

**1:1:8** It can be used to deal with the low dew point of low temperature and low temperature. It can effectively utilize the waste heat of the air cooling of the rotor to improve the working surface area and reduce the heating energy of the regenerative air.

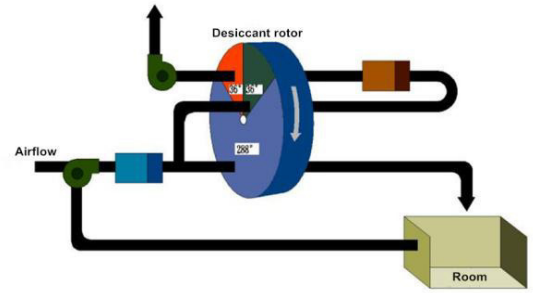

**1:1:10** It can be used to deal with the low dew point of low temperature and low temperature. It can effectively utilize the waste heat of the air cooling of rotor to improve the working surface area and reduce the heating energy of the regenerative air.

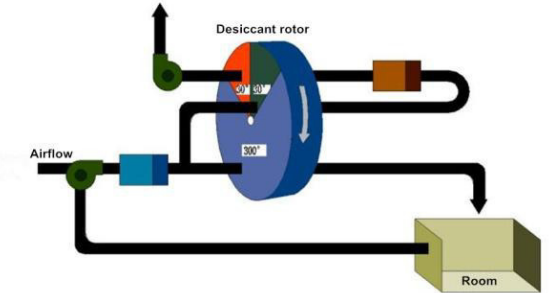

**Four partition application characteristics :**

Pre-cooling treatment area, surface area increased, the wind through the air duct to the regenerative area preheating energy-saving two purposes. It need to increase the circulating fan for general low dew point dew.

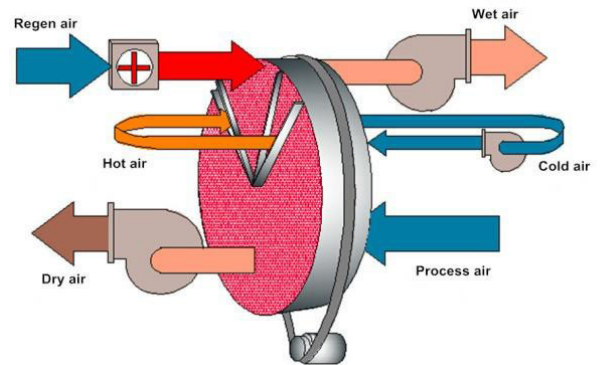

## V. Product structure and mechanical dimensions

In addition to the standard size (diameter and thickness), we can also provide non-standard diameter and thickness of the rotor, such as 50 mm, 65 mm, 100 mm and 150 mm.

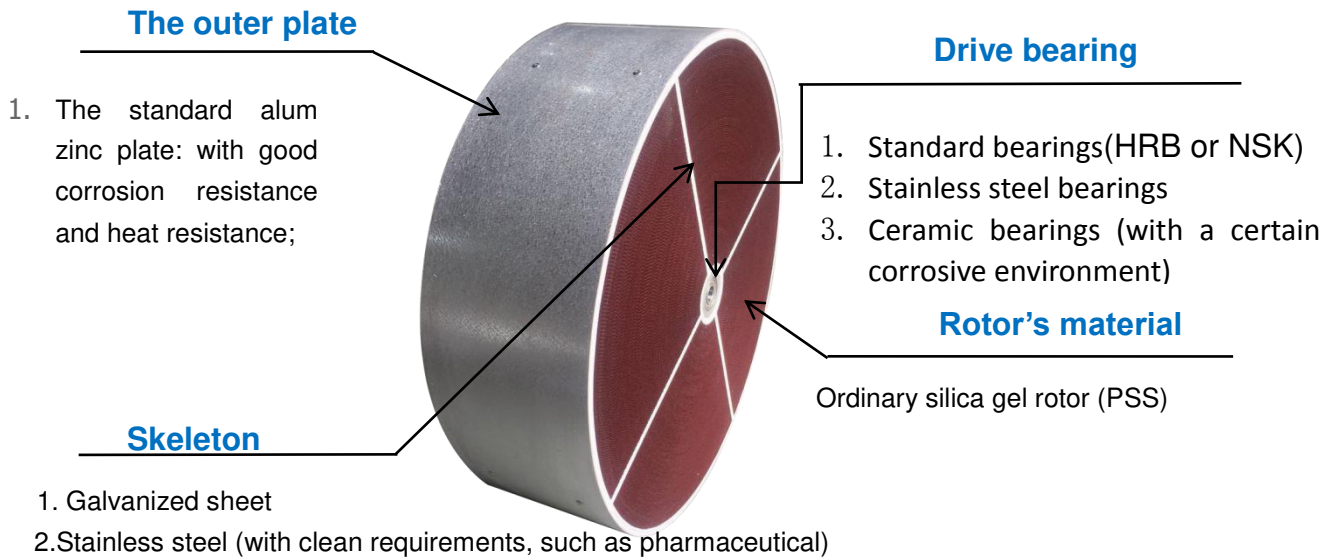

### Two areas small rotor

A(Dia.)	B (TK)	C (Bearing/ inner hole)	D(Shaft OD)	E(Plate)	F (Outer plate)	G(rivet)
180	200、300、400	6204/20	50	Galvanized sheet	304/ alum coated zinc plate	Stainless steel
250	200、300、400	6204/20	50	Galvanized sheet	304/ alum coated zinc plate	Stainless steel
300-350	200、300、400	6204/20	50	Galvanized sheet	304/ alum coated zinc plate	Stainless steel
440	300、400	6204/20	50	Galvanized sheet	304/ alum coated zinc plate t	Stainless steel
550	300、400	6204/20	50	Galvanized sheet	304/ alum coated zinc plate	Stainless steel

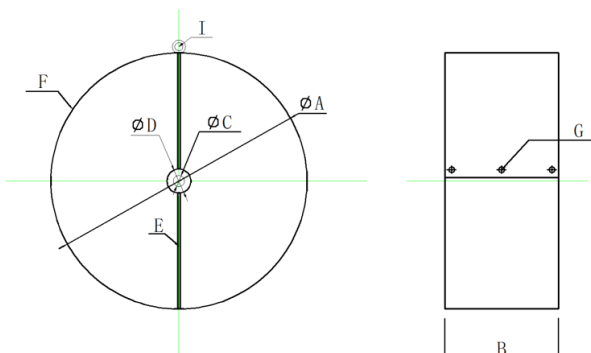

## Four areas rotor

A(Dia.)	B (TK)	C (Bearing/ inner hole)	D(Shaft OD)	E(Plate)	F (Outer plate)	G(rivet)	I(Lifting rings)
450	100、200	6204/20	50	Galvanized sheet	alum coated zinc plate	Stainless steel	—
550	100、200	6204/20	50	Galvanized sheet	alum coated zinc plate	Stainless steel	—
600-650	200、400	6204/20	70	Galvanized sheet	alum coated zinc plate	Stainless steel	—
700-770	200、400	6204/20	70	Galvanized sheet	alum coated zinc plate	Stainless steel	—
800-850	200、400	6204/20	70	Galvanized sheet	alum coated zinc plate	Stainless steel	—
965	200、400	6204/20	100	Galvanized sheet	alum coated zinc plate	Stainless steel	√
1050-1070	200、400	6204/20	100	Galvanized sheet	alum coated zinc plate	Stainless steel	√
1200-1250	200、400	6206/30	150	Galvanized sheet	alum coated zinc plate	Stainless steel	√
1370	200、400	6206/30	150	Galvanized sheet	alum coated zinc plate	Stainless steel	√

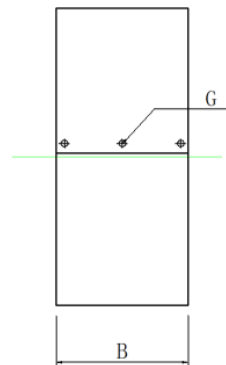
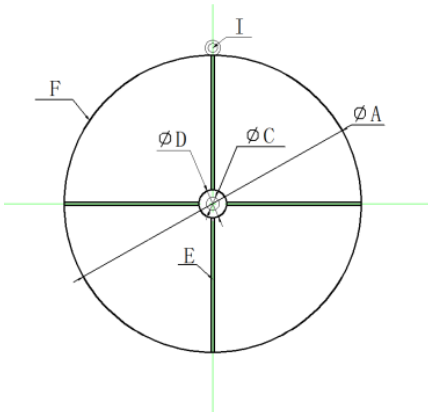

### Six areas rotor

A(Dia.)	B (TK)	C ( Bearing/ inner hole)	D(Shaft OD)	E(Plate)	F ( Outer plate)	G(rivet)	H( Reinforce ment plate)	I(Lifting rings)
1500-1525	200、400	6206/30	150	Galvanized sheet	alum coated zinc plate	Stainless steel	√	√
1650	200、400	6206/30	150	Galvanized sheet	alum coated zinc plate	Stainless steel	√	√

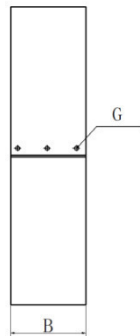
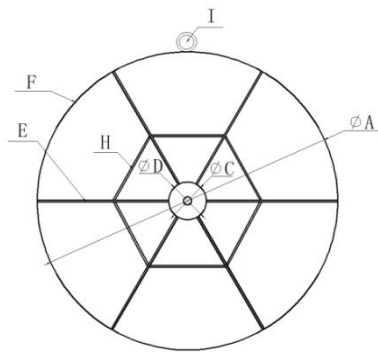

### Eight areas rotor

A(Dia.)	B (TK)	C ( Bearing/ inner hole)	D(Shaft OD)	E(Plate)	F ( Outer plate)	G(rivet)	H( Reinforce ment plate)	I(Lifting rings)
1730	200、400	6206/30	240	Galvanized sheet	alum coated zinc plate	Stainless steel	√	√
1940	200、400	6206/30	240	Galvanized sheet	alum coated zinc plate	Stainless steel	√	√
2000	200、400	6206/30	240	Galvanized sheet	alum coated zinc plate	Stainless steel	√	√
2200	200、400	6206/30	240	Galvanized sheet	alum coated zinc plate	Stainless steel	√	√
2400	200、400	6206/30	240	Galvanized sheet	alum coated zinc plate	Stainless steel	√	√
2650	200、400	6206/30	240	Galvanized sheet	alum coated zinc plate	Stainless steel	√	√
3000	200、400	6206/30	240	Galvanized sheet	alum coated zinc plate	Stainless steel	√	√

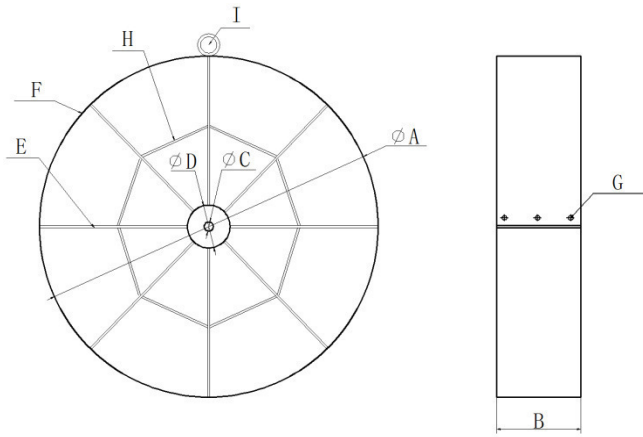

If the above wheel is equipped with flange, the flange material is:

- (1) Hot dip galvanized angle steel flanges
- (2) Stainless steel angle flange



### Big rotor separate field assembly steps:

Recommended diameter more than 2200 to use the split type, also can customize according to customer's requirements.

1. The second half with flange plate put the central axis on the shelf



2. Combined the upper and lower parts



4. Fixed the outer plate

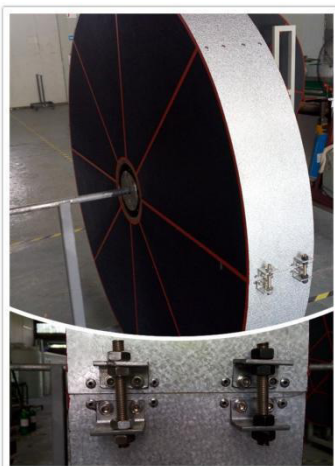

3. Assemble the flange plate



## VI. Introduction of the flange and box

### 1. Cassette's material

(1) **Cold drawn square tube welding, high temperature paint**

Has a good structure rigidity, spraying anti-corrosion treatment as a whole  
To ensure that the corrosion resistance of the cassette and service life

Rotor seal is a silicone rubber plus Teflon compound  
flat strip seal (high temperature, low friction coefficient)

Synchronous belt or stainless steel chain transmission  
Geared motor

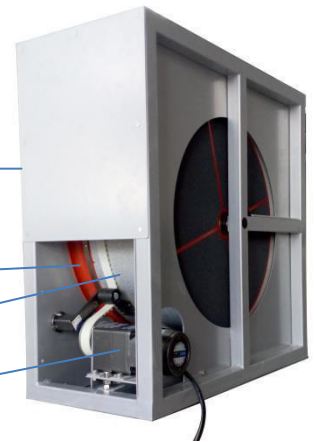

(2) **Alum zinc plate bending stitching**

Smooth surface, good heat resistance

Has excellent corrosion resistance,  
can extend the service life

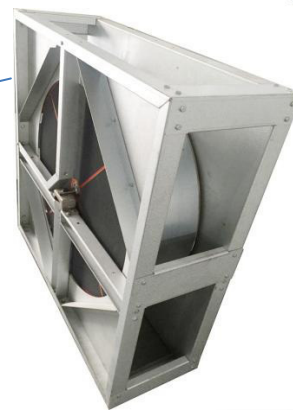

(3) **Stainless steel plate bending welding**

Beautiful, high strength, moisture-proof, not easily deformed

Have better corrosion resistance and heat resistance

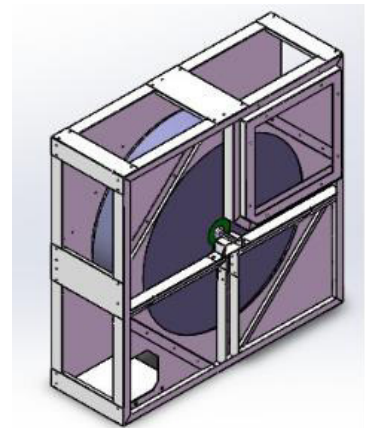

### 2. Drive System

The drive system is composed of timing belt or chain and synchronous rotor or sprocket and gear motor (three phase, 380V, 50Hz). The gear motor is made in Taiwan (applicable environment is  $-10 \sim 40^{\circ}$ ). The driving motor is fixed on a motor bottom plate which can swing around the shaft, and the tensioning mechanism is made of damping rubber.



### 3. Sealing strip

The sealing strip of the rotor is composed of materials resistant to high temperature, abrasion resistance. The seal for the periphery of the rotor is silicone rubber plus Teflon compound flat strip seal. It is used for wind and regeneration Sealed between the air partition is a hollow P-type seal or flat seal.



## VII. Manual

### 1. Rotor in the dehumidifier in normal use

1) Requirements for the rotor frame: strength and hardness to be achieved, the internal structure of the horizontal and vertical, making the sealing better.

2) For the adjustment of air volume, it is very difficult to adjust the air flow with the anemometer to regulate the air flow. It is suggested to display the air pressure value before and after the rotor. The pressure can be controlled by the sampling tube. We provide the rotor resistance curve can know its face wind speed, and then also know the actual air flow through the rotor.

3) For the regeneration heating requirements, increase the stainless steel orifice, placed in the rotor regeneration area in order to electrical heating control on rotor damage, can also increase the UPS power, renewable fan and rotor motor waste heat blown away .

4) For the requirements of the rotor drive: timing belt or stainless steel chain, sprocket drive, it is recommended to use the bearing seat fixed rotor.

5) For the sealing requirements: it is recommended that (to be with the framework of the rotor's flange), making them better sealing effect.



### 2. Rotor's frame



1) Fixed: The cassette and the unit as a whole fixed together, simple assembly, low cost, but maintenance is a trouble.

2) The cassette and the two ends of the unit are made of double-layer sealed sheet metal structure according to the frame function area, and the pulley is installed at the bottom of the cassette so as to be easily removed. Two kinds of structure as below:

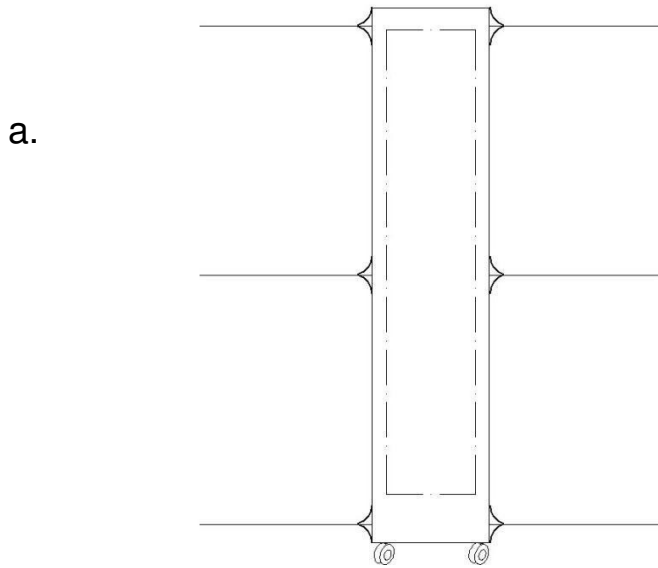

The double-layer sealing strip is pressed into rotor's cassette, in close contact with the double-side sealing strips which is fixed on the unit sheet metal structure when push into.

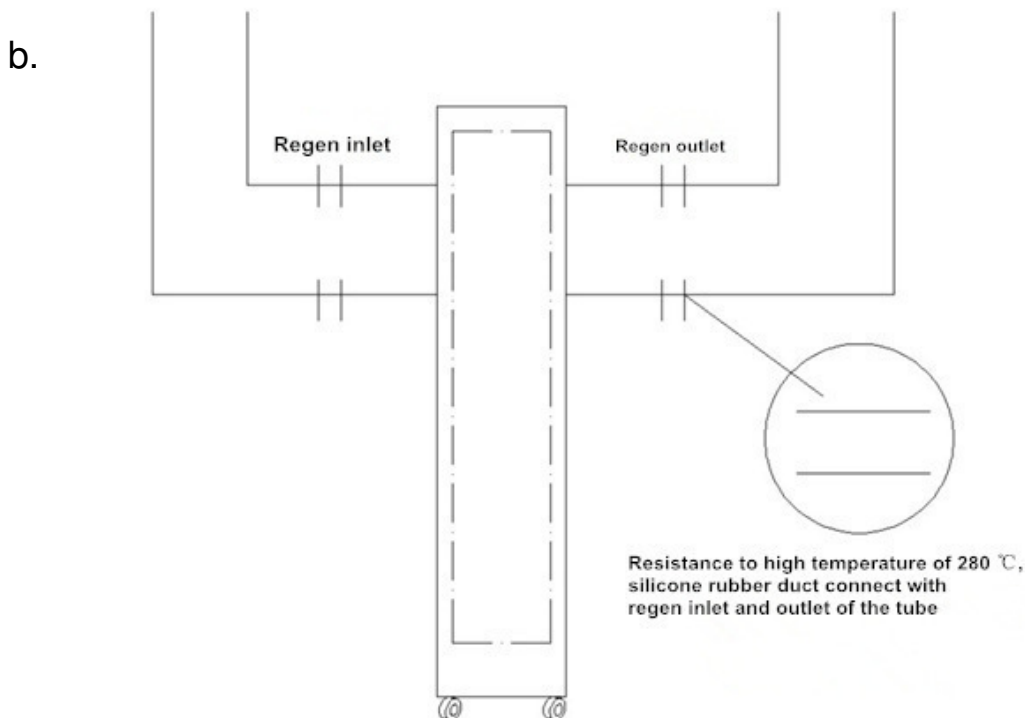

### **3. Rotor's protection**

In rotor inlet (process and regeneration air) need to add the effect filter, in order to prevent the dust plug desiccant medium pore to lower wind resistance and dehumidification efficiency.

The dehumidifier used in the high humidity environment should be installed behind the front cooler effective flap to prevent the condensate water directly into the rotor body. When using steam as a regenerative heat source, to prevent from damage to the rotor heat exchanger leakage of steam.

In the dehumidifier rotor regeneration zone need to set the temperature probe, and has a high temperature (more than 180 degrees Celsius) alarm and automatically adjust or cut off the heater power supply function; also set the rotor running sensor probe, once the rotor unexpectedly stopped Operation, immediately alarm and immediately cut off the heater power to prevent the high temperature air flow for a long time the regeneration zone of the media and baking damage.

### **4. Rotor's inspection**

Carefully check the surface of the rotor for local fading, damage and contaminants are blocked. Under normal circumstances, the rotor surface color is blue, after a period of use, some pollutants in the rotor surface deposition led to its color faded into brown. If the surface color turns pink, it indicates that the rotor has been subjected to high temperatures (above 220 degrees Celsius). Once the rotor surface has been damaged, it will appear dark brown patches.

Desiccant-rotor based medium occasionally appear some small crack, the crack just makes the rotor some ugly, but it is no effect for the performance of the rotor. The easiest way to repair these ugly crack is to embed high temperature resistant silica gel rubber.

### **5. Rotor's maintenance**

For the small gaps and defects on the rotor can be repaired on site: all small gaps can be filled with high temperature silica gel adhesive filling, and then make the surface smooth; for small pits and scratches, can be provided by the company a special topcoat or coated

with a high temperature silica gel adhesive filled. For larger damage to the dehumidifier medium or subject to serious pollution of the rotor will need to be sent to the maintenance of the company or completely replace the desiccant material.

## 6. Rotor's cleaning

It is necessary to periodically remove dust and debris accumulated on the surface of the rotor. Usually dehumidifiers are equipped with air pressure probe, it can display the pressure difference before and after the rotor. When the pressure difference by more than 125% of the value of the new rotor differential pressure, the rotor needs to be cleaned as follows:

(1) If the dirt attached on the surface of rotor, can use a brush with a vacuum cleaner to clean up;

(2) If the dirt into desiccant medium of the rotor, it should be using high pressure air to blow it out.

(3) If the dirt into the medium and has set up a stick in the medium surface, cleaning should take the following steps:

① Turn off the regenerative heater and allow the high humidity process air (60% relative humidity) to continue through the rotor, and as the rotor continues to run so that the rotor is gradually saturated with moisture; if the air is too dry, you need to add its moisture. This process takes about more than an hour.

② According to the properties of dirt, the rotor into with cleaner water, but the PH value should not be greater than 7, alkaline solution can be damaged by silica gel rotor material. If it is oily contaminants should put it in the aqueous solution of xylene. The rotor was swung up and down in the solution for about fifteen minutes and then removed.

③ Remove the wheel to be flat after a while, so that the solution flowed out from the media.

④ With high pressure air will remain in the pores of the medium solution blowing.

⑤ Re-install the rotor into the box of dehumidifier, start the motor and enable regenerative heating to operate the system for at least one hour.

Note:

1. the beginning of operation in the dry air and wet air exports will have a higher

concentration of moisture discharge; if you use the solvent, the smell will remain in the air for several days.

2. For some oil or some viscous heavy pollution, if you want to wash out of the rotor is almost impossible, just only to change the rotor. The desiccant function of the cleaned rotor can be partially restored, but not all of it can be recovered.

## **7. Sealing strip's inspection:**

The sealing strip of the rotor is made of imported materials with high temperature resistance and abrasion resistance. The compound seal strip of rotor's rim with silicone rubber and Teflon coating. And the sealing strip between regeneration air and processing air area is the hollow P-type seal. Check the condition of the sealing strip to ensure good sealing between the surface of the rotor and the side plates of the rotor box. It is normal for a P-type seal to be used in a compartmentalized seal for a long period of time with a small amount of black debris. But if a large number of debris, which shows that the seal has been excessive wear and need to be replaced. At the same time should also carefully check the rotor box and the dehumidifier box sealed between the situation, any significant leakage will affect the desiccant effect of dehumidifier.

## **8. Replacement of the sealing:**

All seals can be replaced on the rotor's box without removing the rotor: the flat belt seal around the runner is secured to the outer ring of the rotor with a stainless steel strap and can be replaced by unscrewing the screw and changed back into a new sealing strip; P-seal between the partition is fixed on the rotor's frame by pressure plate and screw, unscrew the screw can also be replaced with a new seal. If you want to replace the original new seal, can order from our Company.

## VIII. Technical data curve & pressure loss:

**Resistance of different TK (Unit: Pa)**

TK	Each area resistance	Air flow								
		1m/s	1.5m/s	2m/s	2.5m/s	3m/s	3.5m/s	4m/s	4.5m/s	
200mm	Processing area resistance	24°C	68	103	140	182	220	262	305	346
		12°C	65	99	134	175	211	252	293	332
		15°C	66	100	136	177	214	254	296	336
		18°C	67	101	137	179	216	257	299	339
	Regeneration area resistance	100°C	85	129	176	229	276	329	383	435
150mm	Processing area resistance	24°C	50	76	107	141	174	210	250	285
		12°C	48	73	103	135	167	202	240	274
		15°C	49	74	104	137	169	204	243	277
		18°C	49	75	105	138	171	206	245	280
	Regeneration area resistance	100°C	63	96	134	177	219	264	314	358
100mm	Processing area resistance	24°C	35	52	72	93	116	140	164	190
		12°C	34	50	69	89	111	134	158	182
		15°C	34	50	70	90	113	136	159	184
		18°C	34	51	71	91	114	137	161	186
	Regeneration area resistance	100°C	44	65	90	117	146	176	206	239
50mm	Processing area resistance	24°C	18	29	40	53	67	81	97	113
		12°C	17	28	38	51	64	78	93	109
		15°C	17	28	39	51	65	79	94	110
		18°C	18	28	39	52	66	79	95	111
	Regeneration area resistance	100°C	23	36	50	67	84	102	122	142



# ZENCO INDUSTRIES

A3, Niemall Market, PCNTDA, Chikhali Road, Purnanagar,

Pune -411018.

Email : zenco.sales@gmail.com Mob : +91 8850364700

## **technical specification**

