

FC FLANGED PRESSURE SWITCHES

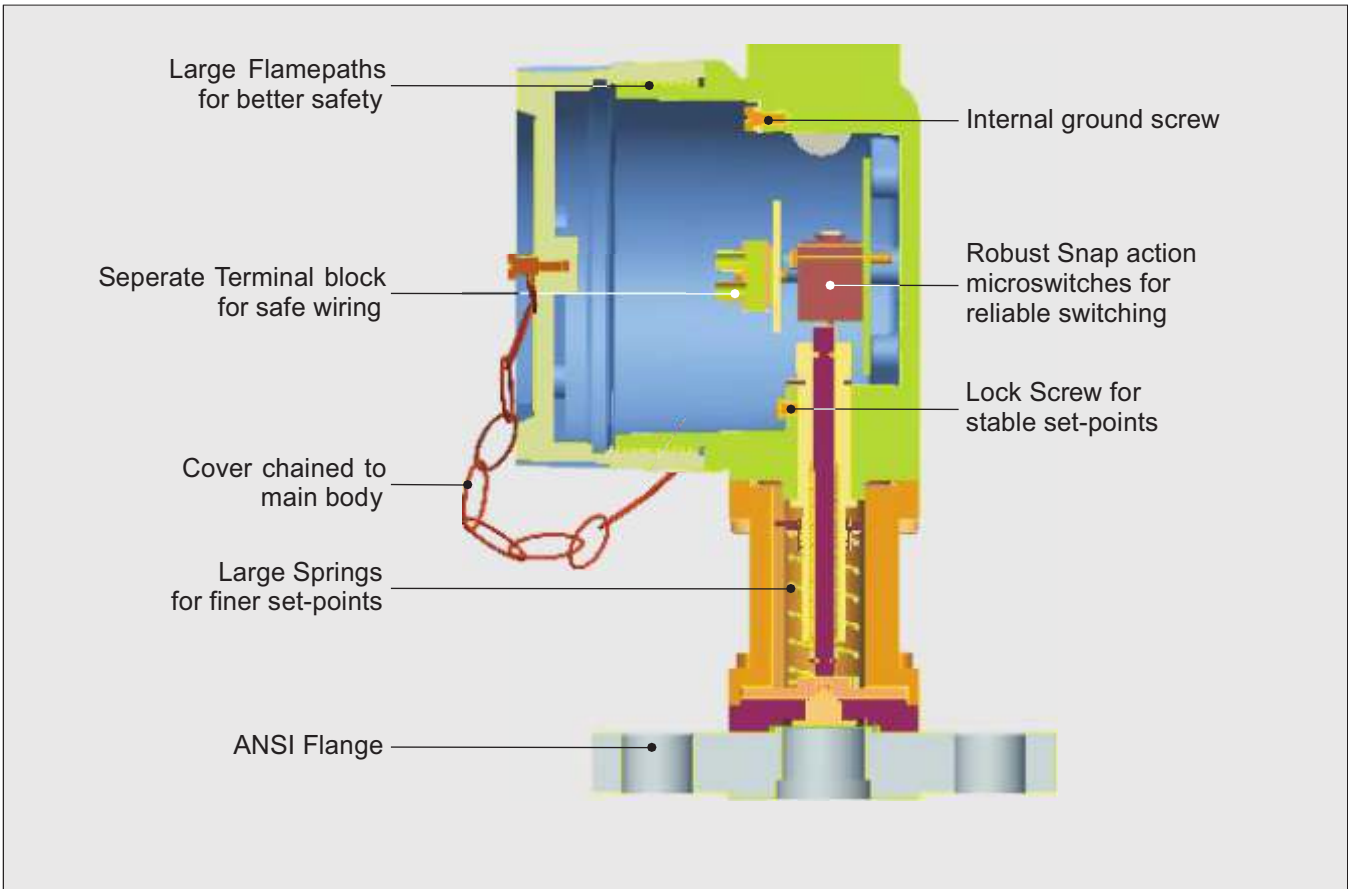

Approximate Weight :

Pressure switches with Aluminium enclosure : Varies with flange, please consult sales office
 Pressure switches with Grey CI enclosure : Varies with flange, please consult sales office
 Pressure switches with SS enclosure : Varies with flange, please consult sales office

Electrical Connection :

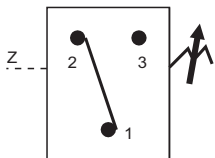

Some Applications :

For slurry, colloidal solutions, corrosive & non-corrosive working media (unclean working media), etc.

FLANGED PRESSURE SWITCHES FC



PRESSURE CAPSULE DETAILS

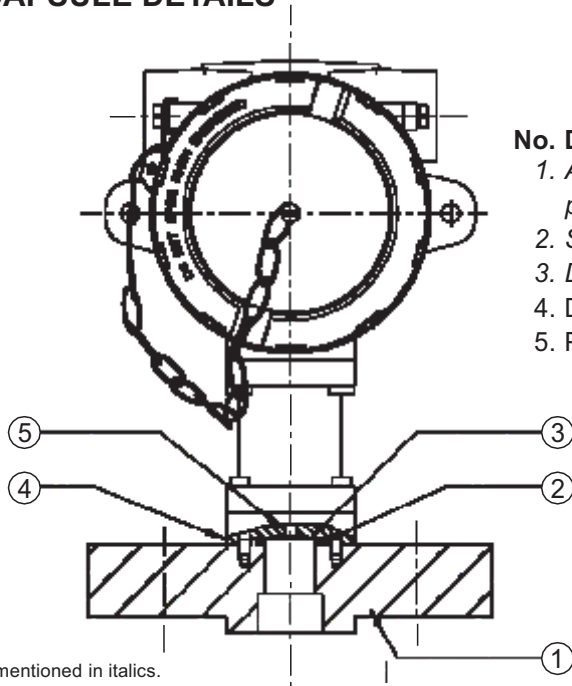

No. Description

1. ANSI FLANGE to your specifications
please refer table for possible combinations
2. Sealing Ring
3. Diaphragm
4. Disc
5. Plunger

Note : *wetted parts* are mentioned in italics.

INSTALLATION DRAWING

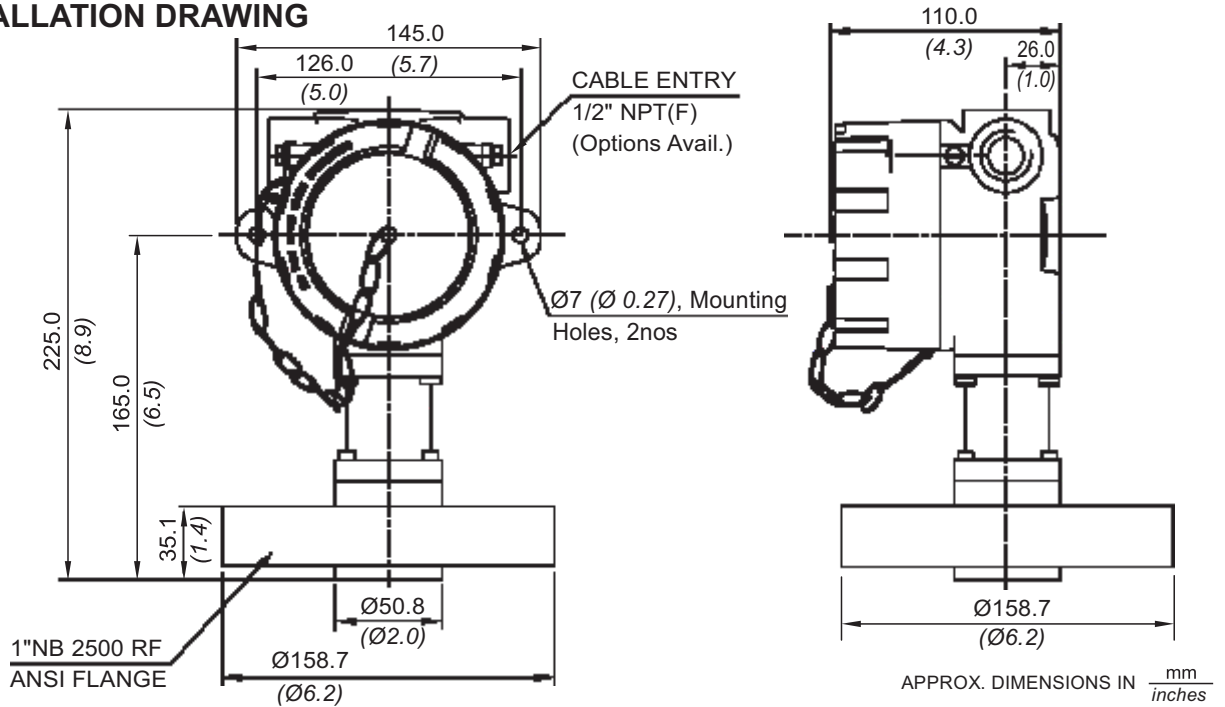

FC FLANGED PRESSURE SWITCHES

RANGE SELECTION TABLE

Range Code	Range bar (psi)	Differential* bar (psi)	Maximum Working Pressure bar (psi)
		Approximate Maximum for "A1" microswitch	
H01	0.1 - 1.0 (1.45 - 14.50)	0.10 (1.45)	As per the class of flange Please consult Sales Office in case you need clarification on availability of maximum working pressure for a particular range.
H02	0.1 - 1.5 (1.45 - 21.76)	0.12 (1.74)	
H03	0.2 - 2.6 (2.90 - 37.71)	0.15 (2.17)	
H04	0.2 - 3.6 (2.90 - 52.21)	0.20 (2.90)	
H07	0.5 - 7.0 (7.25 - 101.50)	0.20 (2.90)	
H10	0.5 - 10.0 (7.25 - 145.04)	0.40 (5.80)	
H15	1.0 - 15.0 (14.50 - 217.56)	0.50 (7.25)	
H30	5.0 - 25.0 (72.51 - 362.56)	1 (14.50)	
H4T	5 - 40 (72.51 - 580.15)	5 (72.51)	
H1H	10 - 100 (145.04 - 1450.38)	12 (174.05)	
H2H	7 - 200 (101.53 - 2900.76)	24 (348.09)	

* Minimum differential increases with setpoint (Graphs available on request)

* Differentials of microswitches A2 through A9 will vary. Differentials for A7 are typically twice that for A1 microswitch. Please indicate specifically the differential value in enquiry/order, when it is critical in your application.

FLANGE CODE TABLE (Please refer page no. 228 & 229 for more options)

	SS316L		Hastelloy C276		Monel		Titanium		Tantalum	
	RF*	FF*	RF*	FF*	RF*	FF*	RF*	FF*	RF*	FF*
150 #										
1" NB	AC	BS	DI	EY	GO	IE	JU	LK	NA	OQ
2" NB	AF	BV	DL	FB	GR	IH	JX	LN	ND	OT
300#										
1" NB	AI	BY	DO	FE	GU	IK	KA	LQ	NG	OW
2" NB	AL	CB	DR	FH	GX	IN	KD	LT	NJ	OZ
2500#										
1" NB	BM	DC	ES	GI	HY	JO	LE	MU	OK	QA
2" NB	BP	DF	EV	GL	IB	JR	LH	MX	ON	QD

*RF = Raised Face

*FF = Flat Face

RANGE AVAILABILITY AS PER BORE SIZES

	H01 to H04	H07	H10	H15	H30	H2T to H2H
1" NB	NA	Yes	Yes	Yes	Yes	Yes
2" NB	Yes	Yes	Yes	Yes	Yes	Yes

HOW TO ORDER FLAMEPROOF FLANGED PRESSURE SWITCHES

Group 1	Group 2	Group 3	Group 4	Group 5	Group 6	Group 7	Group 8
Non standard allocation	Gas Group Classification	Cable Entry Size	Switch Type	Range Code (values in bar)	Microswitch Type	Flange Size and Material	Diaphragm
<input type="checkbox"/> Reserved for non-standard options not covered in catalogue. Will be given by manufacturer, only after agreement of supply details with customer.	FC = Flameproof pressure switch, ATEX & IECEx approved, with Aluminium head as per IS/IEC 60079-1 for Gas Gr. IIC	1 = Al. head 1/2" NPT threads 2 = Al. head 3/4" NPT threads 3 = Al. head M20 x 1.5 threads 4 = Grey CI head 1/2" NPT threads 5 = Grey CI head 3/4" NPT threads 6 = Grey CI head M20 x 1.5 threads 7 = SS head 1/2" NPT threads 8 = SS head 3/4" NPT threads 9 = SS head M20 x 1.5 threads	A1 = ANSI Flanged pressure switch, fixed differential without scale A2 = ANSI Flanged pressure switch, fixed differential with scale in bar A3 = ANSI Flanged pressure switch, fixed differential with scale in psi	H01 = 0.1 - 1.0 H02 = 0.1 - 1.5 H03 = 0.2 - 2.6 H04 = 0.2 - 3.6 H07 = 0.5 - 7.0 H10 = 0.5 - 10.0 H15 = 1.0 - 15.0 H30 = 5.0 - 25.0 H4T = 5 - 40 H1H = 10 - 100 H2H = 7 - 200	A1 = General purpose microswitch rated at 15A; 250 VAC A2 = Hermetically sealed for corrosive environments A3 = gold plated contacts for low voltage applications A4 = DPDT configuration A5 = for high DC ratings A6 = elements with adjustable deadband A7 = 2SPDT switching elements A9 = General purpose microswitch rated at 5A; 250 VAC Please refer page no. 230 for more microswitch options * Please refer note under Range Selection Table	Please select as per Flange Code table For other classes and sizes please refer page no. 228 & 229	0 = Neoprene 1 = Teflon 2 = SS316L 3 = Hastelloy C 4 = Monel 400 5 = Titanium 6 = Tantalum

Continuous efforts for product development may necessitate changes in these details without notice

eg. A flameproof switch for gas group IIC, with 1/2" NPT cable entry in aluminium housing with an ANSI flange, having 0.5 bar to 7 bar pressure range, with 15 Amp. microswitch, 1" NB 150# RF SS316L flange & SS316L diaphragm shall be specified by

Group 1	Group 2	Group 3	Group 4	Group 5	Group 6	Group 7	Group 8
<input type="checkbox"/>	FC	1	A1	H07	A1	AC	2

Please specify full model number to avoid ambiguity. If only the first two groups are specified while ordering, uncalibrated switches with standard wetted parts and enclosures will be supplied.