

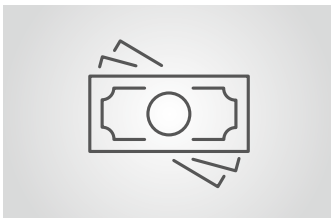

For rapid toll processing

Rapid, reliable, and economical processing of road users is essential when collecting toll charges at bridges, tunnels and on roads. Toll barriers from Magnetic have been specially designed for this situation. The innovative MHTM™ drive at the heart of the barriers is characterised by its speed, lack of maintenance and energy efficiency, and thus keeps long-term costs down. The Toll barriers can be adapted to meet individual requirements: there are five models with opening times of from

1.3–0.3 s, which can be equipped with a variety of control devices, flanges and barrier booms. All barrier boom types can be provided with swing-away flange. In the case of a collision with a vehicle, the barrier boom is released and can be manually re-engaged afterwards. This protects the barrier boom and the drive unit. There is also the optional auto-swing-away flange for the soft boom, which automatically re-engages after a collision with a vehicle.



Effective toll processing

Toll barriers from Magnetic are the optimum solution for all toll applications thanks to their speed, reliability and low operating costs.



Innovative drive technology

The MHTM™ drive unit operates without maintenance, energy-efficiently and quietly. Its high torque ensures best possible operation even under extreme weather conditions.

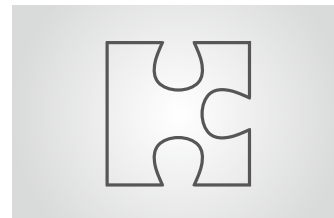

Individual configuration

Five models, three control units, three different barrier booms – the Toll barriers can be individually adapted to your requirements. Our staff would be pleased to advise you!

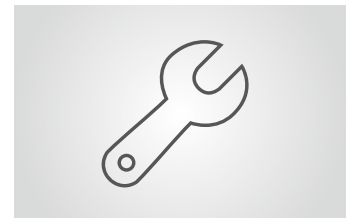

Easy access to components

Two simple hand movements suffice: easy access to the control system and drive unit by removing the hood and front panel. This increases user-friendliness and speeds up commissioning and servicing.

Toll

Toll barrier

- > Opening and closing times down to 0.3 s
- > Very low operating costs thanks to efficient and long-lived MHTM™ drive
- > Highly user-friendly and with optimum accessibility
- > Prizewinning design: German Design Award 2014 and red dot design award 2012
- > Designed for 10 million opening and closing cycles



Technical Data	Toll	Toll Pro	Toll Pro 2	Toll HighSpeed	Toll HighSpeed 2
Lane width	max. 3.0 m	max. 3.0 m	max. 3.0 m	max. 3.0 m	max. 3.2 m (with 2 barriers)
Opening/closing time	1.3 s	0.9 s	0.7 s	0.6 s	0.3 s
Power consumption	max. 55 W	max. 95 W	max. 225 W	max. 320 W	max. 450 W
Drive technology	MHTM™	MHTM™	MHTM™	MHTM™	MHTM™
Voltage	85–264 VAC, 50/60 Hz	85–264 VAC, 50/60 Hz	85–264 VAC, 50/60 Hz	85–264 VAC, 50/60 Hz	85–264 VAC, 50/60 Hz
Duty cycle	100 %	100 %	100 %	100 %	100 %
Housing dimensions (W x D x H)	315 x 360 x 1115 mm	315 x 360 x 1115 mm	315 x 360 x 1115 mm	315 x 360 x 1115 mm	315 x 360 x 1115 mm
Enclosure rating	IP 54	IP 54	IP 54	IP 54	IP 54
Temperature range	-30 bis +55 °C	-30 bis +55 °C	-30 bis +55 °C	-30 bis +55 °C	-30 bis +55 °C
Weight	approx. 42 kg	approx. 42 kg	approx. 43 kg	approx. 44 kg	approx. 44 kg

Features	Toll	Toll Pro	Toll Pro 2	Toll HighSpeed	Toll HighSpeed 2
Standard colour	RAL 2000	RAL 2000	RAL 2000	RAL 2000	RAL 2000
Barrier boom	3 models available	3 models available	3 models available	3 models available	2 models available
Control system	3 models available	3 models available	3 models available	3 models available	3 models available
Number of digital inputs	8	8	8	8	8
Input for safety light barrier with test	1	1	1	1	1
Number of relay/digital outputs	6/4	6/4	6/4	6/4	6/4
Closing speed	adjustable	adjustable	adjustable	adjustable	adjustable

Control systems	MGC without loop detector	MGC with loop detector	MGC Pro
2 detector channels		✓	✓
Adjustable inputs/outputs			✓
3 opening speeds			✓

Options	Toll	Toll Pro	Toll Pro 2	Toll HighSpeed	Toll HighSpeed 2
Special colours	✓	✓	✓	✓	✓
Round boom (MicroBoom-T)	up to 3.0 m	up to 3.0 m	up to 3.0 m	up to 3.0 m	up to 1.5 m
Octagonal boom (MicroBoom-S)	up to 3.5 m	up to 2.5 m	up to 2.5 m	up to 2.5 m	
Soft boom (MicroBoom-AT)	up to 3.0 m	up to 3.0 m	up to 3.0 m	up to 3.0 m	up to 1.5 m
Swing-away flange	all booms	all booms	all booms	all booms	all booms
Auto-swing-away flange	only soft boom	only soft boom	only soft boom	only soft boom	only soft boom
Boom drop contact	✓	✓	✓	✓	✓
Hood light	✓	✓	✓	✓	✓
Key-operated switch	✓	✓	✓	✓	✓
Radio module	✓	✓	✓	✓	✓
Ethernet module	✓	✓	✓	✓	✓
RS485 module	✓	✓	✓	✓	✓
CAN module (counting)	✓	✓	✓	✓	✓
Second detector module	✓	✓	✓	✓	✓
GSM module	✓	✓	✓	✓	✓
Safety light barrier	✓	✓	✓	✓	✓
Battery backup	✓	✓			

Dimensional drawings

Toll with round boom (MicroBoom-T)

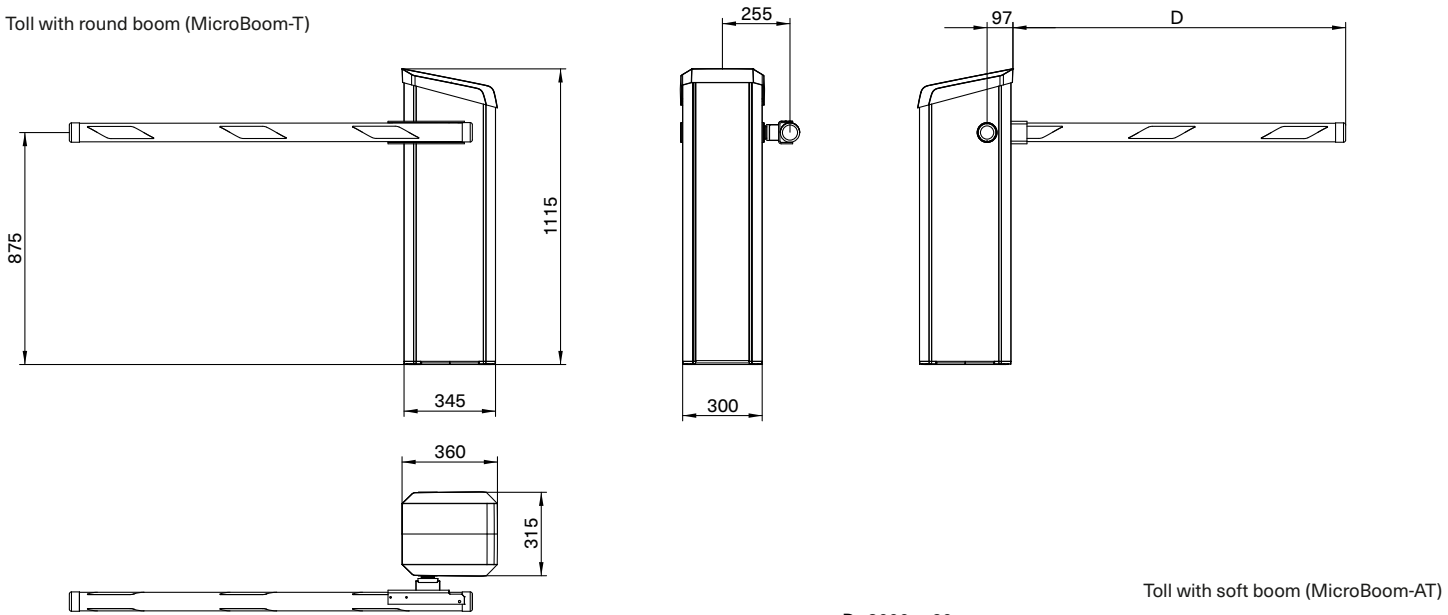

Toll with soft boom (MicroBoom-AT)

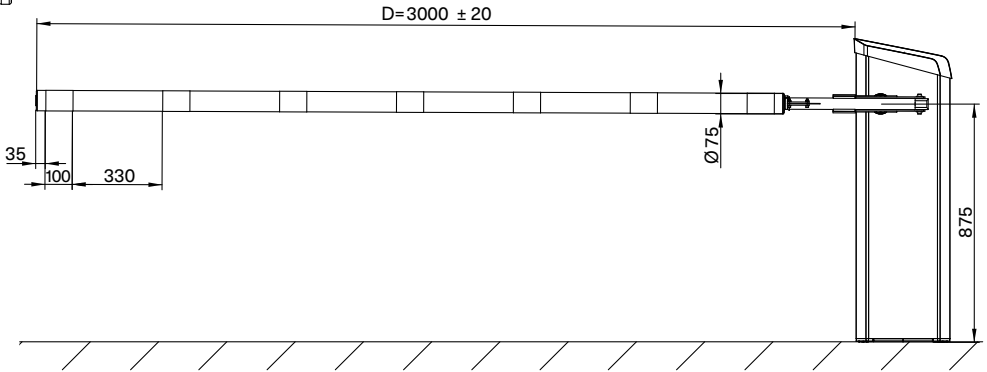

Access to Progress

Magnetic stands for pioneering products – in every way. Our access control systems for vehicles or pedestrians clear the way for thousands of people every day – at car parks, toll gates, stations, airports and in buildings. Our technology is also pioneering, however: with innovative drives, intelligent control systems and well thought-out details it provides maximum safety and longevity. Are you also on the path to Magnetic?



Vehicle barriers

Access barriers
Parking barriers
Toll barriers
Special barriers



Pedestrian gates

Turnstiles
Swing gates
Tripod gates
Retractable gates
Wing gates



Terminals

Cars
Trucks

Germany
MAGNETIC AUTOCONTROL GMBH
Grienmatt 20
79650 Schopfheim
Phone +49 7622 695-5
Fax +49 7622 695-800
E-mail info@magnetic-germany.com

Australia
MAGNETIC AUTOMATION PTY LTD
38 Metrolink Circuit
Campbellfield, VIC 3061
Phone +61 3 9339 2900
E-mail info@magnetic-oz.com

Austria
FAAC GMBH
Münchner Bundesstraße 123
5020 Salzburg
Phone +43 662 853395-0
E-Mail: at.info@faacgroup.com

Benelux countries
FAAC BENELUX NV/SA
Lieven Bauwensstraat 13
8200 Bruges
Belgium
Phone +32 50 451 459
E-mail info@magnetic-benelux.com

Brazil
MAGNETIC AUTOCONTROL LTDA
Av. Salim Antônio Curiati, 136
04690-050 – São Paulo
Phone +55 11 5660 8500
E-mail info@magnetic-br.com

China
MAGNETIC CONTROL SYSTEMS CO., LTD
No. 3 Building, No. 51
Lane 1159, Kang Qiao (East) Road
Kang Qiao Industrial Zone, Shanghai
Phone +86 21 68182970
E-mail info@magnetic-cn.com

France
FAAC FRANCE
377 Rue Ferdinand Perrier
69808 St Priest Cedex
Phone +33 4 72 21 86 89
E-mail info@magnetic-fr.com

India
MAGNETIC AUTOCONTROL PVT LTD.
PRS Centre
Plot No. 373 to 376, 2nd Floor (West Wing)
1st Cross Street, Nehru Nagar
Old Mahabalipuram Road
Kottivakkam (Opp Rayala Technopark, Perungudi)
Chennai 600041
Phone +91 44 421 23297
E-mail info@magnetic-india.com

Middle East
FAAC MIDDLE EAST FZE
Dubai Silicon Oasis
PO Box 54886
Dubai
United Arab Emirates
Phone +971 4 3724193
E-mail info@magnetic-uae.com

N. and S. America (excl. Brazil)
FAAC INTERNATIONAL, INC
3160 Murell Road
Rockledge, FL 32955
USA
Phone +1 321 635 8585
E-mail info@magnetic-usa.com

Scandinavia
FAAC NORDIC AB
Box 125
284 22 Perstorp
Sweden
Phone +46 435 77 95 03
E-mail info@magnetic-nordic.com

Southeast Asia
MAGNETIC CONTROL SYSTEMS SDN. BHD
No. 17, Jalan Anggerik Mokara 31/54
Taman Perindustrian Kota Kemuning
40460 Shah Alam
Selangor Darul Ehsan
Malaysia
Phone +60 3 5123 0033
E-mail info@magnetic-malaysia.com