





**CENTRIFUGAL
FAN COIL UNIT**

VCE



0,51 kW
11,00 kW

0,85 kW
23,75 kW

129 m³/h
2003 m³/h



DESIGN QUALITY COMFORT RELIABILITY 3 VERSION 12 SIZE DESIGN

VCEx0

Installation:
vertical with cabinet
Air intake:
bottom
Air supply:
vertical

version available
with feet



Compact, slim fan coil units. Available in 12 different sizes and 3 versions to satisfy all installation requirements. Wall mounted or floor mounted type with supporting feet, with bottom or front air intake. Horizontal ceiling mounted type, with rear or bottom air intake. Vertical wall recessed type, with top or front air outlet; horizontal ceiling concealed type with front air discharge.

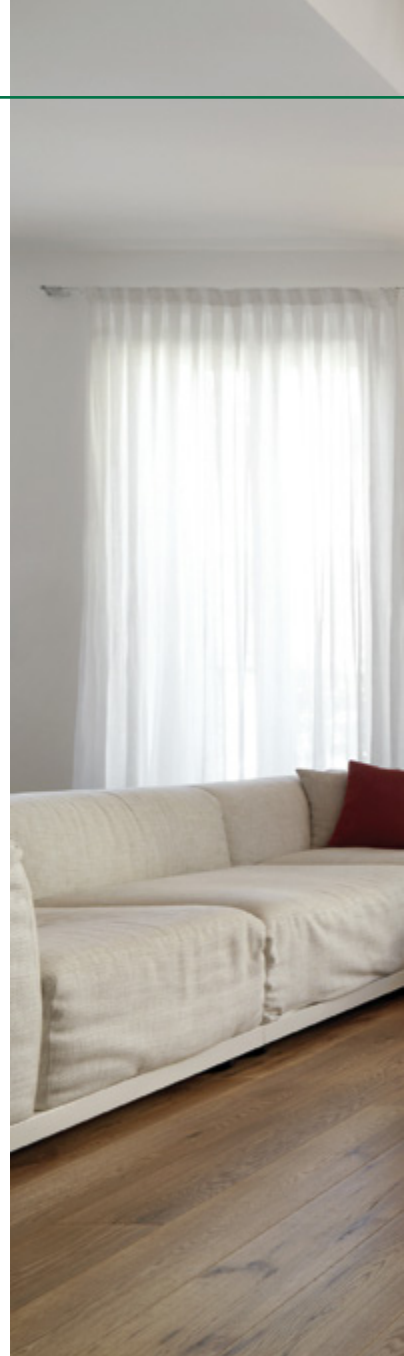

VCEx8

Installation:
vertical with cabinet
Air intake:
bottom
Air supply:
vertical

Unit with air intake socle

VCEx5

Installation:
vertical with cabinet
Air intake:
frontal
Air supply:
vertical

VCEx4

Installation:
horizontal with cabinet
Air intake:
frontal
Air supply:
horizontal

Unit with terminal board

VCEx9

Installation:
horizontal with cabinet
Air intake:
rear
Air supply:
horizontal

Unit with terminal board

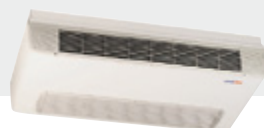



VCEx1

Installation:
horizontal with cabinet
Air intake:
frontal
Air supply:
horizontal

Unit with terminal board
Unit with air intake socle



VCEx7

Installation:
vertical concealed
Air supply:
frontal

Unit with terminal board



VCEx2

Installation:
vertical concealed
Air supply:
frontal

Unit with terminal board



VCEx3

Installation:
horizontal concealed
Air supply:
horizontal

Unit with terminal board



STRUCTURE

Galvanized steel sheet (8/10 mm thick) insulated in all parts in direct contact with the conditioned air. Insulated condensate tray made of galvanized steel sheet, complete with drain plug for complete drainage. Sides with knock-outs for fast fixing of accessories. Wall-anchoring slots for easy fixing and levelling of the unit.

AIR FILTER

Filtering honeycomb polypropylene fabric enclosed within a metal frame to facilitate withdrawal and cleaning.

Filtering rate of the standard model: EU1.

Available with different filtering rate on request.

CONTROL PANEL

The control panel is integrated into the unit's design, covered by a flap. It's fitted as standard on vertical versions and it is equipped with mode selector (off/summer/winter) and speed selector.

On request the unit can come with room thermostat, water low temperature thermostat or control panel with electronic thermostat.

BLOWER SECTION

Double-inlet centrifugal fans with statically and dynamically balanced horizontally-oriented aluminium impellers. Single-phase asynchronous electric motor with overload cutout. 6 speeds of rotation (3 connected).

The motor is directly coupled to the fans and cushioned with flexible mountings to ensure low noise.

eco The unit can be equipped with variable speed EC motor, controlled by a proportional signal 0-10 V.

DECORATIVE CABINET

Modern design that blends in with any environment. Made in hot-dip galvanized steel sheet pre-coated with PVC to ensure high resistance to rust, corrosion, chemical agents, aliphatic solvents and alcohols. Air grilles made of ABS and the control panel protective flap are inserted in the cabinet top.

Standard colour: white. Other RAL colours are available on request.

HEAT EXCHANGER

Coils are made of copper pipe expanded into aluminium fins in continuous block. Brass headers with female fittings (GAS threads) and easily accessible air vents.

In the standard version, the water connections are located on the left (when viewing the outlet). They may be supplied on the right on request.

The unit can be supplied with:

- 2-way valve package;
- 3-way valve package with 4 connections.

ACCESSORIES

A wide range of options and accessories is available for complete requirement satisfaction:

- heating coil for 4 pipe system;
- cooling coil (4 rows or direct expansion);
- temperature control with the 3-way or 2-way valve sets (on/off valves or modulating valves);
- electric heaters;
- external air intake with automatic or manual fresh air louver motor;
- plenum;
- lacquered wooden panel or sheet panel for concealed versions;
- Brushless motors with 0-10 V proportional signal.



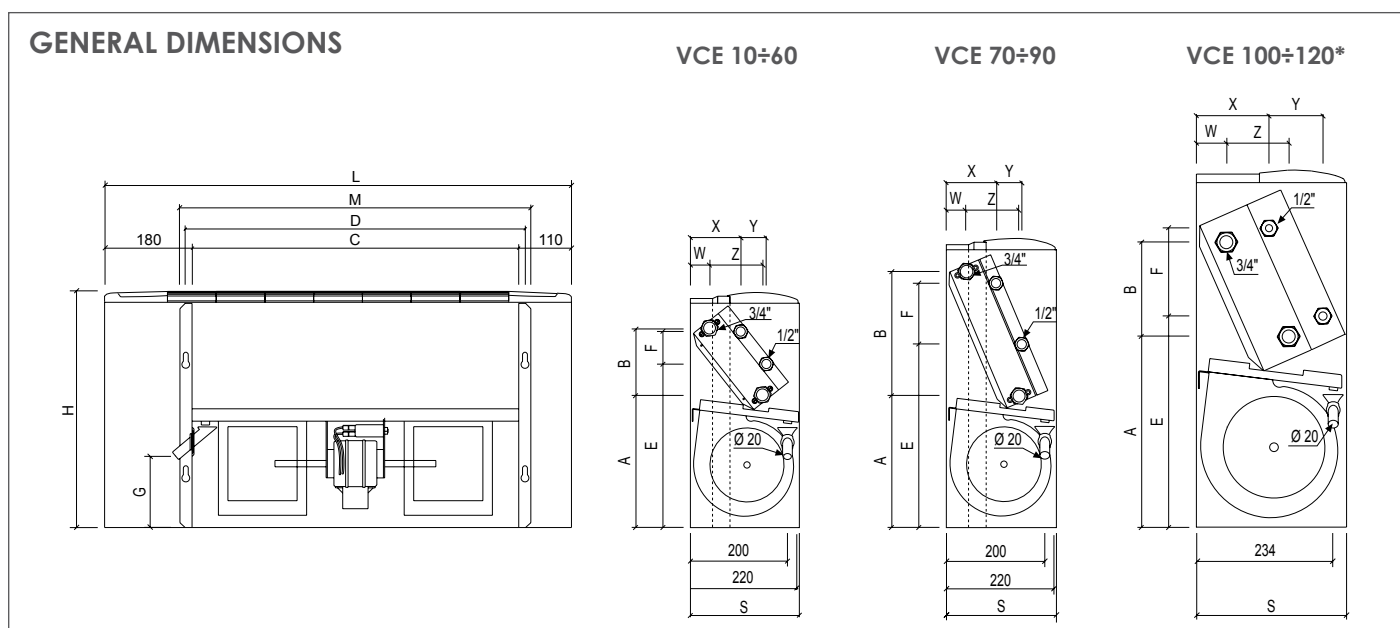

			10	20	30	40	50	60	70	80	90	100	110	120	
Fans		n°	1	1	2	2	2	2	2	2	2	3	3	3	
Standard coil	Rows	n°	3	3	3	3	3	3	3	3	3	3	3	3	
	Fittings	Ø	3/4"	3/4"	3/4"	3/4"	3/4"	3/4"	3/4"	3/4"	3/4"	3/4"	3/4"	3/4"	
Auxiliary coil	Rows	n°	1	1	1	1	1	1	1	1	1	1	1	1	
	Fittings	Ø	1/2"	1/2"	1/2"	1/2"	1/2"	1/2"	1/2"	1/2"	1/2"	1/2"	1/2"	1/2"	
External dimensions	Height	H	mm	480	480	480	480	480	480	585	585	585	602	602	602
	Length	L	mm	660	860	1060	1060	1260	1260	1260	1460	1460	1660	1960	1960
	Depth	S	mm	220	220	220	220	220	220	220	220	220	256	256	256
Internal dimensions	M	mm	420	620	820	820	1020	1020	1020	1220	1220	1380	1680	1680	
	C	mm	370	570	770	770	970	970	970	1170	1170	1330	1630	1630	
	D	mm	395	595	795	795	995	995	995	1195	1195	1356	1656	1656	
Standard coil hydraulic connections	A	mm	274	274	274	274	274	274	268	268	268	333	333	333	
	B	mm	137	137	137	137	137	137	253	253	253	173	173	173	
	W	mm	39	39	39	39	39	39	41	41	41	39	39	39	
	Z	mm	109	109	109	109	109	109	107	107	107	141	141	141	
Auxiliary coil hydraulic connections	E	mm	337	337	337	337	337	337	374	374	374	395	395	395	
	F	mm	67	67	67	67	67	67	124	124	124	120	120	120	
	X	mm	103	103	103	103	103	103	101	101	101	115	115	115	
	Y	mm	53	53	53	53	53	53	52	52	52	62	62	62	
Condensate drain fittings	G	mm	147	147	147	147	147	147	147	147	147	167	167	167	
Net weight		kg	14	17	22	23	27	28	30	35	36	46	55	57	



* Note: dimensions for models 100-120 referred to units with left side water connection

	10	20	30	40	50	60	70	80	90	100	110	120
--	----	----	----	----	----	----	----	----	----	-----	-----	-----

2 pipe system (3R coil)

	Total cooling capacity	(E) W max	860	1280	2170	2390	3110	3530	4100	5590	6900	7970	10000	11000
		(E) W med	790	1170	1940	1920	2790	3130	3510	5170	5960	6830	7690	9380
		(E) W min	670	1080	1450	1450	2200	2500	3080	4480	4830	6240	6020	6910
	Sensible cooling capacity	(E) W max	740	1020	1760	1940	2180	2820	3150	3960	4820	6060	7910	8470
		(E) W med	650	900	1570	1530	1930	2450	2670	3620	4110	5120	5920	7120
		(E) W min	510	810	1200	1170	1500	1940	2300	3130	3290	4620	4580	5110
Water flow		l/h max	148	219	372	433	534	606	694	959	1185	1367	1716	1888
Water pressure drop		(E) kPa max	0,9	2	6,3	8,8	16,1	25,9	37,6	27,9	19,1	26,6	21,5	26
	Heating capacity	(E) W max	1250	1870	2590	3280	3660	4480	5140	6690	8130	10100	13100	13300
		(E) W med	1100	1650	2330	2640	3270	3940	4370	6180	6980	8540	9930	11200
		(E) W min	850	1470	1870	2110	2600	3120	3800	5360	5620	7770	7750	8150
Water flow		l/h max	148	219	372	433	534	606	694	959	1185	1367	1716	1888
Water pressure drop		(E) kPa max	0,7	1,4	4,9	7,5	13,7	22	34,7	23,7	17,6	23,3	18,8	24,2
Air flow	m³/h max	227	288	403	451	576	685	708	1057	1242	1354	2012	2003	
	m³/h med	189	244	352	344	495	579	577	950	1014	1040	1371	1510	
	m³/h min	136	209	270	263	360	429	489	786	769	969	987	1055	
Sound power level	(E) db(A) max	46	45	44	47	47	52	52	60	64	63	67	66	
	(E) db(A) med	41	41	41	40	43	47	46	56	58	57	58	61	
	(E) db(A) min	33	39	34	33	37	38	42	51	51	55	50	53	
Sound pressure level	db(A) max	37	36	35	38	38	43	43	51	55	54	58	57	
	db(A) med	32	32	32	31	34	38	37	47	49	48	49	52	
	db(A) min	24	30	25	24	28	29	33	42	42	46	41	44	
Power input	(E) W max	30	32	43	50	59	80	76	150	187	185	265	265	
	(E) W max	23	27	36	35	48	59	59	130	150	140	215	230	
	(E) W max	16	22	26	26	33	40	50	115	115	127	160	160	
Absorbed current		A max	0,18	0,25	0,28	0,28	0,45	0,45	0,44	0,96	0,95	0,97	1,27	1,25
Water content		L -	0,59	0,93	1,27	1,27	1,61	1,61	2,42	2,93	2,93	3,28	4,04	4,04

- **Standard unit with free outlet:** external static pressure = 0 Pa
- **Sound power level:** ISO 23741
- **Sound pressure level:** 8,6 dB(A) lower that the sound power level for a room of 90 m³ with a reverberation time of 0,5 sec.
- **Supported power supply:** ~230V±10% / 1ph / 50-60Hz



COOLING
Inlet water temp.: 7°C
Outlet water temp.: 12°C
Inlet air temp.: 27°C d.b., - 19°C w.b.



HEATING
Air temp.: 20°C
Inlet water temp.: 50°C



HEATING
Air temp.: 20°C
Inlet water temp.: 70/60°C

(E)



				10	20	30	40	50	60	70	80	90	100	110	120
4 pipe system (3R+1R coil)															
Total cooling capacity	(E)	W	max	840	1230	2080	2380	2760	3690	4470	5350	6570	7710	9700	10700
	(E)	W	med	770	1130	1850	1900	2480	3260	3830	4950	5660	6590	7430	9060
	(E)	W	min	650	1040	1380	1440	1960	2610	3350	4280	4580	6050	5790	6650
Sensible cooling capacity	(E)	W	max	710	1120	1600	1930	2220	2910	3340	4110	5260	5860	7660	8200
	(E)	W	med	630	990	1430	1520	1960	2540	2830	3760	4470	4940	5720	6890
	(E)	W	min	500	890	1090	1160	1530	2000	2440	3260	3570	4470	4400	4920
Water flow		l/h	max	144	211	357	407	473	633	771	917	1128	1322	1663	1834
Water pressure drop	(E)	kPa	max	0,61	2	5,7	8,2	10,7	20	49,8	11,6	17	24,9	21,7	25,1
Heating capacity	(E)	W	max	1260	1890	2730	2890	3490	4140	5040	6210	7670	8380	10100	11400
	(E)	W	med	1110	1670	2450	2330	3120	3750	4290	5840	6580	7390	8160	10000
	(E)	W	min	860	1490	1970	1860	2450	3150	3710	5240	5300	6900	6750	9410
Water flow		l/h	max	111	166	239	253	306	363	442	545	673	735	886	1000
Water pressure drop	(E)	kPa	max	2,1	5,7	13,9	16,4	27,9	35,1	61,5	22	30	48,4	41,3	58,5
Air flow		m³/h	max	216	274	383	428	545	650	672	1003	1179	1289	1913	1905
		m³/h	med	180	231	333	326	469	548	549	901	962	1039	1304	1513
		m³/h	min	128	200	256	249	343	407	463	749	731	923	941	1004
Sound power level	(E)	db(A)	max	45	47	44	47	46	53	53	59	65	63	67	67
	(E)	db(A)	med	40	43	40	41	42	48	47	57	59	58	58	62
	(E)	db(A)	min	34	39	34	35	35	41	43	51	51	55	51	52
Sound pressure level		db(A)	max	36	38	35	38	37	44	44	50	56	54	58	58
		db(A)	med	31	34	31	32	33	39	38	48	50	49	49	53
		db(A)	min	25	30	25	26	26	32	34	42	42	46	42	43
Power input	(E)	W	max	30	32	43	50	59	80	76	150	187	185	265	265
	(E)	W	med	23	27	36	35	48	59	59	130	150	140	215	230
	(E)	W	min	16	22	26	26	33	40	50	115	115	127	160	160
Absorbed current		A	max	0,18	0,25	0,28	0,28	0,45	0,45	0,44	0,96	0,95	0,97	1,27	1,25
Water content (3R coil)		L	-	0,59	0,93	1,27	1,27	1,61	1,61	2,42	2,93	2,93	3,28	4,04	4,04
Water content (1R coil)		L	-	0,19	0,31	0,42	0,42	0,53	0,53	0,53	1,29	1,29	1,09	1,35	1,35

- **Standard unit with free outlet:** external static pressure = 0 Pa
- **Sound power level:** ISO 23741
- **Sound pressure level:** 8,6 dB(A) lower that the sound power level for a room of 90 m³ with a reverberation time of 0,5 sec.
- **Supported power supply:** ~230V±10% / 1ph / 50-60Hz



COOLING
 Inlet water temp.: 7°C
 Outlet water temp.: 12°C
 Inlet air temp.: 27°C d.b., - 19°C w.b.



HEATING
 Air temp.: 20°C
 Inlet water temp.: 50°C



HEATING
 Air temp.: 20°C
 Inlet water temp.: 70/60°C

(E)



ECM: NEW SOLUTION

New range of fan motors for fan coil application, with a very low power input.

These type of motors, designed according to the latest technology and combined with a proper electronic control of stop and go status, allow an energy saving of a 50% compared to a standard motor.

Consequently, we can forecast a CO₂ emission which is 40/50% less than the one caused by a standard PSC motor whose speeds are given by a transformer and/or given by the winding.

GENERAL FEATURES

ECM motors are completely interchangeable with those of the already well known motors. Mechanical structure and cradles are in fact the same and the only difference is having replaced the transformer with the electronic control case.

Moreover, these motors have been designed to give a performance similar to the standard ones, but with the possibility of being used with a 0-10V control.

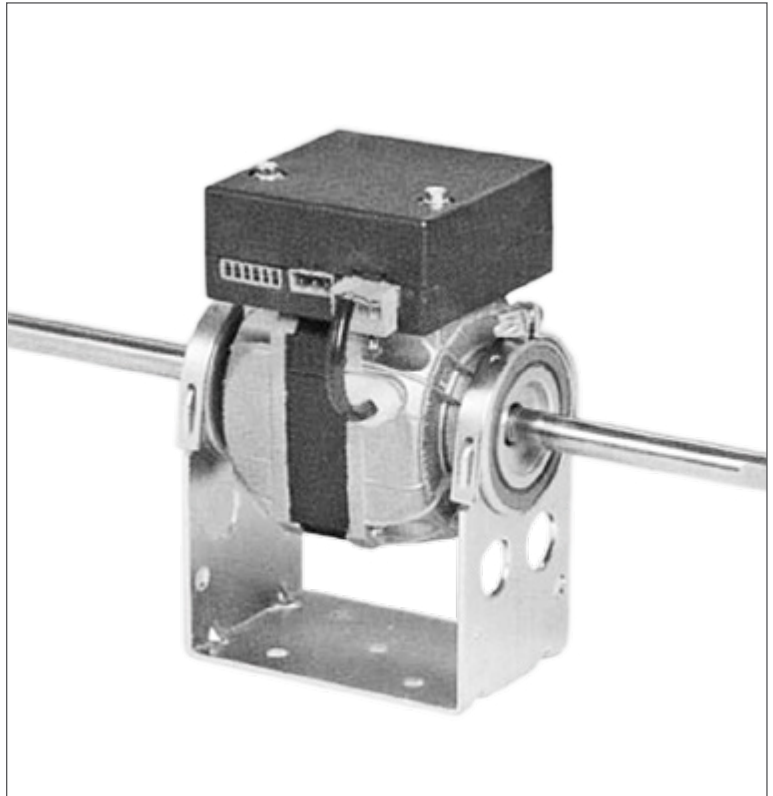

TRY THE FUTURE

By this type of fan motors, the users can be personalise the speeds according to their request, by means of any control which can easily be designed.

This opens a new perspective to room air conditioning. In fact the fan coil manufacturer can program valves, motors and clutches by means of the same logic, with the result that the final user can get an optimised system of room conditioning with a low CO₂ impact.

By using these type of motors, it is possible to satisfy the requirements of the "ecodesign" prescriptions suggested by Eurovent and is also in line with the future requirements, given a lower input power demand.

WORK ECM MOTORS

The basic explanation of a ECM motor's construction is that it is similar to a brushed motor, except everything is 'inside out' and there are no brushes at all. The permanent magnets that would wrap around the armature in a normal motor are instead placed around the motor shaft, and this assembly is called the rotor. The wire coils are around the inside of the motor can, making several different magnetic poles. In a sensored ECM motor, there are sensors on the rotor that send signals back to the electronic speed control.

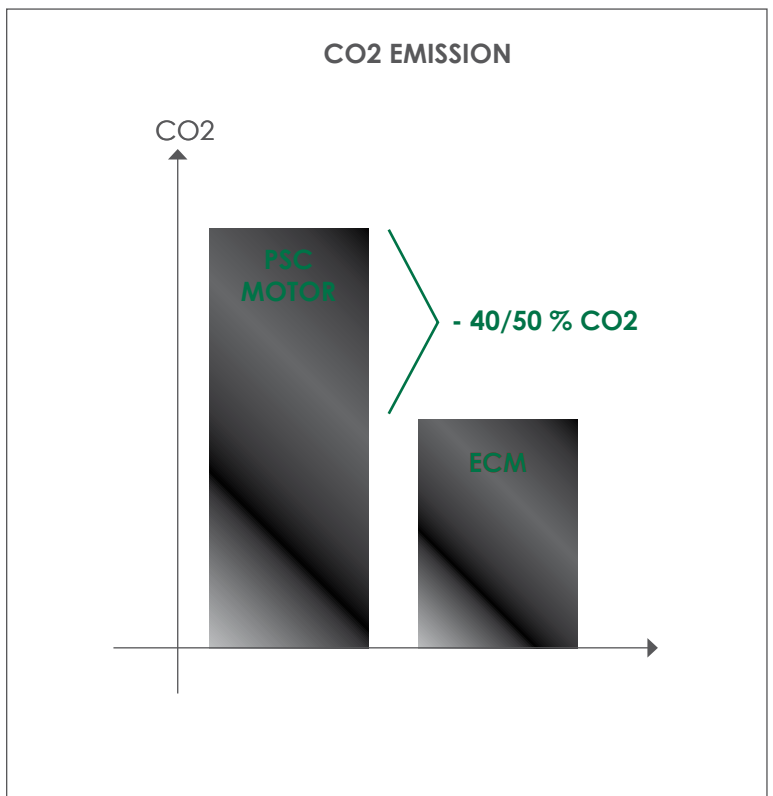

Air flow (Fans 2x146x196)

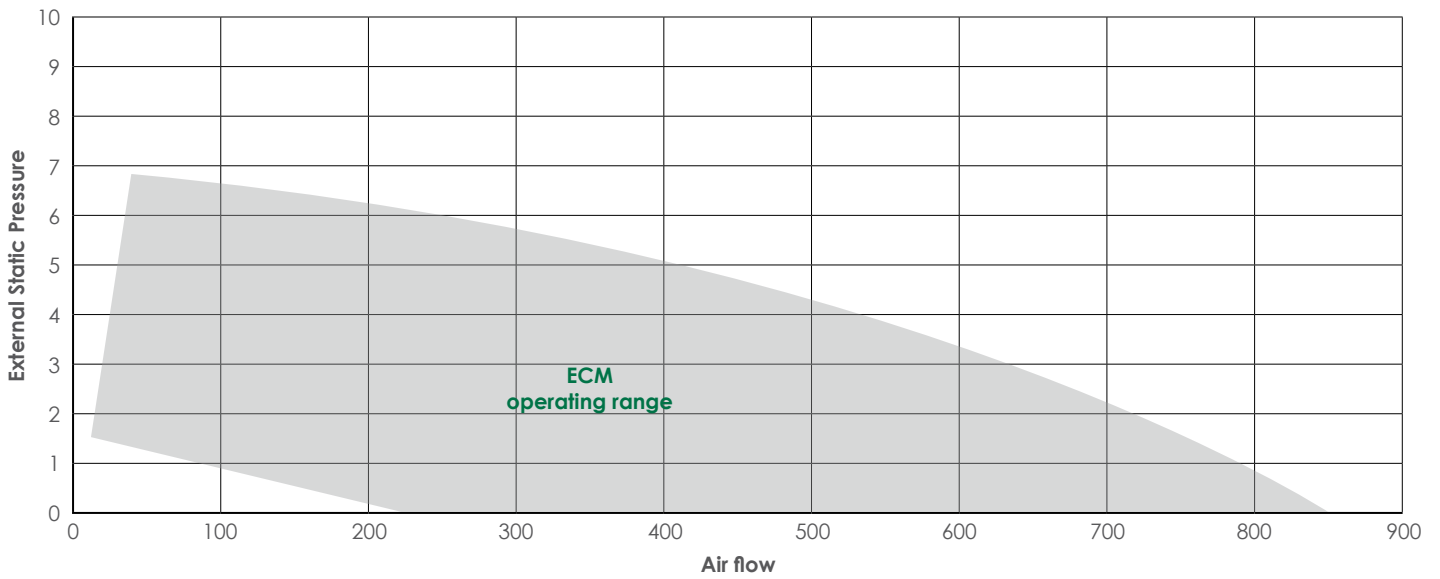

Energy Saved by ECM

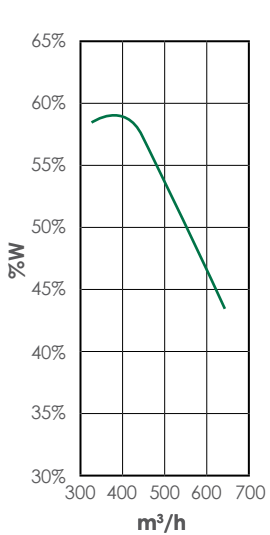

Absorbed power

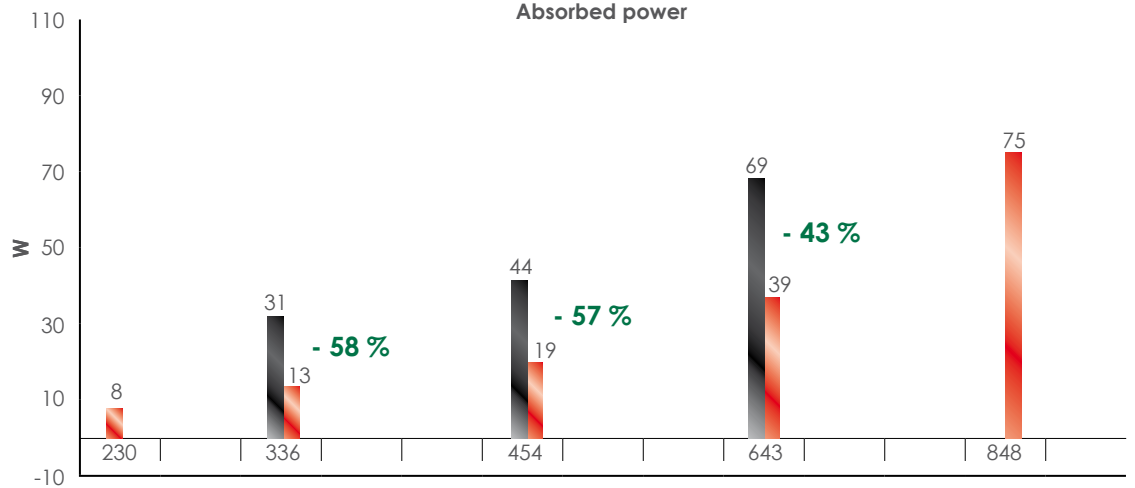

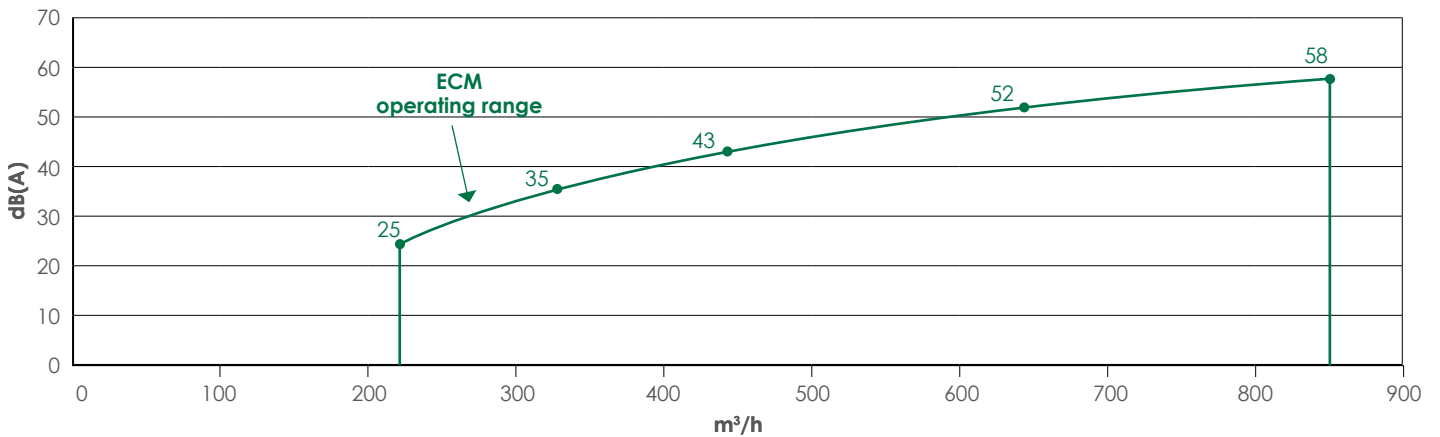

Noisiness



ECM MOTORS	20	40	60	70	90	100	120
------------	----	----	----	----	----	-----	-----

2 pipe system (3R coil)

 Total cooling capacity	W	max	1280	2390	3530	4100	6900	7970	11000
	W	med	1170	1920	3130	3510	5960	6830	9380
	W	min	1080	1450	2500	3080	4830	6240	6910
 Sensible cooling capacity	W	max	1020	1940	2820	3150	4820	6060	8470
	W	med	900	1530	2450	2670	4110	5120	7120
	W	min	810	1170	1940	2300	3290	4620	5110
Water flow	l/h	max	220	433	606	693	1184	1366	1888
Water pressure drop	kPa	max	2	8,8	25,9	37,6	19,1	26,6	26
 Heating capacity	W	max	1870	3280	4480	5140	8130	10100	13300
	W	med	1650	2640	3940	4370	6980	8540	11200
	W	min	1470	2110	3120	3800	5620	7770	8150
Water flow	l/h	max	220	433	606	693	1184	1366	1888
Water pressure drop	kPa	max	1,4	7,5	22	34,7	17,6	23,3	24,2
Air flow	m³/h	max	288	450	685	708	1242	1354	2003
	m³/h	med	243	344	578	578	1014	1040	1510
	m³/h	min	210	263	429	489	769	969	1055
Sound power level	db(A)	max	45	47	52	52	64	63	66
	db(A)	med	41	40	47	46	58	57	61
	db(A)	min	37	33	38	42	51	55	53
Sound pressure level	db(A)	max	36	38	43	43	55	54	57
	db(A)	med	32	31	38	37	49	48	52
	db(A)	min	28	24	29	33	42	46	44
Power input	W	max	12,5	17	32	42	146	64	200
	W	med	9,5	11	20	23	66	43	116
	W	min	8	7	10	16,5	25	33	36
Input control voltage	V	-	2.5/3.4/4.5	3/4.5/6.4	3.2/5/6.6	4.7/5.8/7.6	4.4/6.8/9.6	4.2/4.7/6	3.5/6/7.5

- **Standard unit with free outlet:** external static pressure = 0 Pa
- **Sound power level:** ISO 23741
- **Sound pressure level:** 8,6 dB(A) lower than the sound power level for a room of 90 m³ with a reverberation time of 0,5 sec.
- **Supported power supply:** ~230V±10% / 1ph / 50-60Hz



COOLING
 Inlet water temp.: 7°C
 Outlet water temp.: 12°C
 Inlet air temp.: 27°C d.b. - 19°C w.b.



HEATING
 Air temp.: 20°C
 Inlet water temp.: 50°C



HEATING
 Air temp.: 20°C
 Inlet water temp.: 70/60°C

ECM MOTORS	20	40	60	70	90	100	120
------------	----	----	----	----	----	-----	-----

4 pipe system (3R+1R coil)

	Total cooling capacity	W	max	1230	2380	3690	4470	6570	7710	10700
		W	med	1130	1900	3260	3830	5660	6590	9060
		W	min	1040	1440	2610	3350	4580	6050	6650
	Sensible cooling capacity	W	max	1120	1930	2910	3340	5260	5860	8200
		W	med	990	1520	2540	2830	4470	4940	6890
		W	min	890	1160	2000	2440	3570	4470	4920
	Water flow	l/h	max	211	407	633	771	1128	1322	1834
	Water pressure drop	kPa	max	2	8,2	20	49,8	17	24,9	25,1
	Heating capacity	W	max	1890	2890	4140	5040	7670	8380	11400
		W	med	1670	2330	3750	4290	6580	7390	10000
		W	min	1490	1860	3150	3710	5300	6900	9410
	Water flow	l/h	max	166	253	364	442	673	735	1000
	Water pressure drop	kPa	max	5,7	16,4	35,1	61,5	30	48,4	47,3
	Air flow	m ³ /h	max	274	428	650	672	1179	1289	1905
		m ³ /h	med	231	326	548	549	962	1039	1513
		m ³ /h	min	199	248	407	462	731	923	1004
	Sound power level	db(A)	max	47	47	53	53	65	63	67
		db(A)	med	43	41	48	47	59	58	62
		db(A)	min	39	35	41	43	51	55	52
	Sound pressure level	db(A)	max	38	38	44	44	56	54	58
		db(A)	med	34	32	39	38	50	49	53
		db(A)	min	30	26	32	34	42	46	43
	Power input	W	max	12,5	17	32	42	146	64	200
		W	med	9,5	11	20	23	66	43	116
		W	min	8	7	10	16,5	25	33	36
	Input control voltage	V	-	2.5/3.4/4.5	3/4.5/6.4	3.2/5/6.6	4.7/5.8/7.6	4.4/6.8/9.6	4.2/4.7/6	3.5/6/7.5

- **Standard unit with free outlet:** external static pressure = 0 Pa
- **Sound power level:** ISO 23741
- **Sound pressure level:** 8,6 dB(A) lower than the sound power level for a room of 90 m³ with a reverberation time of 0,5 sec.
- **Supported power supply:** ~230V±10% / 1ph / 50-60Hz



COOLING
 Inlet water temp.: 7°C
 Outlet water temp.: 12°C
 Inlet air temp.: 27°C d.b. - 19°C w.b.



HEATING
 Air temp.: 20°C
 Inlet water temp.: 50°C



HEATING
 Air temp.: 20°C
 Inlet water temp.: 70/60°C



**A GROUP TAKES PART TO THE EUROVENT PROGRAM
OF FAN COIL PERFORMANCE CERTIFICATION
IN ORDER TO PROVIDE ITS CUSTOMERS THE RELIABILITY
AND ACCURACY OF PERFORMANCES.**

