

LIGHT LIGHT-ECM

CASSETTE FAN COIL UNIT

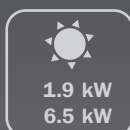

MEKAR[®]
AIR HANDLING UNITS

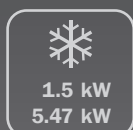
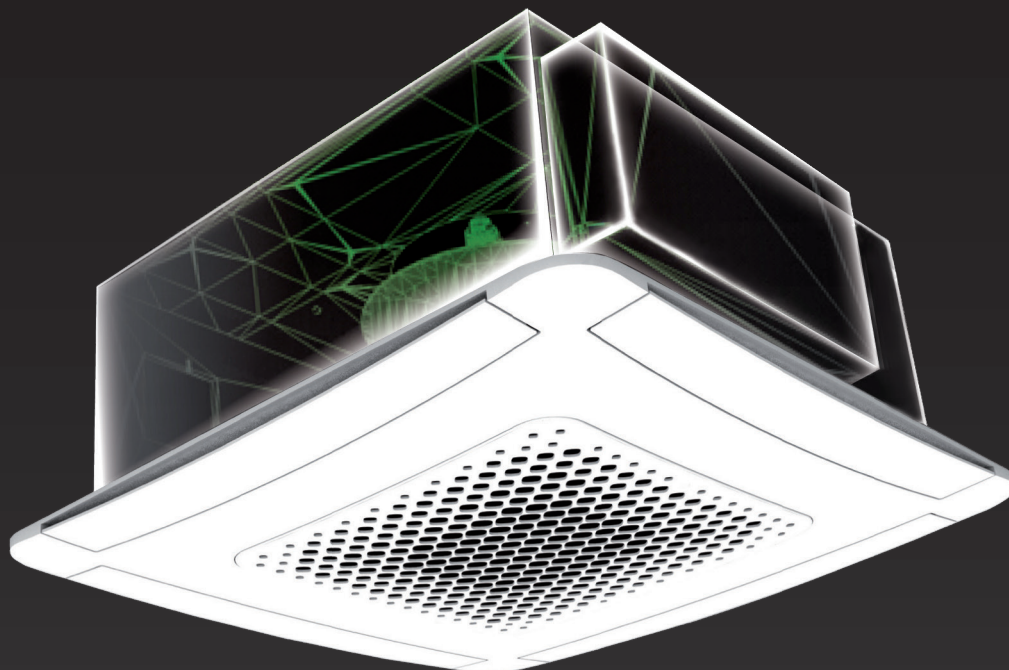

WATCH THE VIDEO

AUTOMATIC
LOUVERS

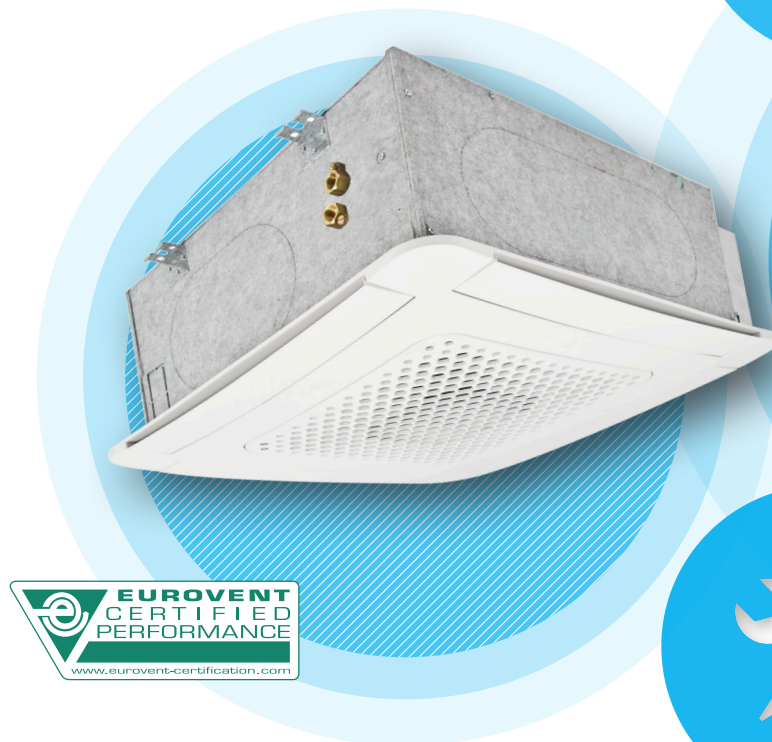

NEW
LIGHT
WATERCASSE
600x600



EASY INSTALLATION
AND MAINTENANCE

LIGHT, the new cassette fan coil unit

LIGHT is the new cassette fan coil unit characterised by innovative design and a perfect blend of performance, low sound emission and extreme ease of installation and maintenance.

The unit is produced in modular dimensions of 600 x 600mm and is available in 5 different capacities for the 2 pipe versions (61-62-63-64-65), and in 6 capacities for the 4 pipe versions (81-82-83-83C-84-84C).

The models 83 and 84 are designed mainly for heating, whereas the plus 83C and 84C versions are more for cooling. The unit is equipped with a wide range of controls, like the infrared remote control or the BMS connection, that offer multiple adjustment solutions.

The front panel made from pure white ABS is available in manually or automated adjustable air distribution louvers version, equipped with 4 independent small step by step type motors. Multiple combinations of integrated valves and integrated sheathed electric heaters, from 1500 to 2500W, offer great flexibility of personalisation of the unit during the production phase.

LIGHT-ECM series is equipped with an innovative EC Brushless synchronous motor that ensures exceptional energy consumption reductions up to 78%.

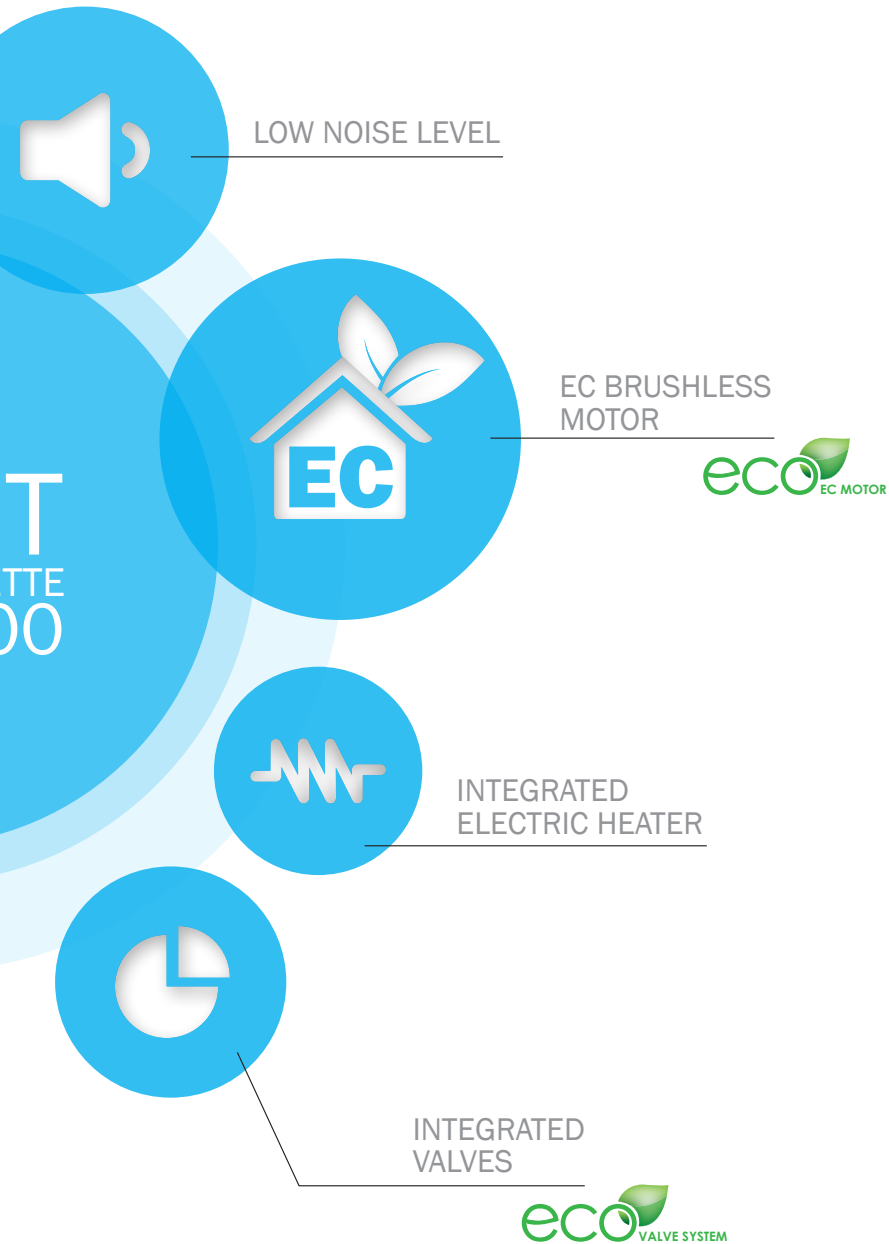

❄️ **1.5 - 5.5**
kW - cooling

☀️ **1.9 - 6.5**
kW - heating

🏠 **-78%** (up to)
low consumption

✂️ **224 - 760**
m³/h

⚡ **1,5 - 2,5**
kW



EC Brushless Motor

It allows accurate and precise regulation of the fan by limiting the power of the effective work load, without any useless waste.



Automatic louvers

For a in perfect control of the climatic comfort in cooling and heating modalities.



Low noise level

For a 360° room comfort that ensures that particular condition of physical and psychological well-being of the individual.



Integrated valves

It helps to avoid unnecessary energy thermal dispersion in case the unit is turned off.



Integrated electric heater

It allows an efficient decrease in installation delay and guarantees functional reliability.



Easy installation and maintenance

Thanks to **EasyWaySystem**, who allowing access to all the main components in need of ordinary or extraordinary maintenance.

LIGHT, a **comfort** solution

The design of the front panel made from pure white ABS is an excellent compromise of style, efficiency and functionality. Its particular geometry and the positioning of the air distribution louvers on the perimeter combine to control the air flow precisely and directly, offering the possibility to set up the best kind of diffusion, whether automatic or manual, based on the climatic requirements resulting in perfect control of the climatic comfort in cooling and heating modalities.

Coanda Effect

The position of the lateral air distribution louvers allows maximum exploitation of the Coanda effect in summer modality, offering ideal comfort without any annoying typical cold air flow. Thanks to this detail the cold air tends to flow towards the ceiling distributing itself in a regular, gradual way inside the room, guaranteeing ideal climatic comfort without the unpleasant thermal phenomena caused by direct cold air.

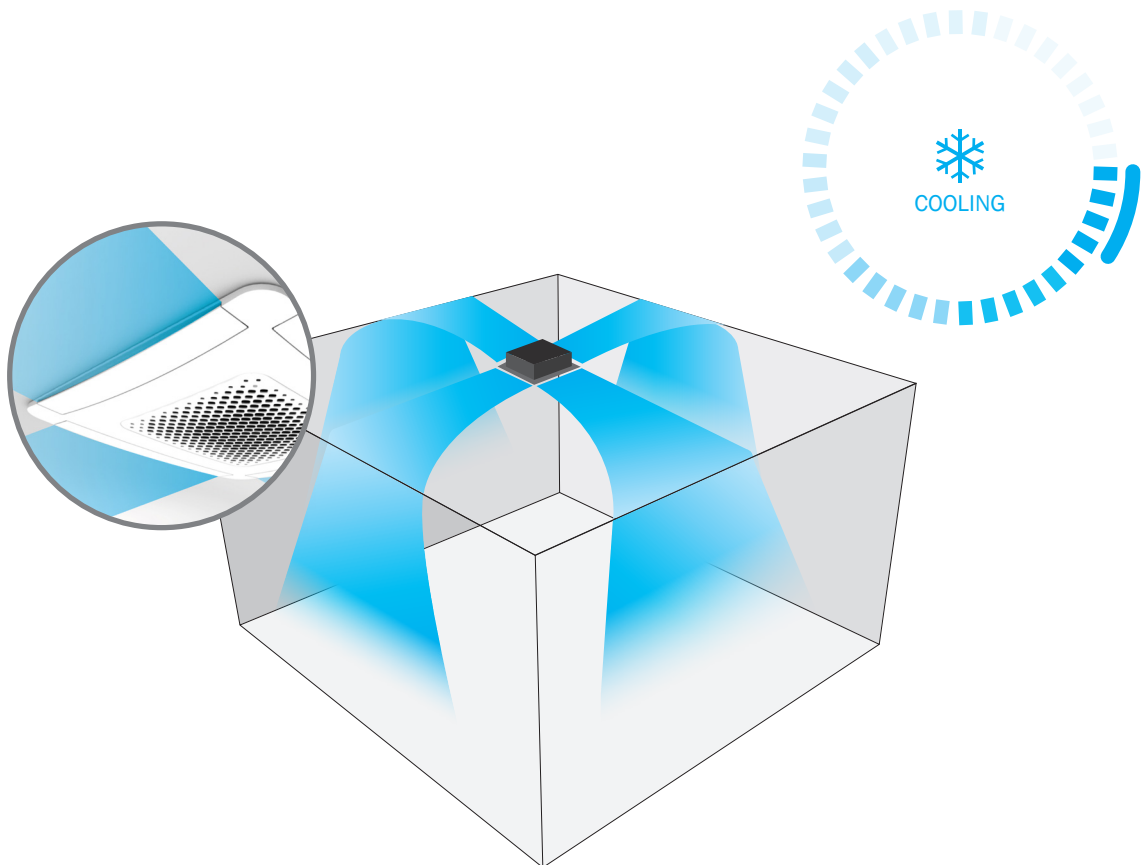

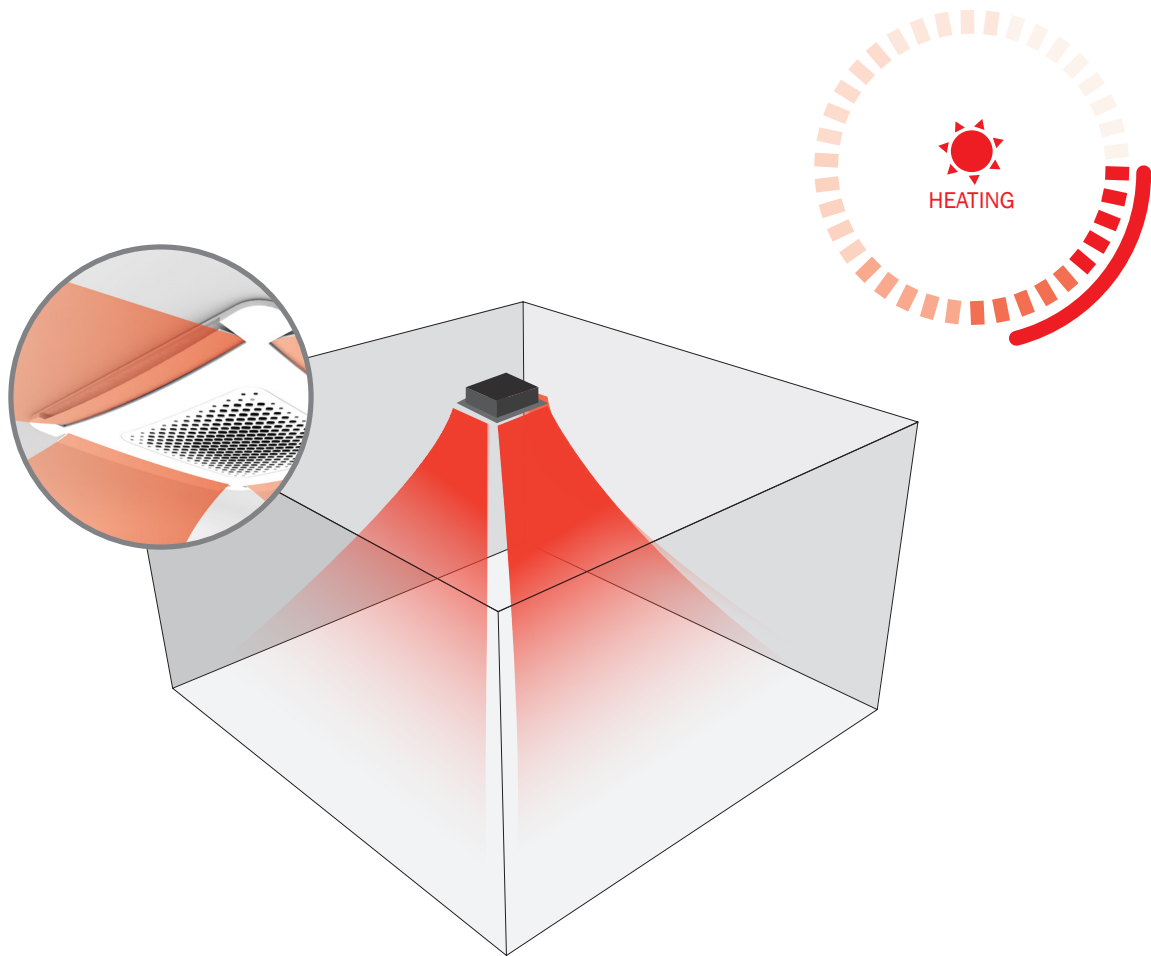

Anti stratification effect

In heating modality, the air distribution louvers are positioned automatically (optional) with an opening of 35°, allowing the warm air to create a downward airflow, ensuring the homogenous distribution of the room temperature and avoiding the problems linked to air stratification.



LIGHT and details

Front panel LIGHT is an innovative cassette fan coil unit, the result of accurate planning and design research to optimise the functional performance of the unit and guarantee optimal comfort and an aesthetically pleasing product.

The extremely thin front panel made of glaze pure white RAL9010 ABS, with its modern and minimalist design, can integrate perfectly with any kind of installation, residential or commercial, such as offices, stores and public places in general.

The LIGHT cassette panel follows the 600x600mm modular design for perfect integration with the standard dimensions that are common in false ceilings.

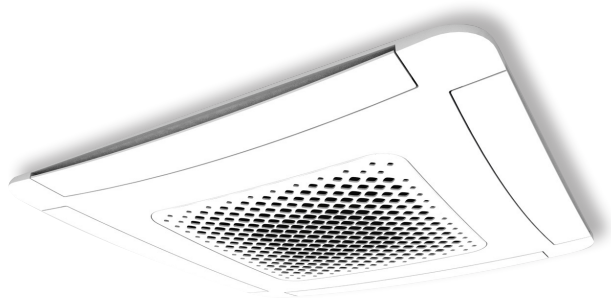

Acoustic comfort Defending the source of noise was a primary and binding requirement ever since the planning phase. Noise provokes psychological disturbance and hinders the development of normal human activities, reducing human performance and ability to concentrate. Aware of the importance of acoustic as well as climatic comfort in rooms, the innovative LIGHT cassette fan coil unit has reached a perfect blend between performance and low sound emissions thanks to precise research and intense lab activity. This result was rendered possible thanks to the particular geometry that distinguishes the front panel, capable of optimising the outwards air flow and eliminating any type of turbulence and resistance that are the principal noise sources. The result is 360° room comfort that ensures that particular condition of physical and psychological well-being of the individual, ensuring maximum respect for the activities being carried out.



Integrated valve kit LIGHT was planned with the objective of being capable of integrating the valves module (optional), therefore guaranteeing functional reliability and cost reduction during the installation phase by the installing Company. The valves will be assembled and lodged inside the chassis directly during the production phase, therefore supplying the unit ready for installation.

The presence of the valves represents the guarantee of energy savings with the water by-pass that helps to avoid useless unnecessary thermal dispersion in case the unit is turned off, avoiding condensation on the frame.



Integrated electric heater The new LIGHT cassette is also available with sheathed electric heaters directly integrated inside the coil pipes.

This type guarantees optimal performance and, being installed by the company during the production phase, it allows an efficient decrease in installation delay and guarantees functional reliability.





EasyWaySystem

Maintenance operations can be even simpler and faster thanks to the *EasyWaySystem* above all when unit is installed in modular false ceilings, allowing an excellent accessibility to all the main components in need of ordinary or extraordinary maintenance, thanks to an easily removed side panel that allows to avoid the typical procedure to remove grill, filter and main drain pan. Once the side panel is removed the main components such as the valves, condensate drain pump, float, main drain pan and all the electric cabling can be easily accessed. The *EasyWaySystem* system guarantees the possibility to work on the unit from the side rather than from below, with remarkable advantages for the maintenance operator.



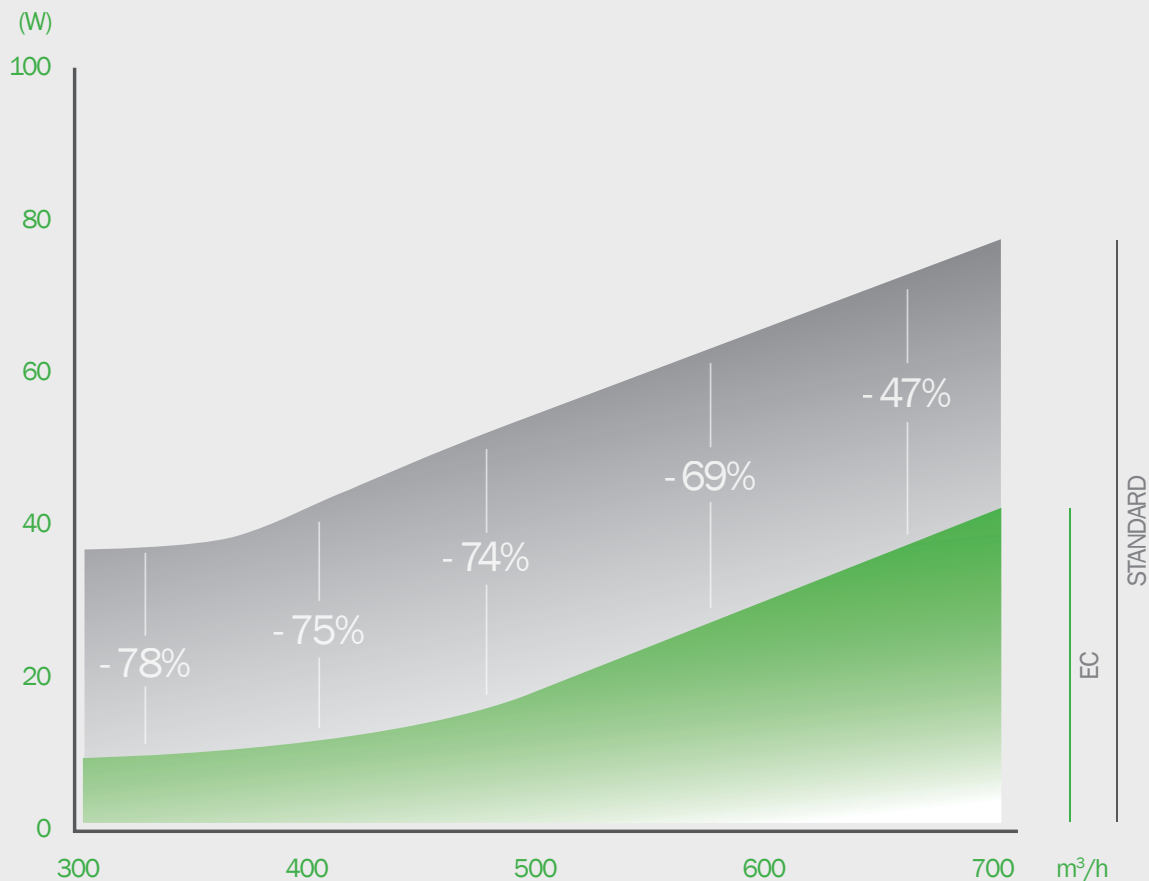

LIGHT-ECM,

saving while respecting the environment

-78%

LIGHT-ECM series is equipped with an innovative EC Brushless synchronous motor controlled by an inverter installed on board, that allows accurate and precise regulation of the fans by limiting the power of the effective work load, without any useless waste.

Compared to a unit with a traditional asynchronous motor, the LIGHT-ECM series ensures an exceptional decrease up to 78% in energy consumption, even when it is functioning at low speed.

The EC motor version allows remarkable economic savings and relative decrease of CO2 emissions in the atmosphere, it is also capable of improving room comfort considerably with constant air capacity variations, immediate and precise attainment of the thermal level required by the user and maintaining it all day long and finally by offering a better acoustic comfort, which is guaranteed by its low speed.

LIGHT / LIGHT-ECM	61	62	63	64	65	81	82	83	83C	84	84C
-------------------	----	----	----	----	----	----	----	----	-----	----	-----

TECHNICAL DATA			2 PIPE					4 PIPE					
Coil fittings	main	∅	1/2"	1/2"	3/4"	3/4"	3/4"	1/2"	1/2"	1/2"	1/2"	1/2"	1/2"
	auxiliary	∅	-	-	-	-	-	1/2"	1/2"	1/2"	1/2"	1/2"	1/2"
Condensate drain fitting		∅ mm	13,5										

UNIT WEIGHT													
Unit	kg	20	21	23	23	24	23	24	24	24	24	24	24
Front panel	kg	3											

PACKED UNIT DIMENSIONS													
Unit	mm	650 x 720 x H340											
Front panel	mm	740 x 740 x H120											

PACKED UNIT WEIGHTS													
Unit	kg	22	23	25	25	26	25	26	26	26	26	26	26
Front panel	kg	4											

WATER CASSETTE DIMENSIONS (mm)
(with auxiliary drain pan)

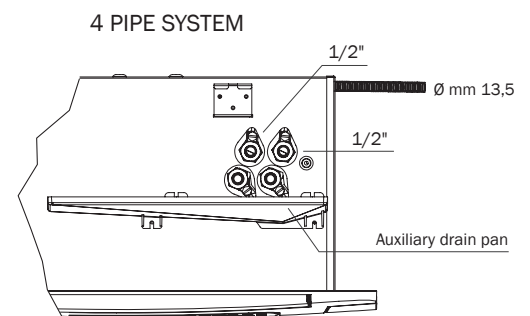
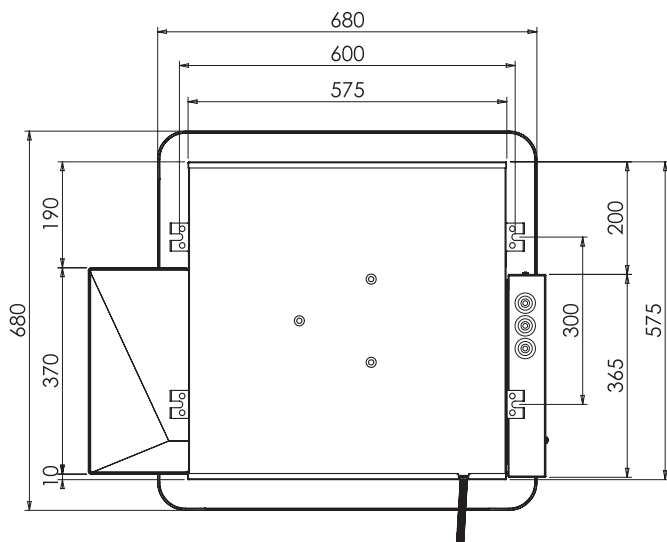
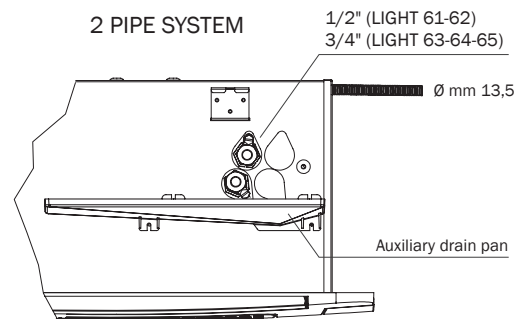
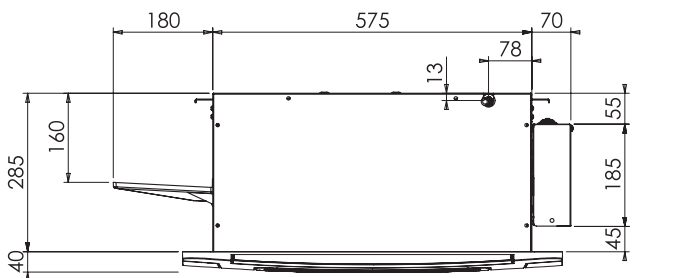

LIGHT / LIGHT-ECM				61	62	63	64	65
-------------------	--	--	--	----	----	----	----	----

2-PIPE SYSTEM

	Total cooling capacity	(E)	W	max	2270	2710	4310	5050	5470
		(E)	W	med	1870	2470	3090	3700	4730
		(E)	W	min	1580	1970	2170	2730	4030
	Sensible cooling capacity	(E)	W	max	1890	2070	3170	3770	4080
		(E)	W	med	1520	1850	2220	2680	3430
		(E)	W	min	1260	1450	1520	1940	2860
	Water flow		l/h	max	391	467	742	869	941
			l/h	med	322	425	532	637	814
			l/h	min	272	339	374	470	694
Water pressure drop	(E)	kPa	max	20	16	24	24	30	
	(E)	kPa	med	14	14	18	18	24	
	(E)	kPa	min	11	10	11	16	18	
	Heating capacity	(E)	W	max	2800	3150	4910	5900	6500
		(E)	W	med	2300	2850	3522	4150	5900
		(E)	W	min	1900	2300	2510	3100	4900
Water pressure drop	(E)	kPa	max	19	16	19	21	29	
	(E)	kPa	med	13	13	17	18	23	
	(E)	kPa	min	10	9	10	15	18	
	Sound power level	(E)	dB(A)	max	46	44	52	58	62
		(E)	dB(A)	med	39	41	44	49	59
		(E)	dB(A)	min	33	34	34	39	53
Sound pressure level		dB(A)	max	37	35	43	49	53	
		dB(A)	med	30	32	35	40	50	
		dB(A)	min	24	25	25	30	44	
	Air flow		m³/h	max	367	398	550	660	760
			m³/h	med	295	355	398	468	660
			m³/h	min	224	269	269	328	550

ASYNCHRONOUS MOTOR (LIGHT 61-65 NC/RC)

Absorbed power	W	max	48	43	63	75	89
Absorbed current	A	max	0,22	0,19	0,28	0,33	0,39

EC BRUSHLESS MOTOR (LIGHT-ECM 61-65 NC/RC)

 Absorbed power	W	max	12	11,2	25,5	40	58
Absorbed current	A	max	0,11	0,11	0,22	0,33	0,47

ELECTRIC HEATER (LIGHT 61-65 NC-E/RC-E)

 Electric heater	W	-	1500	1500	2500	2500	2500
Power supply	V	-	230	230	230	230	230

- **Standard unit with free outlet:** external static pressure = 0 Pa
- **Sound power level:** ISO 23741
- **Sound pressure level:** 8,6 dB(A) lower that the sound power level for a room of 90 m³ with a reverberation time of 0,5 sec.
- **Supported power supply:** ~230V±10% / 1ph / 50Hz



COOLING
Inlet water temp.: 7°C
Outlet water temp.: 12°C
Inlet air temp.: 27°C d.b. - 19°C w.b.



HEATING
Air temp.: 20°C
Inlet water temp.: 50°C

(E)



LIGHT / LIGHT-ECM			81	82	83	83C	84	84C
-------------------	--	--	----	----	----	-----	----	-----

4-PIPE SYSTEM

	Total cooling capacity	(E)	W	max	2350	2750	3400	3890	3900	4470
		(E)	W	med	1940	2410	2550	3000	3100	3460
		(E)	W	min	1630	1890	1910	2000	2400	2660
	Sensible cooling capacity	(E)	W	max	1920	2020	2610	2920	3050	3420
		(E)	W	med	1540	1750	1910	2200	2360	2570
		(E)	W	min	1250	1370	1390	1430	1780	1930
	Water flow		l/h	max	405	473	585	670	671	769
			l/h	med	334	415	439	516	534	596
			l/h	min	281	326	329	344	413	458
Water pressure drop	(E)	kPa	max	18	14	17	22	21	28	
	(E)	kPa	med	15	12	14	19	17	22	
	(E)	kPa	min	10	10	10	15	12	17	
	Heating capacity	(E)	W	max	3050	3500	4450	3300	5000	3710
		(E)	W	med	2600	3050	3500	2670	4000	2980
		(E)	W	min	2010	2450	2450	1910	3150	2390
	Water pressure drop	(E)	kPa	max	15	15	18	23	22	27
		(E)	kPa	med	14	12	15	19	19	24
		(E)	kPa	min	11	9	9	14	12	17
	Sound power level	(E)	dB(A)	max	46	44	52	52	58	58
		(E)	dB(A)	med	39	41	44	44	49	49
		(E)	dB(A)	min	33	34	34	34	39	39
	Sound pressure level		dB(A)	max	37	35	43	43	49	49
			dB(A)	med	30	32	35	35	40	40
			dB(A)	min	24	25	25	25	30	30
	Air flow		m³/h	max	367	398	550	550	660	660
			m³/h	med	295	355	398	398	468	468
			m³/h	min	224	269	269	269	328	328

ASYNCHRONOUS MOTOR (LIGHT 81-84 NC/RC)

Absorbed power	W	max	48	43	63	63	75	75
Absorbed current	A	max	0,22	0,19	0,28	0,28	0,33	0,33

EC BRUSHLESS MOTOR (LIGHT-ECM 81-84 NC/RC)

	Absorbed power	W	max	12	11,2	25,5	25,5	40	40
	Absorbed current	A	max	0,11	0,11	0,22	0,22	0,33	0,33

- **Standard unit with free outlet:** external static pressure = 0 Pa
- **Sound power level:** ISO 23741
- **Sound pressure level:** 8,6 dB(A) lower than the sound power level for a room of 90 m³ with a reverberation time of 0,5 sec.
- **Supported power supply:** ~230V±10% / 1ph / 50Hz



COOLING

Inlet water temp.: 7 °C
Outlet water temp.: 12 °C
Inlet air temp.: 27 °C d.b. - 19 °C w.b.



HEATING

Air temp.: 20 °C
Inlet water temp.: 70/60 °C

(E)





**A GROUP TAKES PART TO THE EUROVENT PROGRAM
OF FAN COIL PERFORMANCE CERTIFICATION
IN ORDER TO PROVIDE ITS CUSTOMERS THE RELIABILITY
AND ACCURACY OF PERFORMANCES.**

