

KLR Rotating Drum Screen

1. Operational Principle

KLR Rotating Drum Screen uses the outside-in flow method. The wastewater enters into the water tank through the water inlet and the purified water flows into cylinder through the grating net gap. The discharge is at the bottom of the cylinder and the grating net is cleaned at the same time. Impurities (which are bigger than the net gap) are blocked by the grating net and are attached to the net cylinder surface. Impurities are taken to the other end by rotating net cylinder, lastly unloading, and then the filtered wastewater is discharged through the outlet. Grating net cylinder is driven through AC variable speed motor.



2. Structure Features and Applications

This machine is suitable for removing minor non-viscous fiber organic matter in wastewater. Rotary net cylinder uses trapezoidal cross-section stainless steel bar to weld together. The advantages are compact structure, small occupied space, reliable and stable operation, easy to install.

3. Main Technical Parameters

Model	Grating Gap	0.5	0.75	1.0	1.5	2.5	Diameter (mm)	Length (mm)	Power (kW)
		Processing Capacity (m³/h)							
KLR-350	15	20	25	32	42	350	600	0.25	
KLR-610	60	81	100	130	170	610	610	0.55	
KLR-612	120	162	200	260	340	610	1220	0.55	
KLR-613	180	243	306	397	520	610	1830	0.75	
KLR-802	315	436	535	695	912	800	1830	1.1	

4. Outline Dimension Table

Model	Inlet Pipe	Outlet Pipe	Cleaning Pipe	A	C	D	E	F	G	H	K	L	S	U
KLS-350	DN100	DN150	DN15	1160	600	950	1470	1080	700	1055	985	1140	676	550
KLS-610	DN150	DN200	DN15	1250	610	1550	1600	980	1175	940	841	1091	806	995
KLS-612	DN200	DN250	DN20	1835	1220	1550	1300	680	1179	604	541	791	1416	995
KLS-613	DN250	DN300	DN25	2445	1830	1550	1600	980	1175	940	841	1091	806	995
KLS-802	DN250	DN300	DN25	2510	1830	1830	2280	1545	1240	1450	1388	1670	2026	1050

5. Equipment Outline and Schematic Diagram

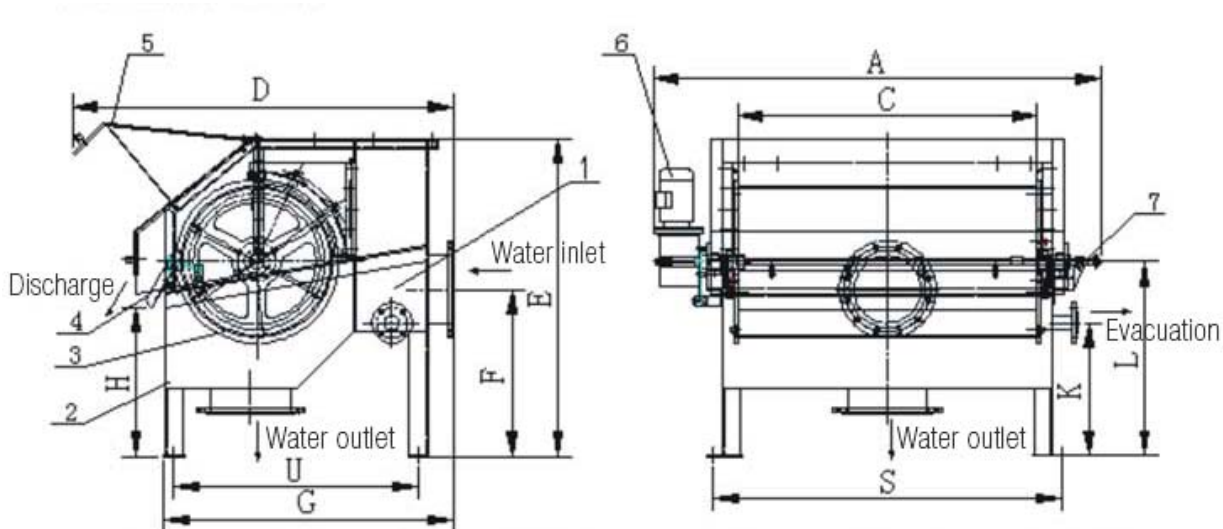

1. Storage tank 2. Frame 3. Drum 4. Slag Plate 5. Inspection Door 6. Gear Motor 7. Backwash water inlet