



**M. R. ENGINEERS**  
offers two configurations of impactors

**The MIM (Impact Mill) Series**

The MRE - MIM series of Impactors are designed for secondary or tertiary crushing of highly abrasive materials and recycling materials. Highly abrasive materials include sandstone, gravel, granite, basalt, glass, refractory rejects, cement clinker and others. Recycling materials include asphalt, concrete, building rubble, bricks and others.

The Impact Mill is widely used in refractory industry as secondary crusher. It is suitable for all kinds of refractory materials with the output sizes in desired gradation.

**MCI (Coal Impactor) Series**

MCI series are designed for medium low silica materials. Medium-low silica materials include limestone, dolomite, bauxite, shale, gypsum, coal and others.

**BENEFITS**

- Versatile selection of horizontal shaft impactors to satisfy most applications
- Wide choice of impact plate and liners
- Easy replacements of wear and spare parts
- Many options to increase crusher efficiency
- One-year warranty
- Continuing service commitment
- Global distribution
- Rapid delivery
- Superior quality
- Advanced materials & processes
- Improved service life of critical components

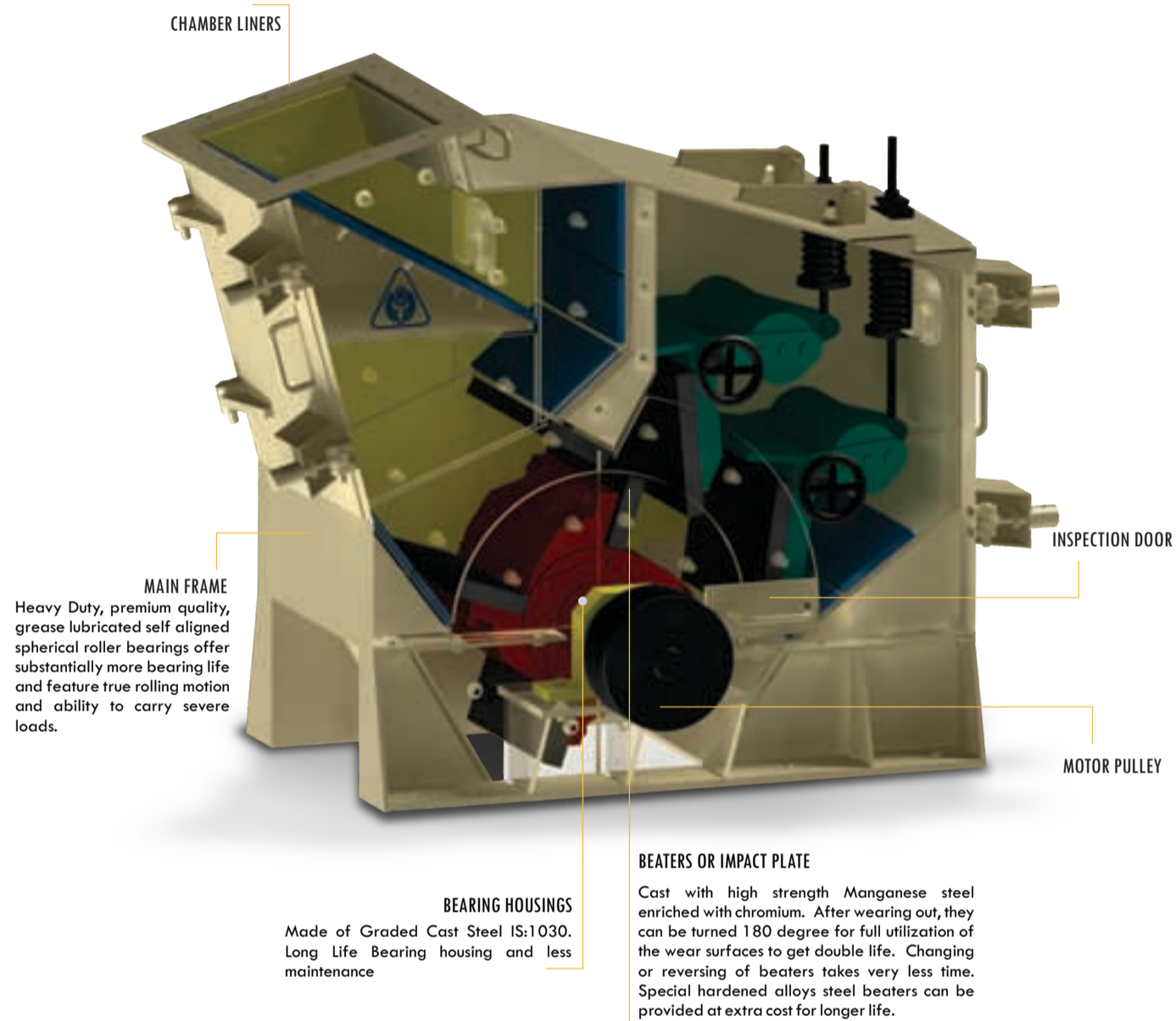

**ROTOR ASSEMBLY (D)**  
Massive, Extra Heavy Duty Rotor are Mild steel Fabricated, welded by sophisticated welding techniques and precision machined for greatest strength. The heart of the impactor is its rotor, which is fitted with two, four or six beater plates according to the particular duty. In wider models, two or three beater plates are placed side by side in a row so that each bar is light enough to be handled with ease during maintenance. The rotor after mounting on the shaft is perfectly balanced, which accounts for the low noise level and long life of bearings.

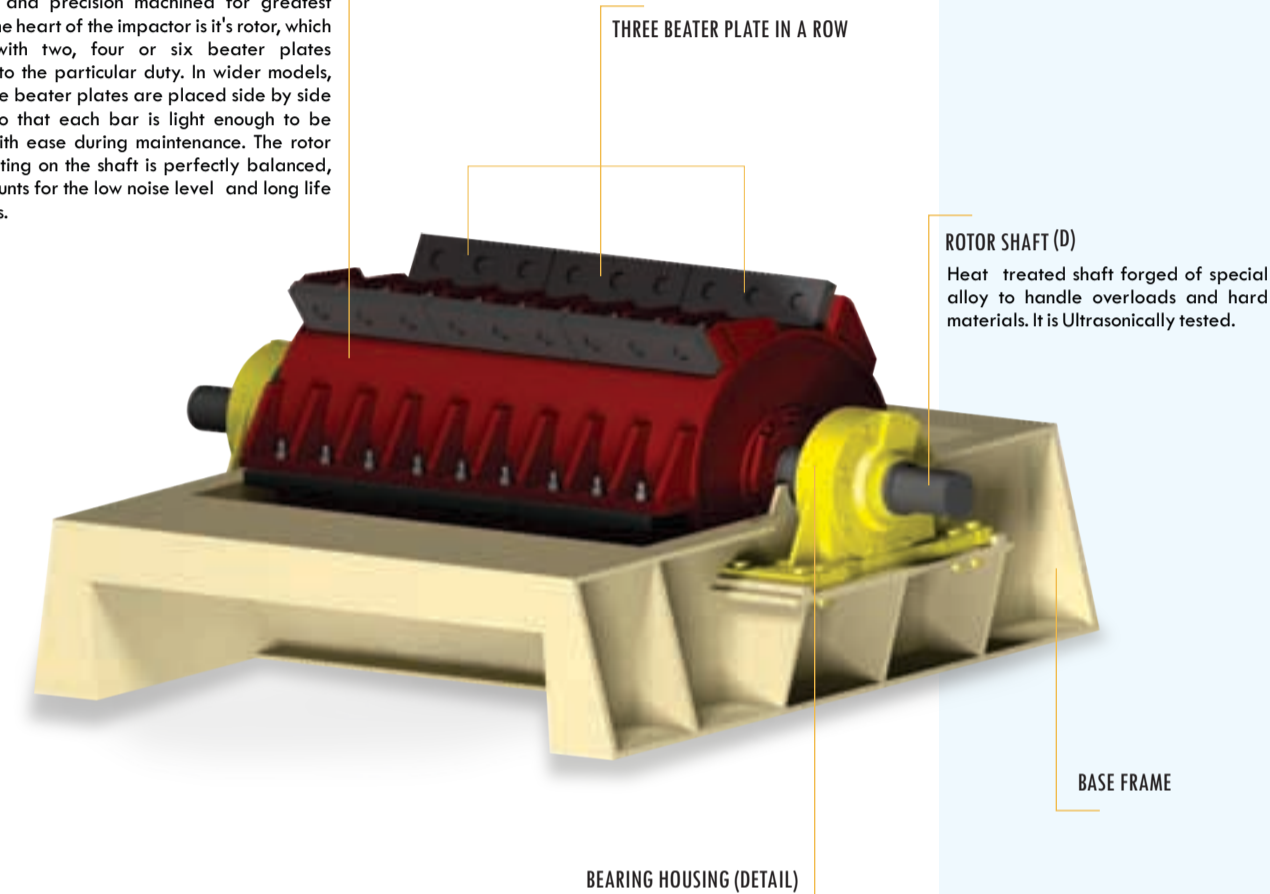

**FEATURES**

- Very High Reduction Ratio
- High and Constant Capacity
- Quick and Easy Installation
- Absorption of Crushing forces by Heavy Springs
- Large Access Doors on Front, Back and Top of Crusher.

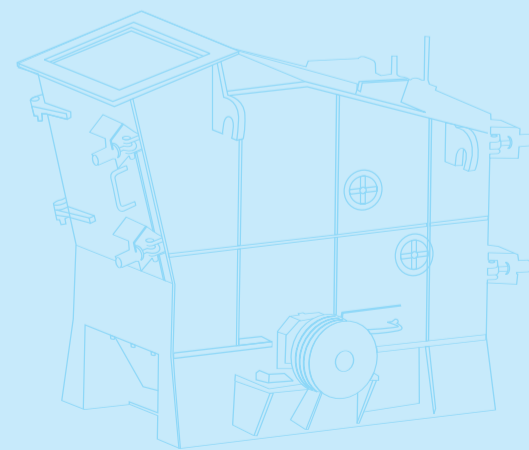

**WORKING PRINCIPLE**

The incoming feed material first strikes the impact plates on the rotor and is then impacted on the primary breaker plates, it is then impacted on the secondary breaker plates where the final sizing of the finished product is acquired by the setting of gap of the plates. As the material breaks due to Impact & due to input of more kinetic energy, material breaks equally in all directions giving cubical product. When any non-crushable object is introduced to the machine, the impact frame will fall back, hence the stuff fall from the machine. This device can prevent machine from damages.

**STANDARD DESIGN FEATURES**

- Heavy duty fabricated plate steel construction ribbed for extra strength
- Fabricated disc rotor assembly
- Feed chute sides and crushing chamber are lined with highly abrasion resistant, alloy steel liners





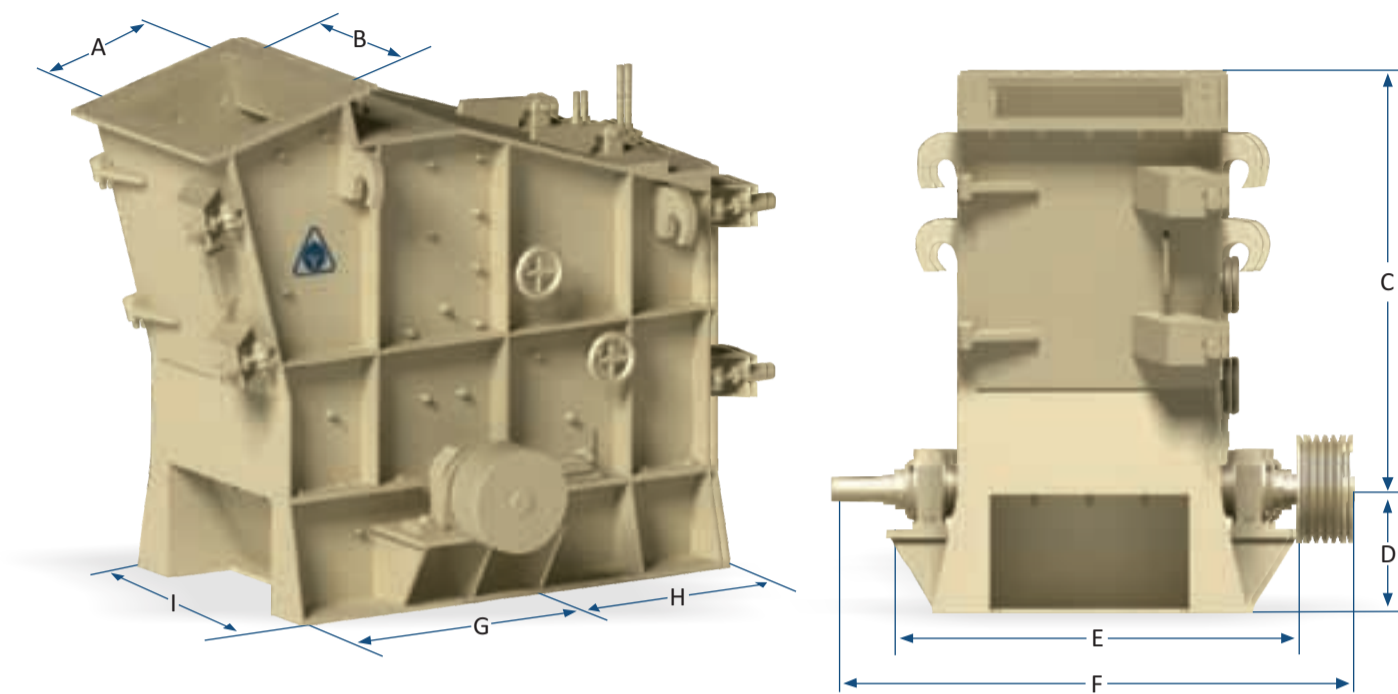

**OVER-ALL DIMENSION OF IMPACTOR**

	A	B	C	D	E	F	G	H	I	ROTOR(LXØ)
MIM 500	400	500	1075	275	1120	1425	560	840	865	500 X 600
MIM 750	400	750	1100	385	1370	1680	610	900	1080	750 X 830
MIM 1000	450	1000	1125	410	1675	2000	680	975	1320	1000 X 965
MCI 1000	450	1000	1125	410	1675	2000	680	975	1320	1000 X 965
MCI 1500	480	1500	1200	520	2175	2600	800	1100	1820	1480 X 1005

**TECHNICAL DATA**

MACHINE MODEL	FEED SIZE (mm)	MACHINE SPEED (rpm)	MOTOR HP/rpm	MACHINE PULLEY (P.C.D)	CAPACITY ton/hr	PRODUCT SIZE (mm)	OVERALL DIMENSION (L X B X H) (mm)	No. OF BEATER PLATE
MIM 500	10 - 75	450 - 1000	25 / 1440	300	5 - 25	0 - 20	1400 X 1425 X 1350	4
MIM 750	10 - 75	450 - 1000	40 / 1440	450	7 - 35	0 - 20	1450 X 1650 X 1465	8
MIM 1000	10 - 100	450 - 1000	60 / 1440	660	10 - 50	0 - 30	1655 X 2000 X 1535	8
MCI 1000	20 - 100	300 - 550	50 / 1440	660	20 - 70	0 - 40	1655 X 2000 X 1535	12
MCI 1500	20 - 150	300 - 550	60 / 1440	810	30 - 100	0 - 50	1800 X 2600 X 1720	18

- ▶ Do not use these dimensions for manufacturing, installation and foundation work.
- ▶ Capacities are approximate & vary by 25 % depending on type of rock gradation and method of feeding.
- ▶ The Design of MCI and MIM Series is subject to change / alteration / modification without any notice.

**TURNKEY PROJECTS**

M. R. Engg. have the infrastructure to design, detail, fabricate, manufacture, erect and commission full plants of any description or size. M. R. engg. has installed plants throughout India, and has serviced clients including TRL, NALCO, BHUSAN, AROMA, Bhaskar and Scan Steels.

**MISCELLANEOUS PARTS**

M. R. Enggs. offer a full range of spare parts and optional Equipments to suit most applications including: 'V' Belts, Conveyor belts, Electric motor and drive guard.

**PRODUCT SUPPORT SERVICES**

- Providing a fully qualified product support/ service team to meet your requirements.
- Technical support & assistance
- On site repairs
- Preventative maintenance
- Product training

**PRODUCT RANGE**

- Crushing Equipments
  - ▶ Jaw Crusher
  - ▶ Roll Crusher
  - ▶ Impact Crusher
  - ▶ Coal Crusher
- Material Handling Equipments
  - ▶ Bucket Elevator
  - ▶ Belt Conveyors
- Feeding Equipments
  - ▶ Vibro Feeder
  - ▶ Reciprocating Feeder
  - ▶ Grizzly Feeders
- Custom made Designs
- Grinding Equipments
  - ▶ Impact Mill
  - ▶ Circular
  - ▶ Hexagonal Ball Mill
- Screening Equipments
  - ▶ Vibrating Screen
  - ▶ Rotary Screen
- Refractory Equipments
  - ▶ Counter Current Mixer
  - ▶ Counter Current Intensive Mixer
  - ▶ Friction Screw Press
  - ▶ Hydraulic Press

**M. R. ENGINEERS**  
**HORIZONTAL SHAFT IMPACTOR**  
 MIM and MCI SERIES



M. R. ENGINEERS

**M. R. ENGINEERS PVT. LTD.**  
 Jampali By Pass Road, Garvana, At - Rajgangpur,  
 Dist- Sundergarh - 770017, Odisha  
 Tel: +91 9337 140761 / +91 6624 220761,  
 Fax: +91 6624 222761  
 business@mrudyog.com www.mrudyog.com



Engineering Future  
 AN ISO 9001: 2008 COMPANY



M. R. ENGINEERS