

OPERATING AND INSTALLATION INSTRUCTIONS FOR POSITION TRANSMITTER MODEL SG-PTx

The SG Position Transmitter is a two wire electronic instrument that converts resistance input into current output. It measures and transmits linear as well as angular displacement of various types of valves and other control devices. The change in resistance derived from the field mounted potentiometer is given to the electronic circuit of this instrument. Also a supply of 24 Volts DC is connected externally to the terminals in series with ammeter as shown in the wiring diagram.

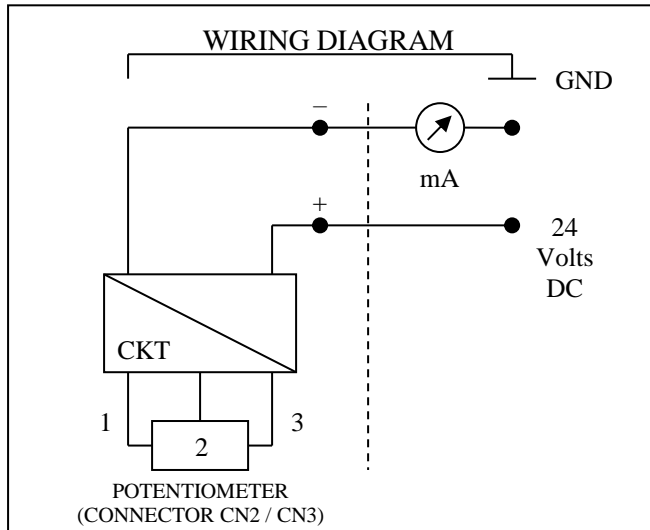

The instrument can be coupled to any reciprocating part to get a direct output of 4-20 mA. The lever of the instrument is fixed to a gear that drives the pinion fixed on the potentiometer shaft. Thus the potentiometer shaft rotates in proportion with the lever which is further connected to the reciprocating part of valve or any other control device using appropriate linkages.

The **Zero** and **Span** settings are provided by which accurate output values of 4 and 20 mA can be achieved. As a standard practice the 4-20 mA output signal from the transmitter is so adjusted that 4 mA coincides with the down most position of the lever and 20 mA with the upper most position of the lever. However, if the output of 4-20 mA is required in reverse way that is 4 mA at the upper most position and 20 mA at the down most position of the lever then **interchange connector CN2 to CN3 or vice versa**.

SG Position Transmitter senses the position of the reciprocating part very precisely with respect to input signal to the final control element and ensures a reliable and accurate operation of position feedback.

INSTRUMENT MOUNTING: The instrument should normally be mounted upright, that is, with the cable gland port at the bottom. If installed in any other orientation, operation is possible but dust and water may enter into chamber through cable gland causing instrument to malfunction or even becoming dead thus making warranty void. The instrument is protected against environmental effects, that is, splashing water and dust ingress in normal working operation.

SG Position Transmitter is field reversible and mounting can be done as per requirement. Mounting holes are provided on both the sides to suit client's requirement. Back lever too can be rotated from the existing position by simply un-screwing the 2 holding screws.

WARNING: TO CHANGE THE ORIENTATION OF THE BACKLEVER, BACKLEVER SHOULD BE REMOVED FIRST BY UNSCREWING THE TWO HOLDING SCREWS. AFTER CHANGING THE ORIENTATION OF THE BACKLEVER REFIX THE BACKLEVER HOLDING SCREWS BACK TO PLACE SECURELY. ALSO MAKE SURE TO CHANGE THE LOCATION OF TWO MECHANICAL STOPPERS PROVIDED. BACKLEVER SHOULD MOVE WITHIN THE MECHANICAL STOPPERS STRICTLY.

NEVER CHANGE THE ORIENTATION OF THE BACKLEVER BY DIRECTLY ROTATING. THIS MAY DAMAGE THE POTENTIOMETER OR POTENTIOMETER PINION GEAR MAY BECOME LOOSE THUS RESULTING IN MALFUNCTIONING OF INSTRUMENT. DOING SO WILL MAKE WARRANTY NULL & VOID.

CALIBRATION AND MAINTENANCE POSITION TRANSMITTER

This instrument is designed for continuous operation without the necessity for routine maintenance and is supplied calibrated. However, re-calibration is necessary after mounting to suit individual controllers because instrument is supplied calibrated for full range ie; 0-60/90 degrees as per the model.

Please Note: This instrument can be calibrated anywhere between 0-30/40 degrees to 0-60/90 degrees as per the model.

The calibration procedure is as follows:

1. With the reciprocating part at mid stroke (50%) adjust the transmitter lever to approximate perpendicular position with reference to the reciprocating part.
2. Decrease the control signal to minimum required level. Ensure that position transmitter lever moves at least by 15/20 degrees minimum on one side (maximum allowable movement is 30/45 degrees on one side as per the model).
3. Adjust potentiometer and bring it to zero. Check the rotation direction of the big gear. If on increasing the signal big gear moves in clockwise direction, the potentiometer is to be rotated in counter clockwise to set zero. This is the sub-zero setting of transmitter.

IMPORTANT: AT SUB-ZERO POSITION ROTATE POTENTIOMETER BY ABOUT 3 TEETH TO ENSURE POTENTIOMETERS SAFETY.

4. Once the sub-zero setting is done, adjust the zero adjuster on the electronic card to achieve 4 mA output signal. Output signal increases as zero adjustment is turned clockwise.
5. Now increase the control signal to maximum required level. Adjust the span adjuster on the electronic card to achieve 20 mA output signal. Output signal increases as span adjustment is turned clockwise.
6. Repeat zero and span adjustment until no further adjustment is needed.

For reversing the action of signal output, interchange the Connector CN2 (FORWARD) and connect CN3 (REVERSE) and carry out the procedure as above, but note that 4 mA will now be maximum signal and 20 mA will be at the lowest value of signal.

LIMIT SWITCH

SG Position Transmitter also comes with built-in Limit Switch (optional) to enhance the performance of valve automation system. The standard model comes with 1 NO + 1 NC contacts, however to meet your required service conditions 2 NO + 2 NC contacts can also be provided. Two cams are provided for actuating limit switch for Close & Open positions respectively. Limit Switches and cams are labeled LS1 & LS2 where LS1 pertains for CLOSE (4 mA) position and LS2 pertains for OPEN (20 mA) position. Loosen the grub screw using 2 mm Allen key and at close position rotate the LS1 cam slowly till LS1 Limit Switch actuates. At this position tighten the grub screw to secure the same at the required position. Now open the valve completely and repeat the same procedure with LS2 cam to actuate LS2 Limit Switch. Your Position Transmitter with built-in Limit Switch is now ready for use.

AFTER SALES SERVICE

Internal components are delicate and care must be taken while handling. Repairs and calibration should be done by skilled instrument technicians.

If servicing is required, please contact factory.

Manufactured by: **SG Electronics**

Haware Ceturion Complex, Unit No. S-12/90, 2nd Floor
Plot No. 88 to 91, Sector 19A, Nerul-Seawoods
Navi Mumbai – 400706, Maharashtra (INDIA)

☎ +91-22-65652058 ● +91-7738987671

Email: sales.sgprocess@outlook.com

Website: www.sgprocess.com / www.sgelectronics.org